



# WATER

Intelligent eco solutions



Roto Group is an international company specialized in the production of plastic products. The roots of the family-run business go back to 1949. ROTO employs more than 550 people in 8 factories located in different European countries. Roto generated revenues of €82 million in 2021, selling products in 65 countries around the world.

Roto is European leading rotomoulding company, producing more than 4,000 different products. The company's development is ensured by continuous innovation, new technologies and materials that ROTO develops together with scientific institutes, universities and other companies.

The Roto-branded product groups are divided into four segments: products for agriculture, garden, sport and ecology. The use of composites and biodegradable and recycled polymers enables the production of the most complex products on the market.



**EY**  
EY world  
family award

Roto also manufactures a wide range of components products for various industries such as automotive, marine, construction and agricultural machinery, aquaculture and logistics. Added value innovative design, the use of intelligent polymers and composites, upgrade of products with accessories.



Cernelavci, Slovenia



Puconci, Slovenia



Hrusica, Slovenia



Vinica, Macedonia

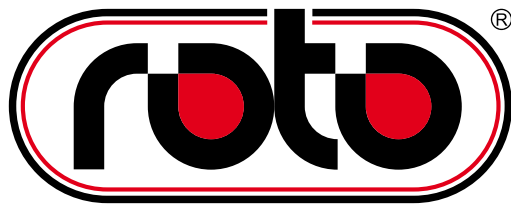

# Distribution across Europe

ALWAYS NEAR TO YOUR CONSTRUCTION SITE

## Slovenia

tel: +386 2 52 52 152  
eco@roto.si

## Austria

tel: +43 664 21 03 495  
austria@roto-group.eu

## Italy

tel: +39 328 225 05 17  
italy@roto.si

## France

tel: +33 6 35 41 80 31  
france@roto-group.eu

## England

tel: +44 (0) 7880 603010  
sales@roto-group.co.uk

## Germany

tel: +49 (0) 151 67188855  
info@rotoeco.de

## Hungary

tel: +36 30 500 9003  
hungary@roto-group.eu

## Croatia

tel: +385 91 14 395 12  
info@roto-grad.t-com.hr

tel: +385 98 240 332  
info@okiroto.hr

## Serbia

tel: +381 66 668 00 43  
alibunar@roto.si

## Macedonia

tel: +389 3 33 63 516  
zoran@roto.mk

## Bosnia

tel: +387 33 780 096  
prodaja@roto.ba

## Bulgaria

tel: +359 88 676 67 97  
bulgaria@roto-group.eu

## Slovakia

tel: +421 905 258 292  
slovakia@roto-group.eu

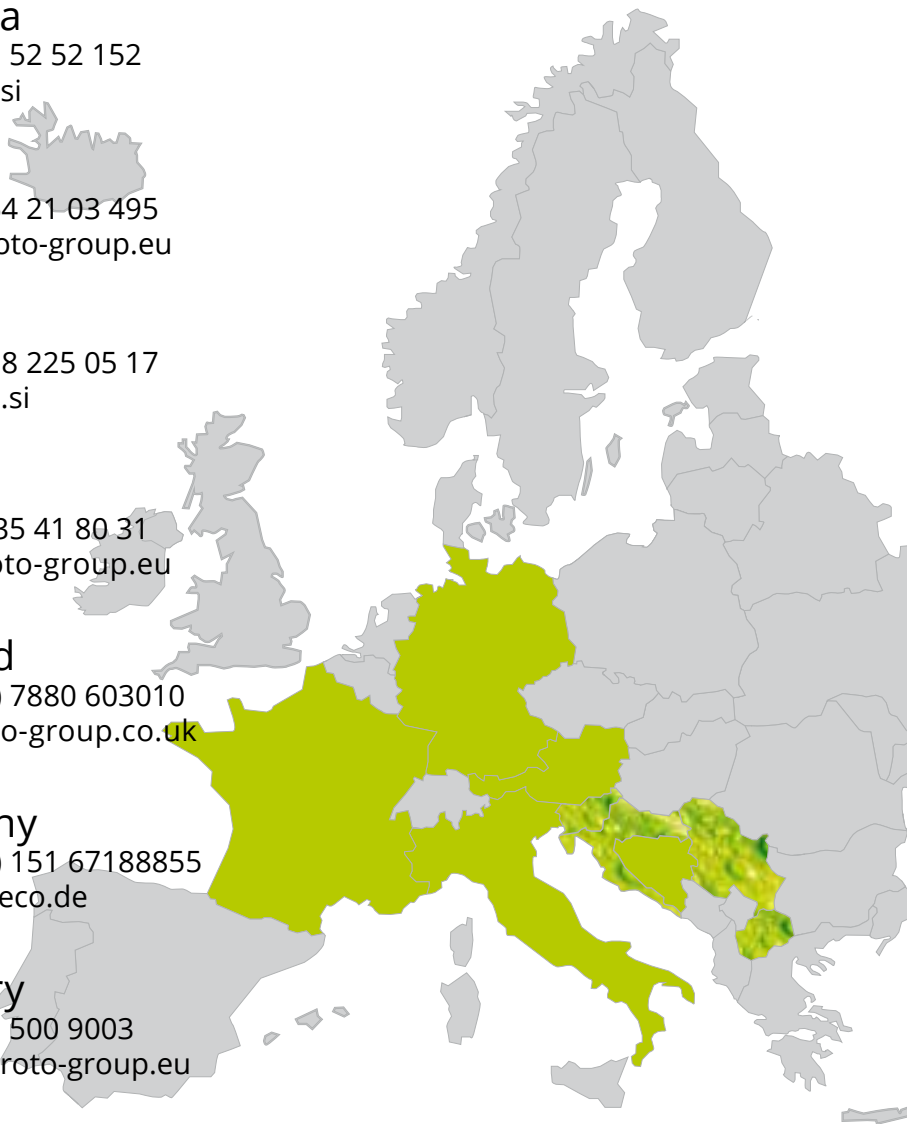

Roto companies



Production



Distributors



Pregrada, Croatia



Alibunar, Serbia



Ivanic Grad, Croatia



Friesoythe, Germany



**WATER**

water tanks, waste water treatment plants, oil separators, septic tanks, shafts



**AGRI**

winebarrels, barrels for brandy, vinegar, sauerkraut containers, silo, wheelbarrows



**GARDEN**

planters and flower pots, garden figures, garden furniture, ponds, composters

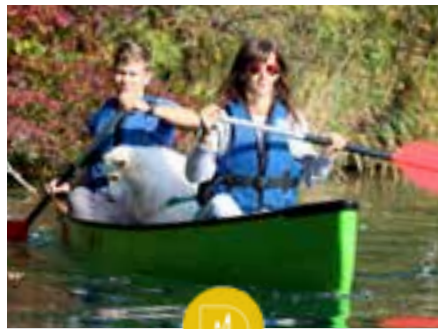

**SPORT**

kayaks, canoes, boats, karting barriers



**LOGISTICS**

containers, pallets, road barriers, karting equipment



**INDUSTRY**

agricultural machinery, caravanning, nautic, moto



RoBox 35

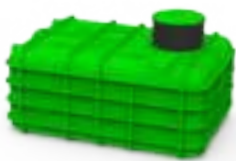

RoTerra 22



RoCko 28



RoQuadro 36



Water tanks

EcoBox 38



RoClean 40



RoEco 50



EcoBlue 52



Waste water treatment plants

EcoFloat 56



RoSeptic 64



RoSeptic 65



RoCube 62



Septic tanks

RoGra 67



RoFett 69



RoGre 70



RoMast 71



Grease separators

RoSep 72



RoPetrol 78



RoOil 79



RoOil 80



Oil separators

Drainage shafts 82



Water calming shafts 88



Road gullies 89



Water meter 90



Shafts

RoPump 94



GRP pumping stations 99



Accessories 100



Spare parts 108



Pumping stations



ROTO technical team provides you with comprehensive support from the start of the project to the management of the facility. ROTO's smart water management solutions include a full range of services, from project development, design and engineering to procurement of system components and project management through technical operations and maintenance. We can also prepare all the necessary project documentation for you.

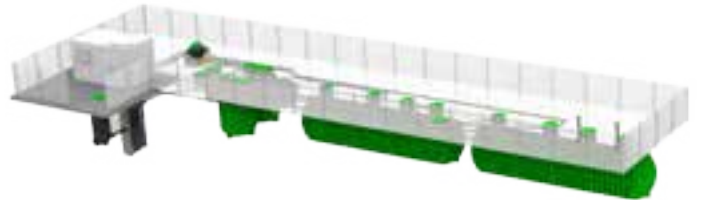

Check the existing input data



Visit the construction site

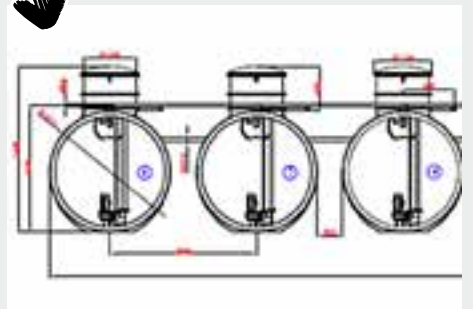

Searching for the optimal technical solutions

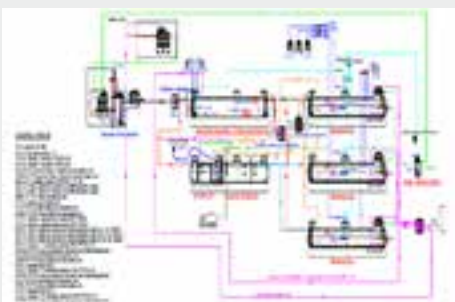

Project management, obtaining the required building approvals



Installation of products and hand over the required technical documentation



Operation and maintenance

## Products Selection

Contact a ROTO distributor for assistance with selection and sizing. Our friendly and knowledgeable experts are here to help. With product configurator you can easily select, design, configure, price and quote appropriate product or system solutions for your industrial, municipal or commercial project and applications through ROTO ECO calculators. Drawings and technical description are available to designers and architects on professional software libraries like BIM.



## Special product for your project

The ROTO water products could be customised to your specifications and needs. They can be delivered, installed and supported by a ROTO technical team that knows the importance of being responsive. We can also help you to upgrade the existing products and solution or adapt it according to your needs.



## Support for any situation

How do I contact ROTO customer service? As an installer, you have the choice of ordering ROTO customer service from your specialist wholesaler, Roto country distributor or contacting us directly. As a private customer, we ask that you refer to a specialist installation company in your area. Membership to the ROTO technical institute is free and offers access to webinars, technical data about the products and other training resources.

## Install & Operate

Ensure that your system functions at its best from day one. Find how-to guides, videos, FAQs, user manuals, technical documentation and related services to help you with installation and operation of your ROTO products. Discover a range of online engineering, installation and operation tools and up-to-date product design information that can assist you in your work today, and help you work smarter over the long run.



## Spare parts shop

The ROTO online spare parts shop: 24-hour service for accessories and spare parts of our products. Get replacement ROTO parts with easy selection and fast delivery.



## Repair & Maintain

Ensure that your system continues to function at its best. Find how-to guides, videos, FAQs and related services to help you with repair and maintenance of your ROTO products. Look for how to guides here to find quick and easy guidance and support for all phases of your project.

## ROTO Digital Services means less labor and better monitoring

Ensure that your system functions at its best. Our Digital Services consist of several different offerings that can be mixed and matched to best fit your needs, from simple solutions to complex digital setups. From remote online monitoring and diagnostics to on-site service, ROTO is there when and where you need us.



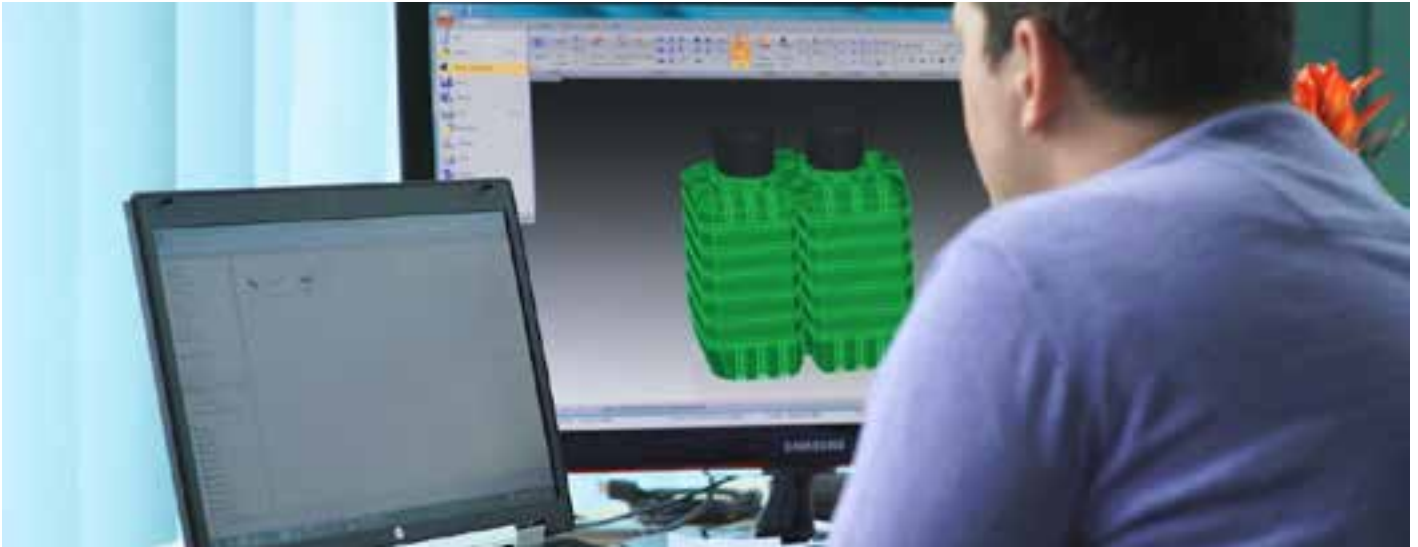

## The New Product Development Department develops three new products per week

ROTO offers complete solutions to its partner companies. From 3D computer-aided product design and simulation, 3D printer prototyping, tooling, production and mass production.

We are an innovative company, always looking for new technologies, ideas and solutions. The R&D centre employs 20 people who develop more than 150 different products a year.

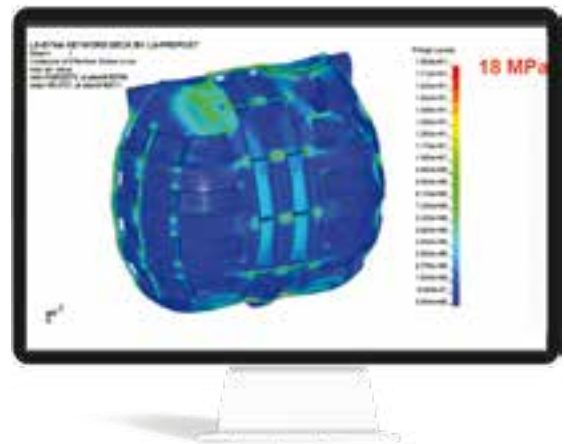

## Product adaptation Customized and individual solutions

- Construction drawings
- Building information modeling
- Technical reports
- Construction site communication
- Adaptation of products in the factory or on construction site according to the project





## Prototypes and tool making

Product development at ROTO starts with gathering input and requirements from our customers. Once the information has been gathered, concepts and solutions are developed that will lead to the desired new product. The work is supported by a design team that will guide you through each phase of the project and present you with the appropriate technical solutions on an ongoing basis.

With the capacity to print prototypes up to 2x1 m, the 3D printer makes the process from idea to solution short and cost-effective. After the design and sample have been approved, the production tools are prepared.



## Production of the largest polyethylene products

The rotational moulding process makes it possible to produce tanks in one piece. ROTO production is equipped with 39 different rotating machines. Among them is a machine for making monolithic tanks up to 25,000 litres.





The ROTO laboratory analyses various waste water parameters such as BPK<sub>5</sub>, BOD<sub>5</sub>, COD, TOC, SS, etc. We also carry out in-house microscopic and microbiological analyses of waste water as well as the performance of oil traps.



## Product performance test

The ROTO simulates the performance and impact of various external factors under different conditions purification efficiency, measuring the durability of materials, the watertightness etc.



Certification of ROTO products is carried out by institutes in different countries





If a deeper burial is required, or if the tanks need to withstand vehicles driving over them, please let us know so that we can provide you with GRP solutions. Underground fibreglass storage tanks are a high-strength and long-lasting storage option used to contain drinking water, non-drinking water, wastewater, and chemicals. Fiberglass tanks are built with a robust outer exterior that holds up to below ground storage, while their interior fiberglass resins are built to match the liquid being stored in the tank. Vertical polyester water tanks with stand are manufactured for safe storage of various chemicals as well as for storage of every kind of water.



## Stainless steel products

We manufacture pipelines and equipment for drinking water and waste water for water storage facilities, pumping stations, decanters for waste water treatment plants, and mixers for waste water treatment plants. We also carry out installation work on drinking water facilities.



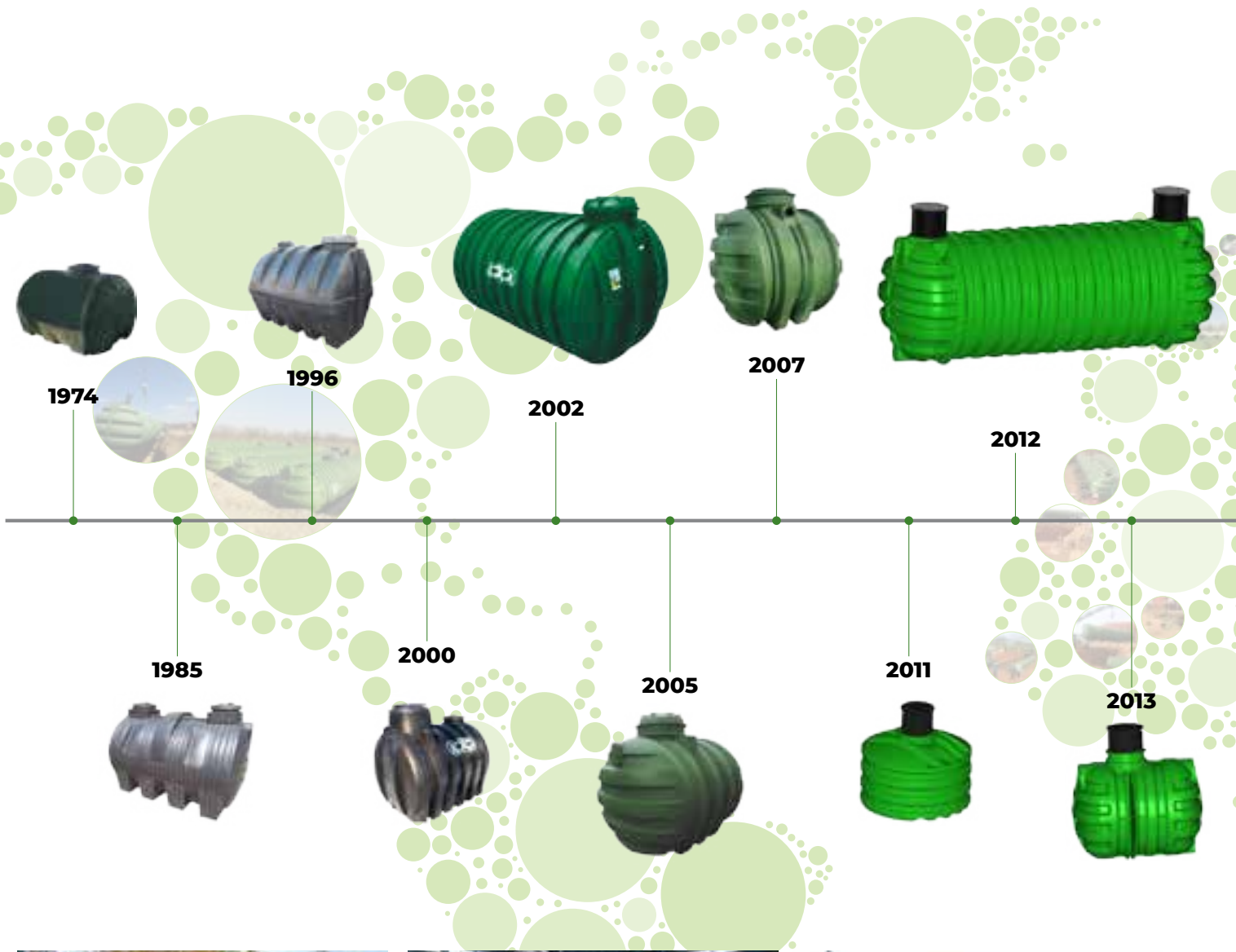

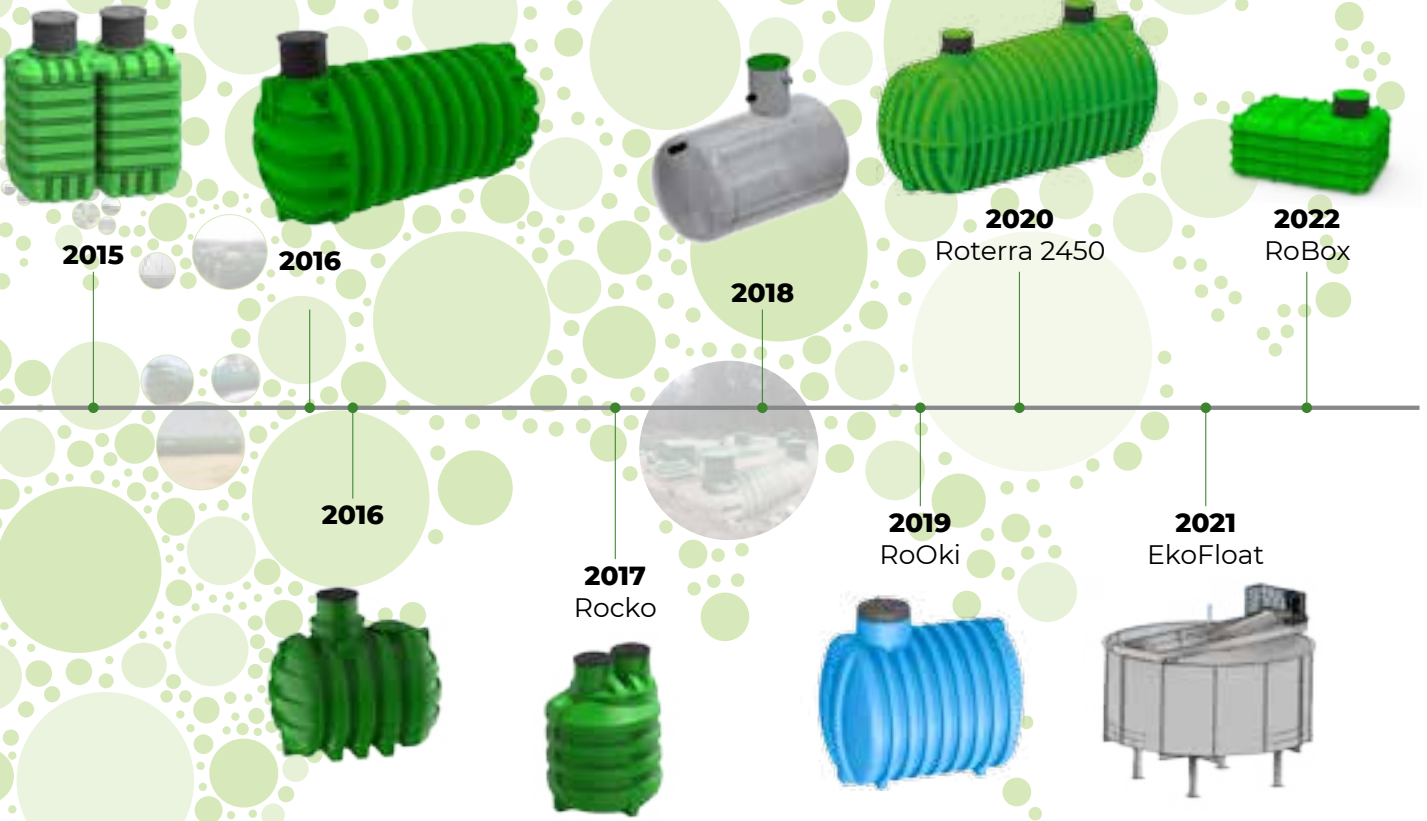

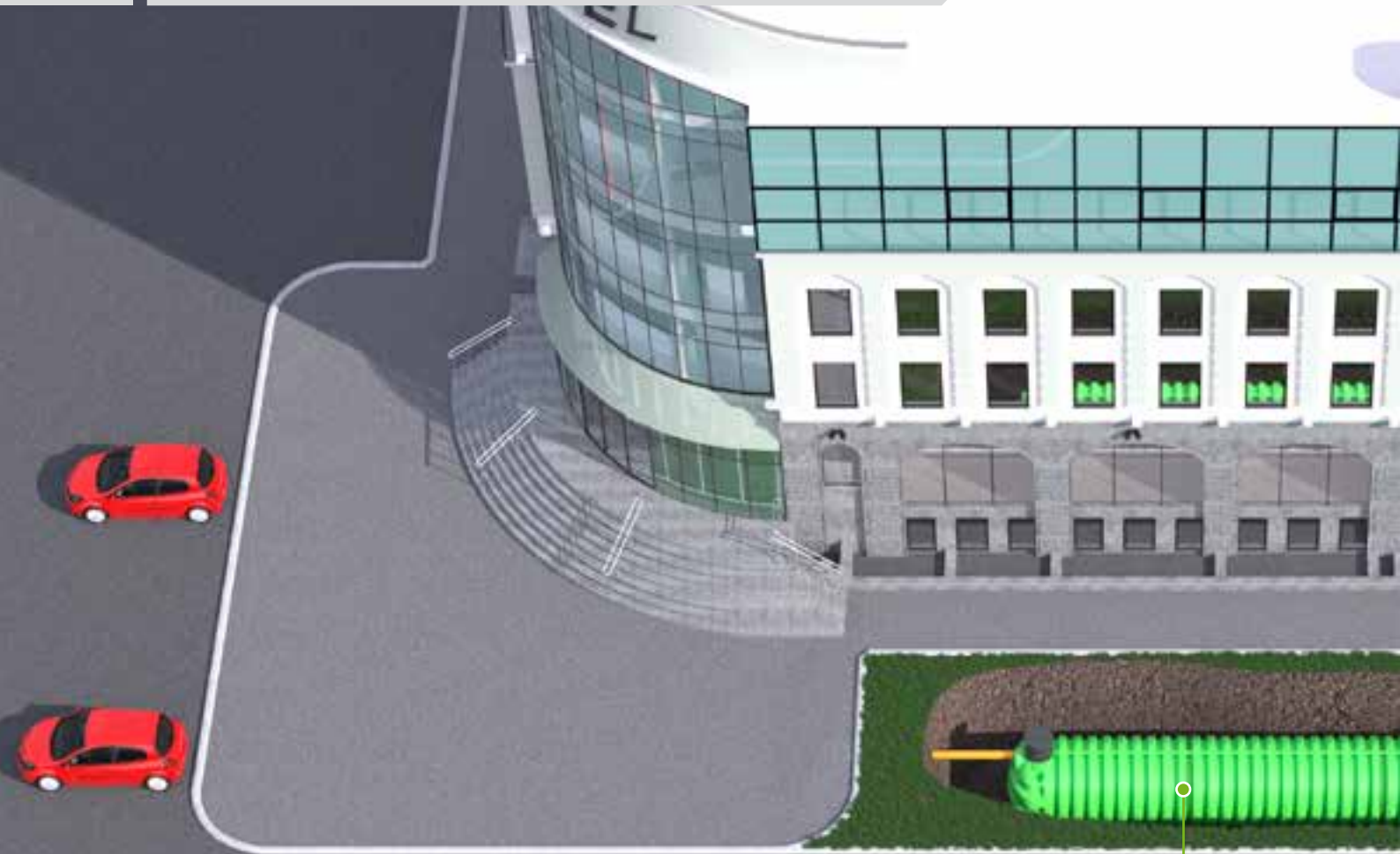

UNDERGROUND RAINWATER TANK

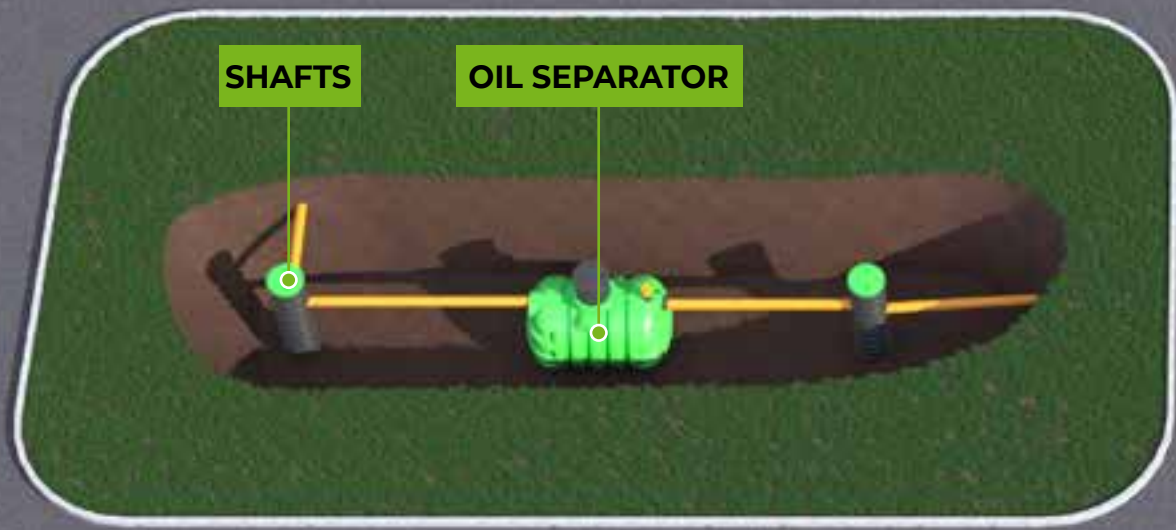

SHAFTS

OIL SEPARATOR



**WATERMETER  
SHAFT**

**GREASE  
SEPARATOR**

**WASTE WATER  
TREATMENT PLANT**

**INFILTRATION  
TUNNEL**

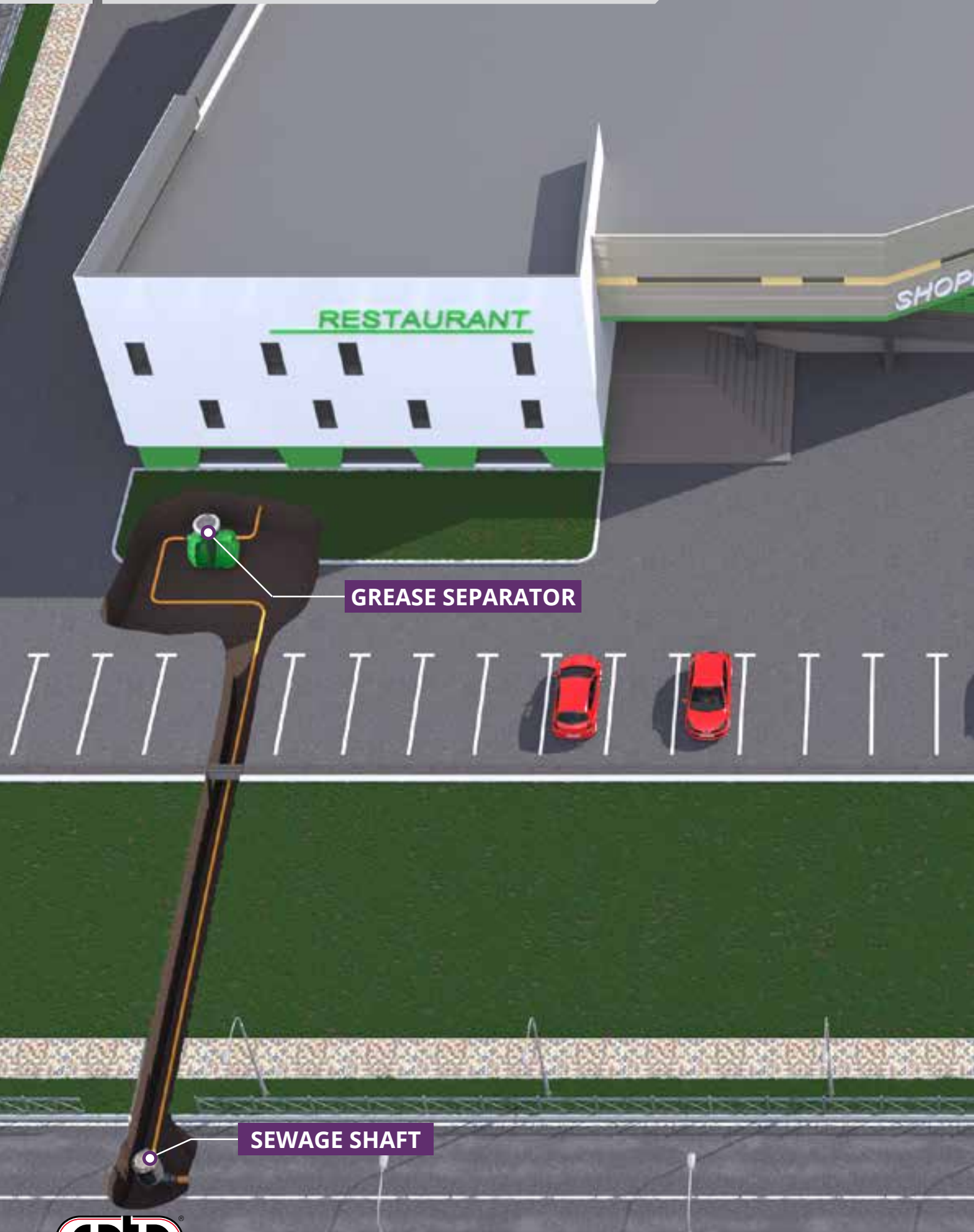

**GREASE SEPARATOR**

**SEWAGE SHAFT**



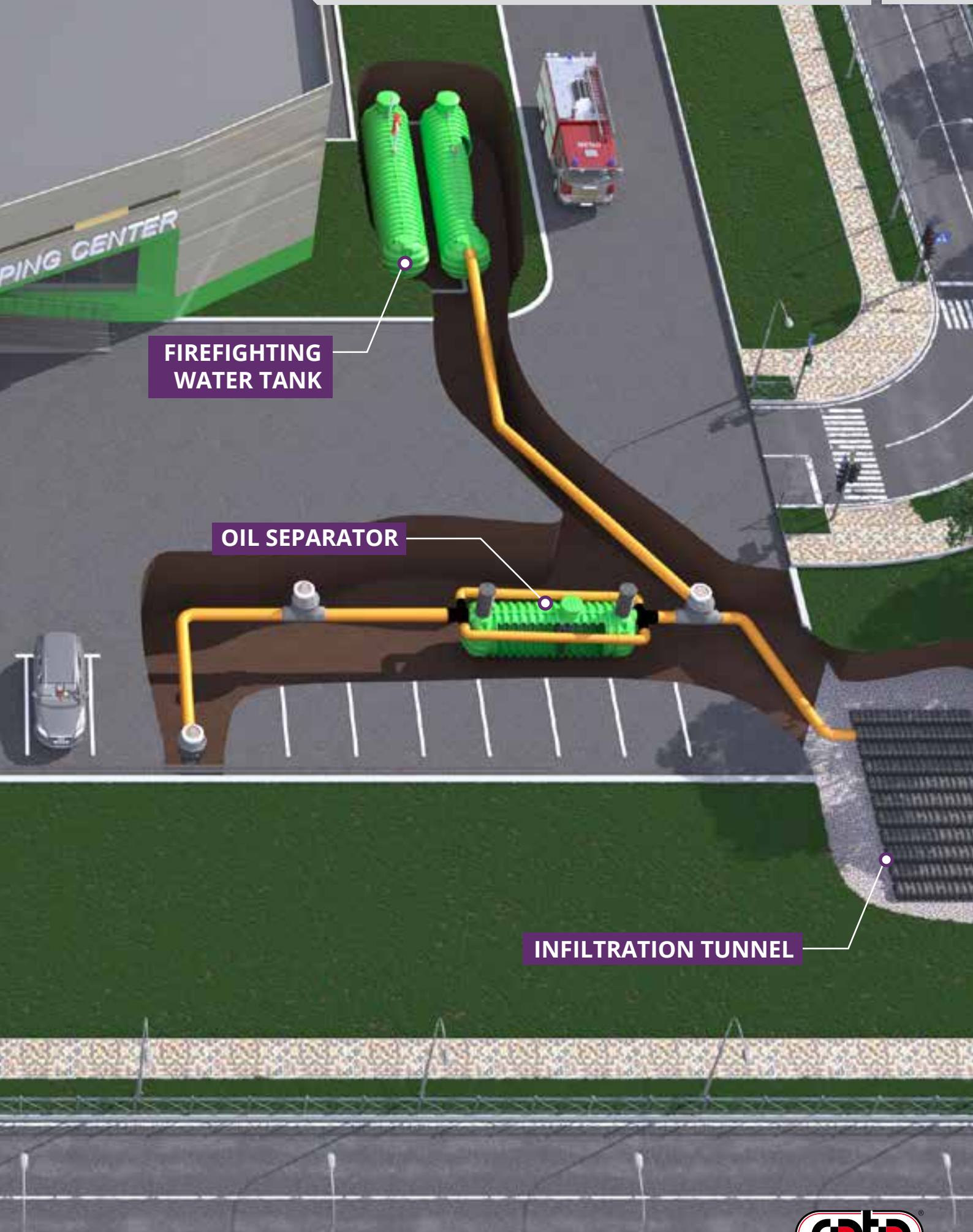

**FIREFIGHTING  
WATER TANK**

**OIL SEPARATOR**

**INFILTRATION TUNNEL**



**GREASE SEPARATOR**

**SHAFT**

**WASTE WATER TREATMENT PLANT**

**ADBLUE TANK**

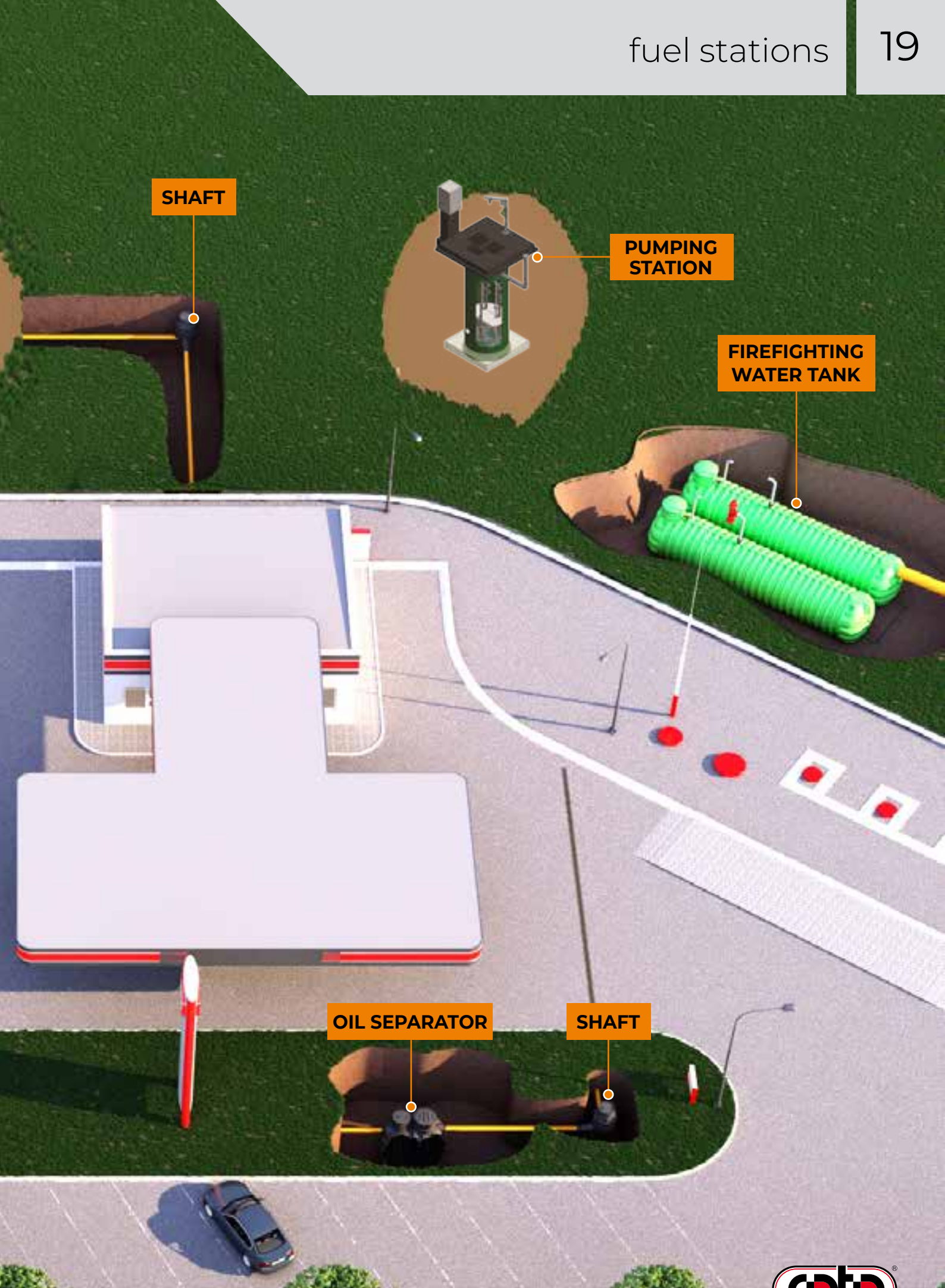

SHAFT

PUMPING STATION

FIREFIGHTING WATER TANK

OIL SEPARATOR

SHAFT

Water tanks

# Roterra professional firefighting water tank systems

ROTO Roterra water tanks are suitable for the preparation of firefighting water systems. The professional system complies with DIN 14230. We offer you standard equipment for universal solutions or custom-made equipment that is made according to the customer project.



**Equipment:**

1. inspection opening DN 1000 or DN 800
2. stainless steel ladder
3. suction pipe up to DN 250 (including anti-vortex plate) - PE or stainless steel
4. connection for fire hose - coupling type A
5. ventilation pipe up to DN 160 (PE or stainless steel)
6. PE inlet / outlet connection



Waste water treatment plants

Septic tanks

Grease separators

Oil separators

Shafts

Pumping stations



**DHL LOGISTICS CENTER**  
2x ROTERRA 50.000 L



**FUEL STATION**  
2x ROTERRA 50.000 L



**WAREHOUSE**  
8x ROTERRA 50.000 L



**FACTORY**  
2x ROTERRA 40.000 L



Water tanks

Waste water treatment plants

Septic tanks

Grease separators

Oil separators

Shafts

Pumping stations

# Roterra

## HINGED COVER

The Roterra tank cover with gasket ensures water tightness. The lid is hinged to the telescopic extension, making it easy to open.

## TELESCOPIC EXTENSION

Telescopic extension installed on the Roterra tank is thread shaped and allows us fast and simple adjustment to the terrain. The dimensions of the extension are DN600x400 mm.

## FLAT SURFACE FOR PIPE CONNECTIONS

## INFLOW



## OUTFLOW



## POSSIBILITY OF CONNECTION

## REINFORCEMENT RIBS

Reinforcing ribs on both sides ensure the stability of the tank and protection in case of high water level.

## Roterra water tank features:



Tank for underground installation



Material: polyethylene



Made in one piece, 100% waterproof



Excellent statics, resistance to earth pressures and external forces



Wall thickness 8 - 14 mm



Possibility to adjust the height of the extension to the requirements of the terrain



The product can be 100% recycled after use

BASIC EQUIPMENT INCLUDES: telescopic extension and lid.



**WATER TANKS**

Design and excellent statics of Roterra tanks allows us fast and simple underground installation.

Polyethylene cover is installed on the telescopic extension which provides 100% watertightness. Its loading capacity is up to 0,2 kN/m<sup>2</sup> in standard PE option or up to 250 kN with solid lid covers and correct installation.

Inflow and outflow can be made on the flat surfaces, which can be prepared according to the customer requirements (for water distribution, PVC or PP pipes from DN50 to DN400).

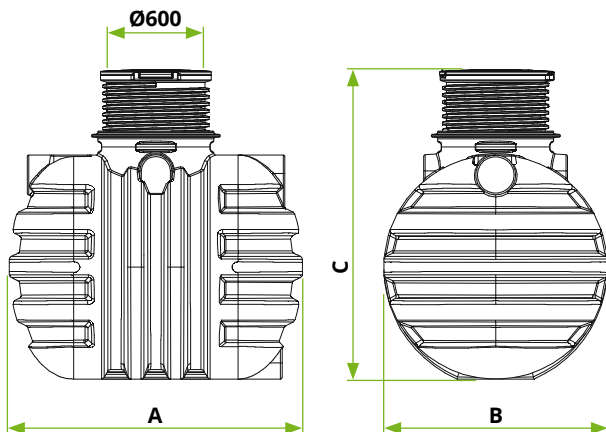
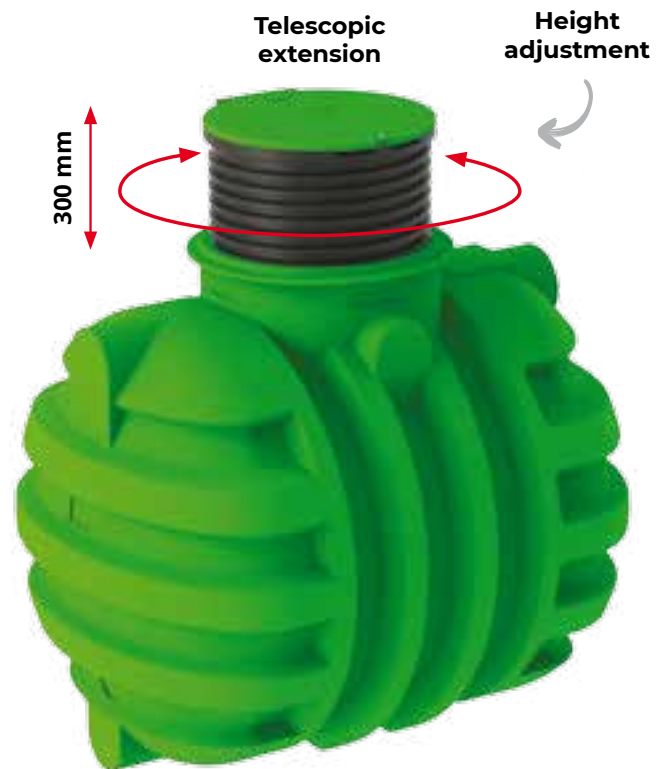

Volume [L]	Code	Dimensions A x B x C [mm]	Cover [mm]	Weight [kg]
2.200	7100067160	1840 x 1400 x 1600-1900	Ø600	100
2.600	7100067180	2150 x 1400 x 1600-1900	Ø600	115
3.000	7100067170	2400 x 1400 x 1600-1900	Ø600	130
3.300	7100069480	2650 x 1400 x 1600-1900	Ø600	145
3.500	7100067120	2080 x 1800 x 2050-2350	Ø600	165
5.000	7100067130	2450 x 1800 x 2050-2350	Ø600	195
6.000	7100067140	2820 x 1800 x 2050-2350	Ø600	235

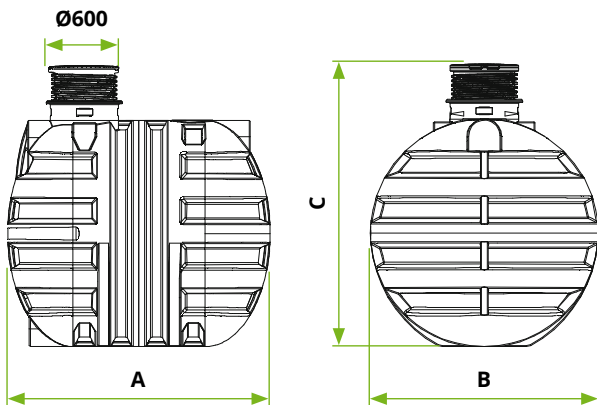
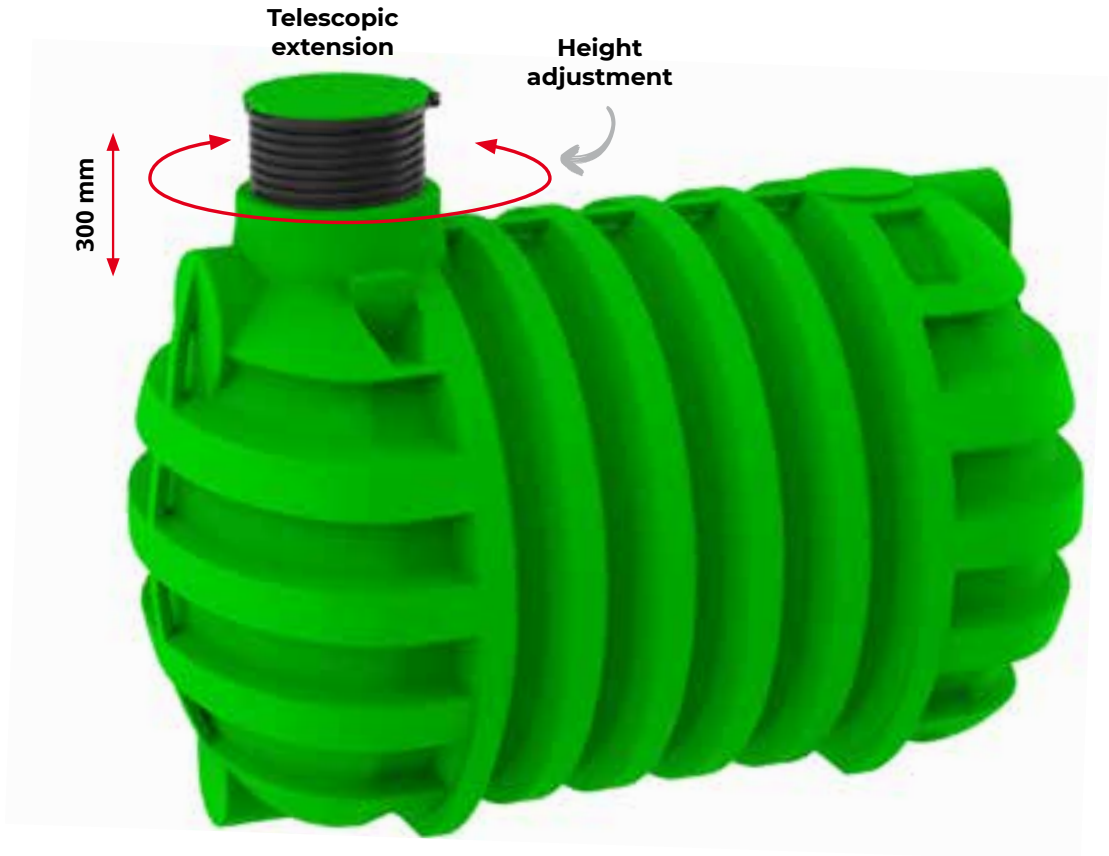

Volume [L]	Code	Dimensions A x B x C [mm]	Cover [mm]	Weight [kg]
8.000	7100062540	2680 x 2300 x 2550-2850	Ø600	275
10.000	7100069030	3040 x 2300 x 2550-2850	Ø600	315
12.000	7100062500	3760 x 2300 x 2550-2850	Ø600	365
16.000	7100065770	4840 x 2300 x 2550-2850	Ø600	465

# Roterra 2450

Water tanks

Waste water treatment plants

Septic tanks

Grease separators

Oil separators

Shafts

Pumping stations

### COVER DN 600 WITH TELESCOPIC EXTENSION

The Roterra tank cover with gasket and hinged opening ensures effective water tightness. The loading capacity of the PE cover is up to 200 kg.

### DN 800 COVER OPTIONAL WITH ADDITIONAL ADAPTER

With an additional adapter, a DN 800 hinged cover can be installed.



FLAT SURFACE FOR PIPE CONNECTIONS

INFLOW



OUTFLOW

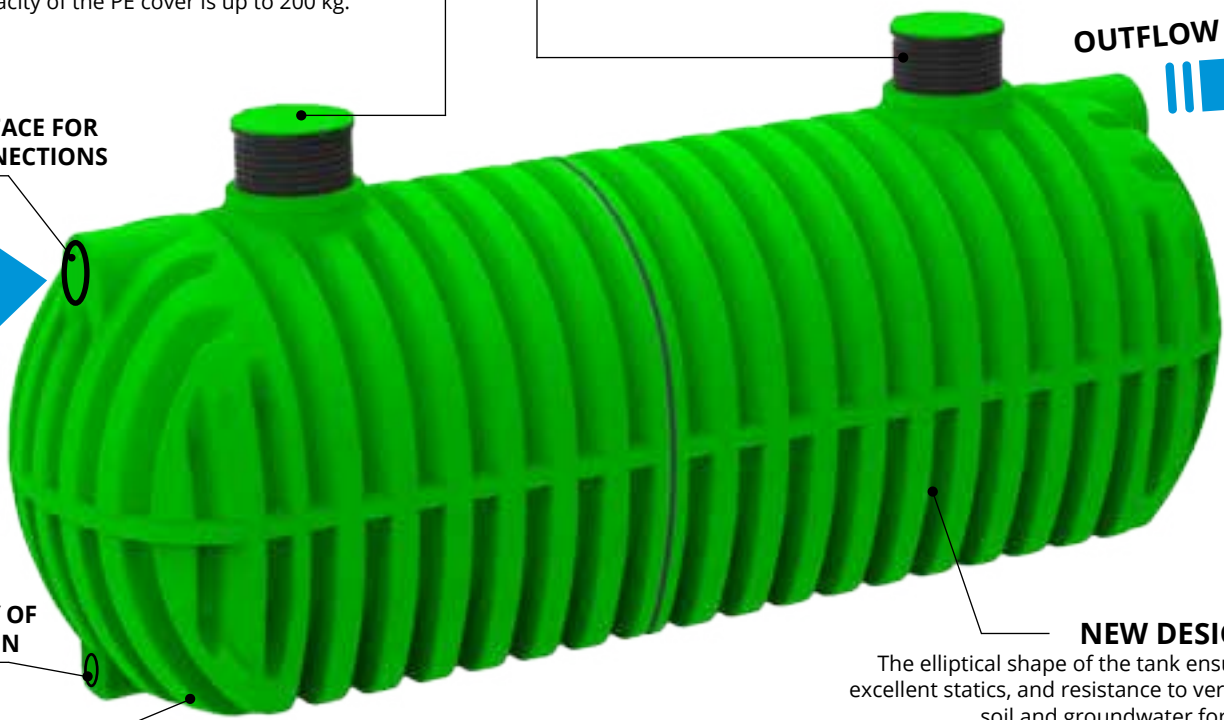

POSSIBILITY OF CONNECTION

### INSTALLATION

The levelled bottom makes installation quick and easy. The new design requires less filling material.

### NEW DESIGN

The elliptical shape of the tank ensures excellent statics, and resistance to vertical soil and groundwater forces.

## Roterra 2450 water tank features:



Tank for underground installation



Material: polyethylene



Excellent statics, resistance to earth pressures and external forces



Wall thickness 8 - 14 mm



Possibility to adjust the height of the extension to the requirements of the terrain



The product can be 100% recycled after use

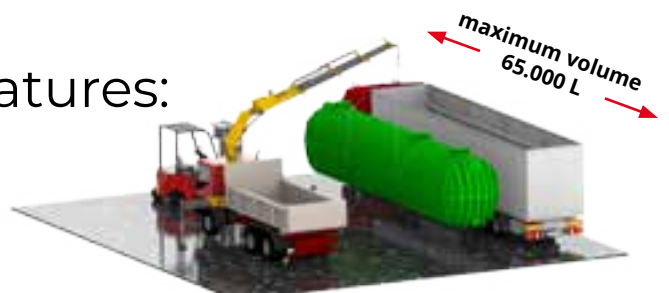

Up to 65,000 L can be transported with one truck

BASIC EQUIPMENT INCLUDES: telescopic extension and lid.



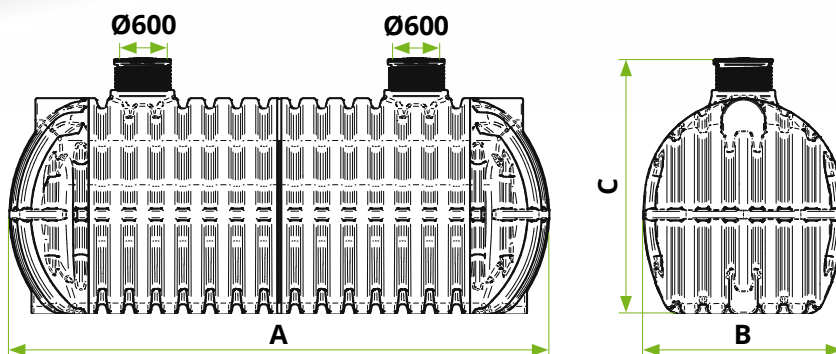
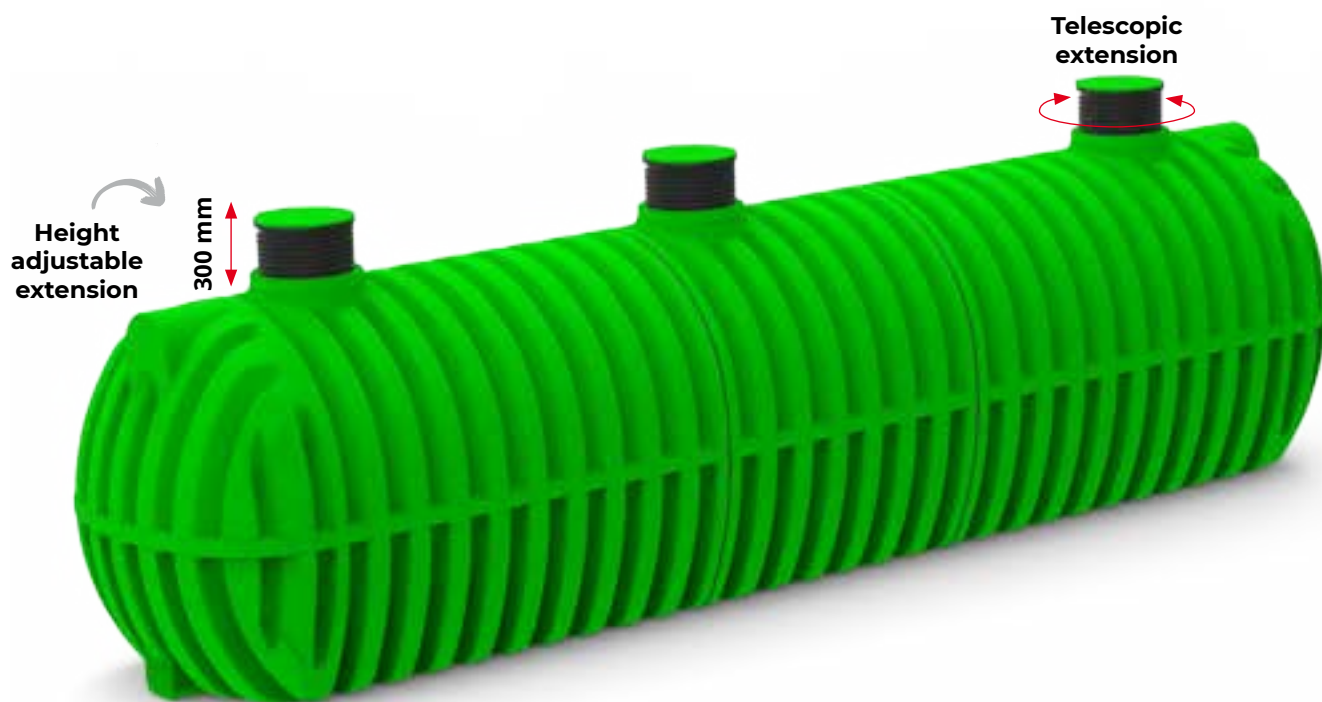

Volume [L]	Code	Dimensions A x B x C [mm]	Inspection opening [mm]	Weight [kg]
20.000	7100062670	4540 x 2450 x 2800 - 3100	Ø600	650
25.000	7100062700	5720 x 2450 x 2700 - 3000	Ø600	780
30.000	7110030000	6550 x 2425 x 2700 - 3000	2 x Ø600	990
35.000	7110035000	7530 x 2425 x 2700 - 3000	2 x Ø600	1140
40.000	7110040000	8510 x 2425 x 2700 - 3000	2 x Ø600	1290
45.000	7110045000	9870 x 2425 x 2700 - 3000	3 x Ø600	1560
50.000	7110050000	10850 x 2425 x 2700 - 3000	3 x Ø600	1700
55.000	7110055000	11500 x 2425 x 2700 - 3000	3 x Ø600	1770
60.000	7110060000	12480 x 2425 x 2700 - 3000	3 x Ø600	1920
65.000	7110065000	13460 x 2425 x 2700 - 3000	3 x Ø600	2070

Water tanks

Waste water  
treatment plants

Septic tanks

Grease separators

Oil separators

Shafts

Pumping stations

# Rocko

## PE COVER WITH ADAPTER

The cover with gasket and hinged opening ensures effective watertightness. The load capacity of the PE DN 600 cover is up to 200 kg.

## PE RING

It allows easy installation of an additional tank extension and thus easy adjustment to the terrain.

## INTEGRATED EXTENSION

The extension of the ROTO Rocko tanks can be cut off so that the height can be adjusted to the terrain.

INFLOW



OUTFLOW



POSSIBILITY OF CONNECTION

## HOLES FOR ANCHORING

They make it easier to attach tank to a concrete slab in case of anchoring due to high groundwater.

## REINFORCING RIBS

Reinforcing ribs on both sides ensure the stability of the tank and protection in case of high water tables.



Rocko tanks can be used as an **UNDERGROUND** or **OVERGROUND** water tank.

## Rocko water tank features:



Underground OR overground water tank



Material: polyethylene



Made in one piece, 100% waterproof



Excellent statics, resistance to earth pressures and external forces



Wall thickness 8 - 14 mm



Possibility to adjust the height of the extension to the requirements of the terrain



The product can be 100% recycled after use

BASIC EQUIPMENT INCLUDES: hinged cover with adapter.

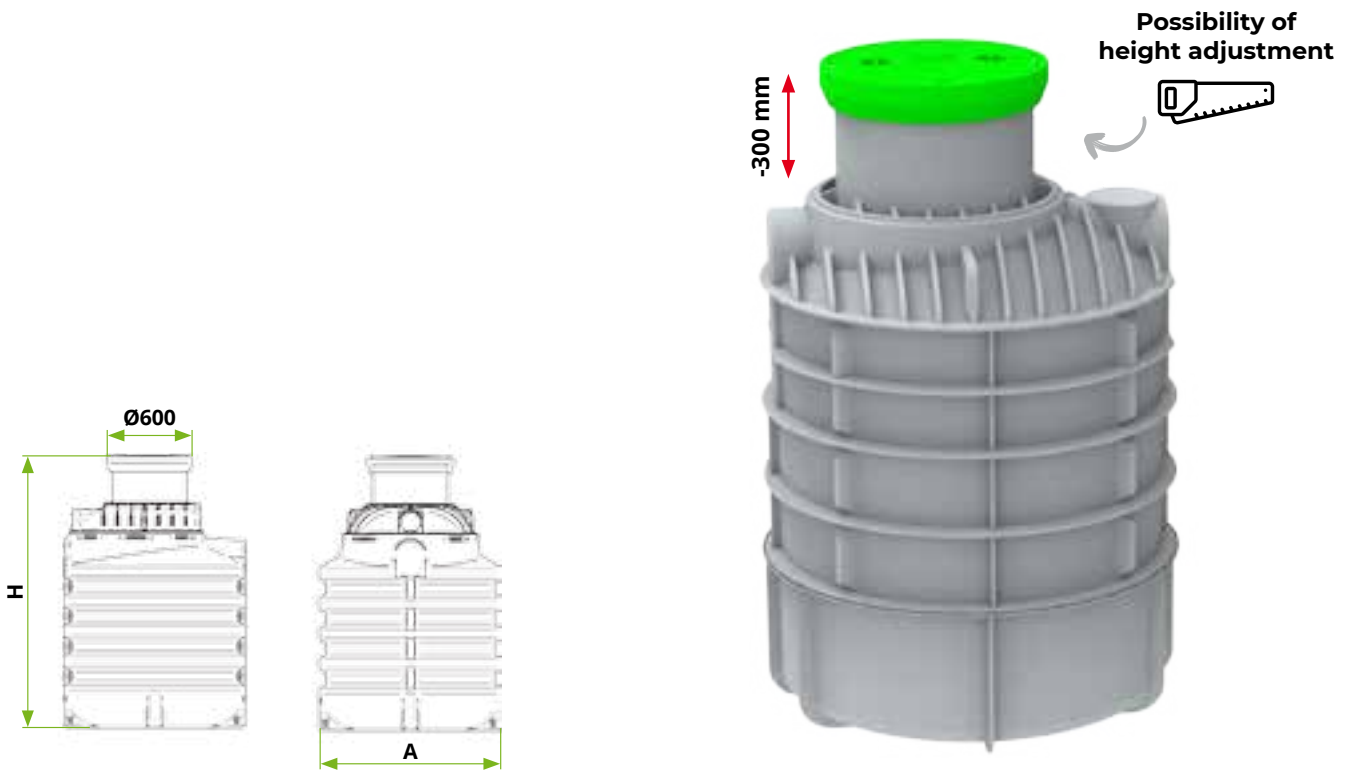

Volume [L]	Code	Dimensions A x H [mm]	Inspection opening [mm]	Weight [kg]
1.200	7100057620	Ø1300 x 1550	Ø600/800	50
1.500	7100057630	Ø1300 x 1800	Ø600/800	65
1.700	7100057810	Ø1300 x 2050	Ø600/800	80
2.000	7100057640	Ø1300 x 2300	Ø600/800	95
2.300	7100057650	Ø1300 x 2550	Ø600/800	115
2.500	7100057840	Ø1300 x 2800	Ø600/800	130
2.800	7100057660	Ø1300 x 3050	Ø600/800	145
3.000	7100057860	Ø1300 x 3300	Ø600/800	160

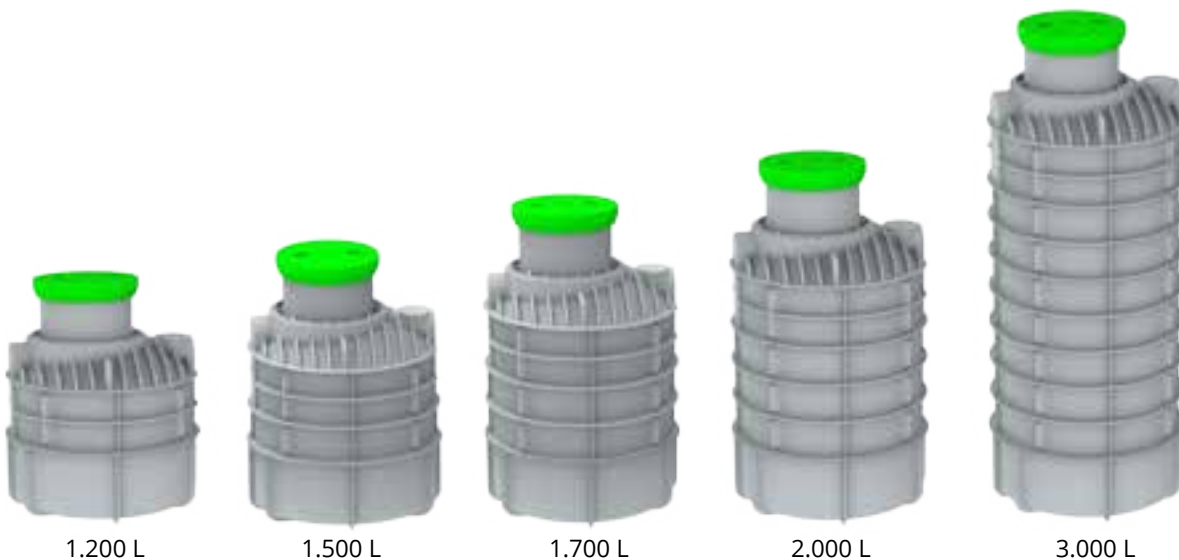

1.200 L

1.500 L

1.700 L

2.000 L

3.000 L

Water tanks

Waste water treatment plants

Septic tanks

Grease separators

Oil separators

Shafts

Pumping stations

Possibility of  
height adjustment



-300 mm

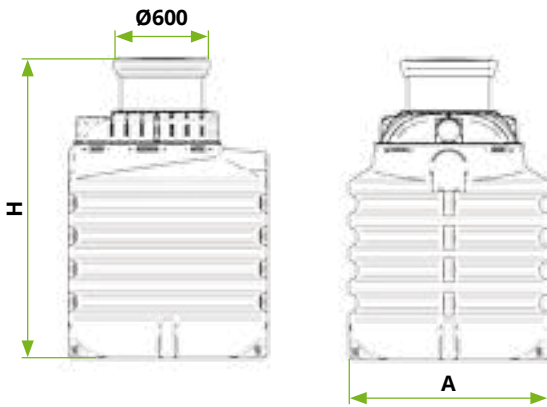

Volume [L]	Code	Dimensions A x H [mm]	Inspection opening [mm]	Weight [kg]
2.000	7100067450	Ø1500 x 2000	Ø600	79
2.350	7100067460	Ø1500 x 2250	Ø600	90
2.700	7100067470	Ø1500 x 2500	Ø600	101



2.000 L

2.350 L

2.700 L

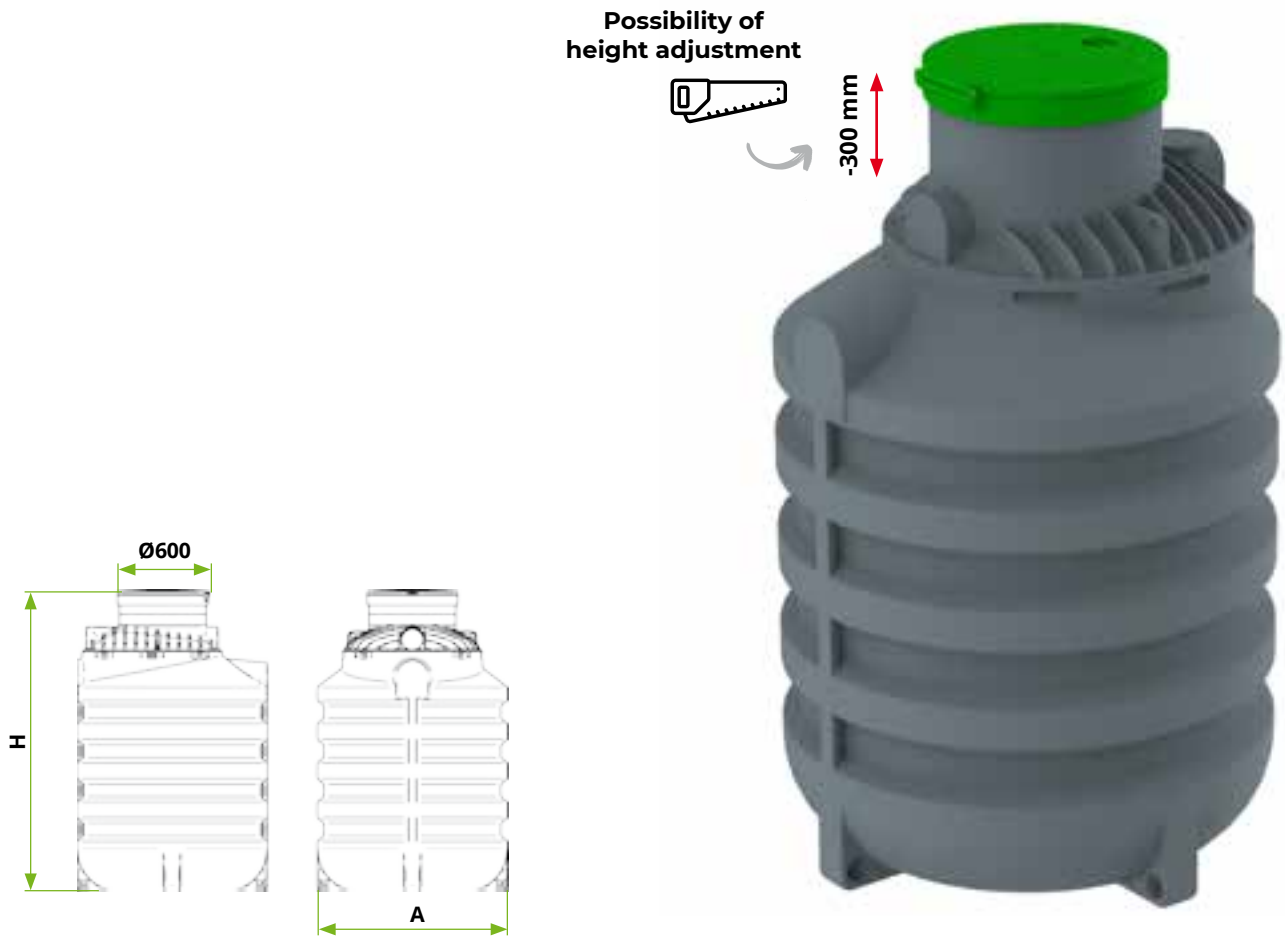

Volume [L]	Code	Dimensions A x H [mm]	Inspection opening [mm]	Weight [kg]
3.200	7100067260	Ø1800 x 2350	Ø800	136
4.000	7100067270	Ø1800 x 2700	Ø800	155
5.000	7100067280	Ø1800 x 3100	Ø800	182



Water tanks

Waste water treatment plants

Septic tanks

Grease separators

Oil separators

Shafts

Pumping stations

Water tanks

Waste water treatment plants

Septic tanks

Grease separators

Oil separators

Shafts

Pumping stations

Possibility of height adjustment



-300 mm

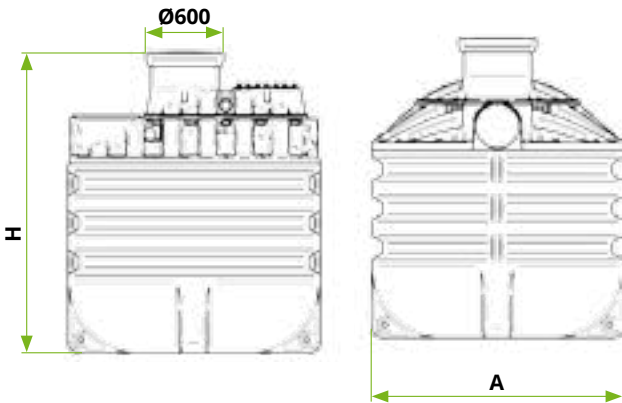

Volume [L]	Code	Dimensions A x H [mm]	Inspection opening [mm]	Weight [kg]
6.000	7100067340	Ø2300 x 2400	1 x Ø800	221
7.500	7100067350	Ø2300 x 2750	1 x Ø800	252
8.700	7100067360	Ø2300 x 3100	1 x Ø800	283
10.000	7100067370	Ø2300 x 3500	1 x Ø800	315



Possibility of adjustment



-300 mm



Rodrink tanks are certified for drinking water:

**REG2-0004-04-ZGPro1-2731**

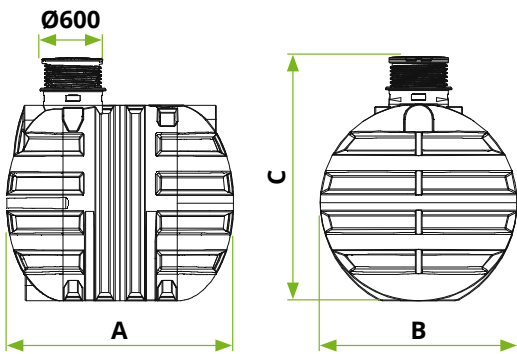

Volume [L]	Code	Dimensions A x B x C [mm]	Inspection opening [mm]	Weight [kg]
2.200	7100067161	1840 x 1400 x 1600	Ø600	100
3.000	7100067171	2400 x 1400 x 1600	Ø600	130
5.000	7100090411	2450 x 1800 x 2050	Ø600	195
6.000	7100090421	2820 x 1800 x 2050	Ø600	235
8.000	7100062541	2680 x 2300 x 2350	Ø600	275
10.000	7100069031	3040 x 2300 x 2350	Ø600	315
12.000	7100062501	3760 x 2300 x 2350	Ø600	365
16.000	7100065771	4840 x 2300 x 2350	Ø600	465

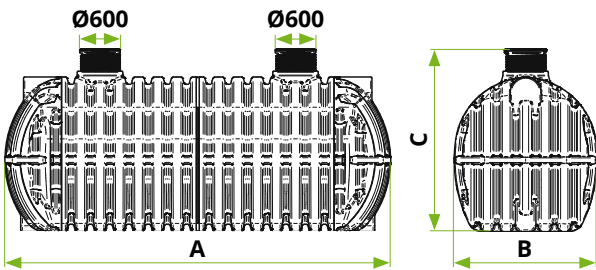
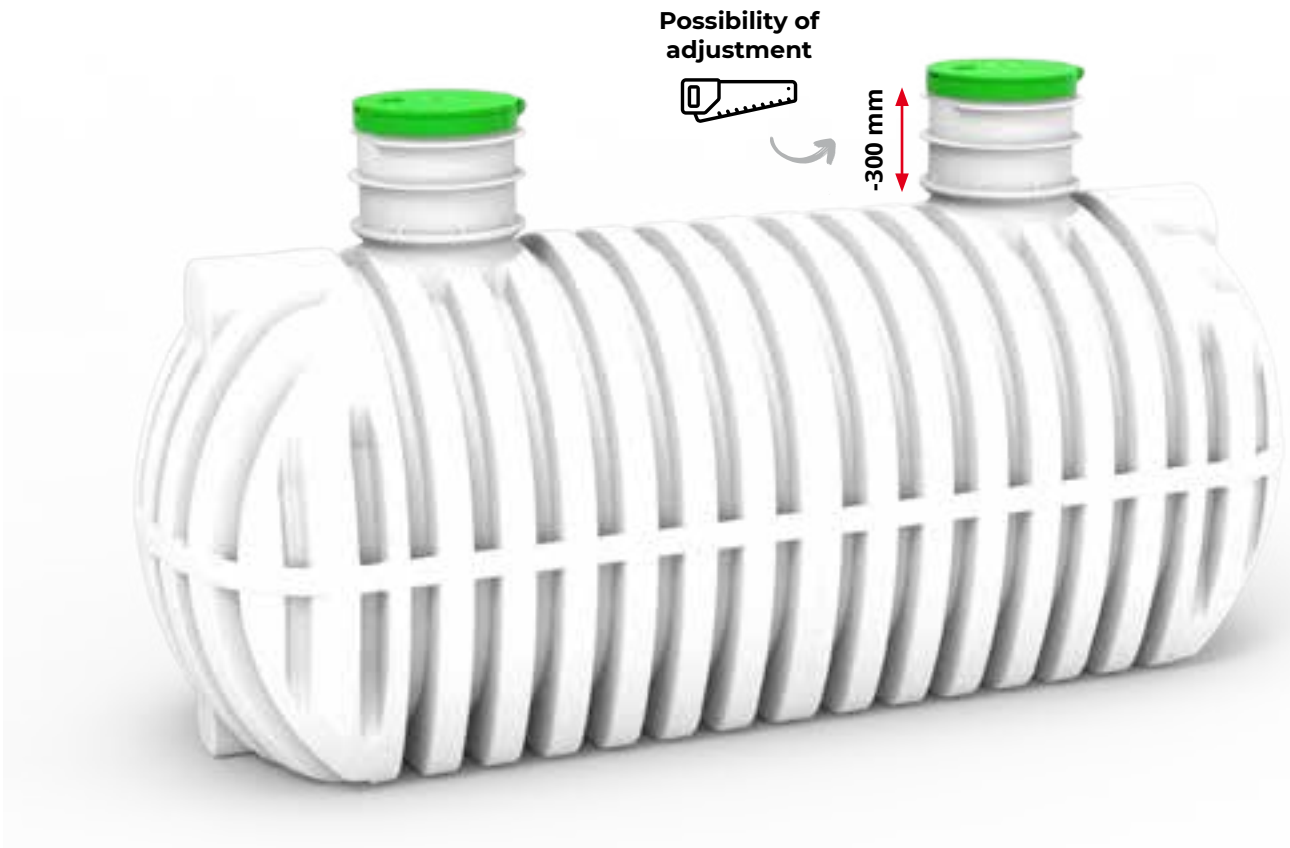

Volume [L]	Code	Dimensions A x B x C [mm]	Inspection opening [mm]	Weight [kg]
20.000	7100062670	4540 x 2450 x 2800 - 3100	Ø600	650
25.000	7100062701	5720 x 2420 x 2700 - 3000	2 x Ø600	690
30.000	7110030000	6550 x 2425 x 2700 - 3000	2 x Ø600	990
35.000	7110035000	7530 x 2425 x 2700 - 3000	2 x Ø600	1140
40.000	710040000	8510 x 2425 x 2700 - 3000	2 x Ø600	1290
45.000	7110045000	9870 x 2425 x 2700 - 3000	3 x Ø600	1560
50.000	7110050000	10850 x 2425 x 2700 - 3000	3 x Ø600	1700
55.000	7110055000	11500 x 2425 x 2700 - 3000	3 x Ø600	1770
60.000	7110060000	12480 x 2425 x 2700 - 3000	3 x Ø600	1920
65.000	7110065000	13460 x 2425 x 2700 - 3000	3 x Ø600	2070

**HINGED COVER**

The Roterra tank lid with gasket ensures water tightness. The lid is hinged to the telescopic extension, making it easy to open.

**TELESCOPIC EXTENSION**

Threaded extension can be simple adjusted to the height of the terrain.

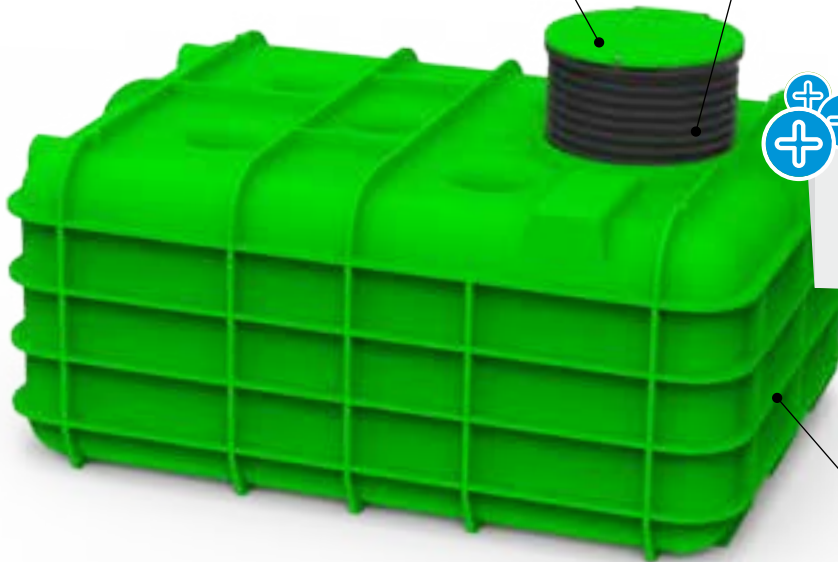

Up to 14 tanks can be transported with a semi-trailer.



**REINFORCEMENT RIBS**

Reinforcement ribs on both sides ensure the stability of the tank and protection in case of high water level.



**ADAPTER FOR FINE FILTER**

For quick and easy installation of a fine filter and soothing siphon. At the same time we achieve a slight increase in the volume of the tank. Available as additional equipment.

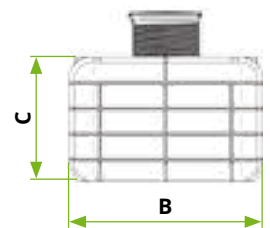
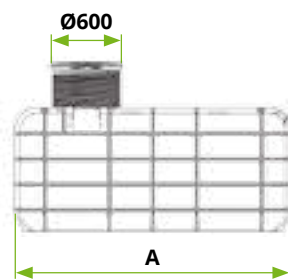

Volume [L]	Code	Dimensions A x B x C [mm]	Inspection opening [mm]	Weight [kg]
5.000	7100072290	2690 x 1890 x 1200	Ø600	200

Roquadro are the ideal choice for above-ground or basement. Their dimensions make them **easy to transport through normal front doors** and they are also very suitable as an **outdoor rainwater collecting tank**.

**Extremely smooth walls for easy cleaning** and a flat bottom to ensure the stability of the tank.

Volume [L]	Code	Dimensions A x B x C [mm]	Inspection opening [mm]	Weight [kg]
250	7104103260	600 x 600 x 928	Ø300	12
500	7104104060	760 x 760 x 1100	Ø300	23
750	7104106060	760 x 760 x 1600	Ø300	30
1.000	7104107660	760 x 1520 x 1100	Ø300	45
2.000	7104109460	760 x 2250 x 1600	Ø300	80

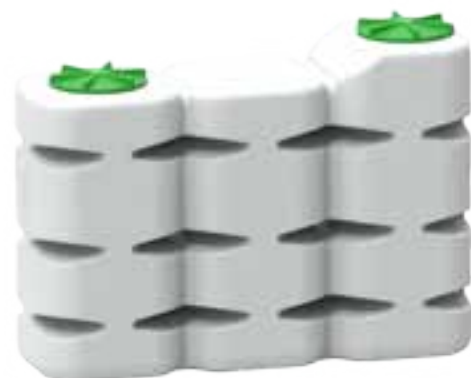

## RoQuadro

**Rondo** water tanks are made of polyethylene. They are the ideal choice for above-ground or basement tanks.

Volume [L]	Code	Dimensions A x H [mm]	Inspection opening [mm]	Weight [kg]
325	7100527300	Ø620 x 1300	Ø200	12
500	7100527310	Ø740 x 1350	Ø300	26
800	7100527320	Ø840 x 1600	Ø500	30
1.000	7100527330	Ø950 x 1650	Ø300	34
1.500	7100527340	Ø1100 x 1850	Ø300	40
2.000	7100527350	Ø1200 x 1950	Ø380	60
3.000	7100527400	Ø1860 x 1430	Ø435	65
4.000	7100527410	Ø1860 x 1920	Ø435	75
5.000	7100077620	Ø1585 x 2825	Ø370	160
6.000	7100527420	Ø1860 x 2590	Ø435	125
8.000	7100527430	Ø2460 x 2020	Ø635	140
10.000	7100527440	Ø2460 x 2470	Ø635	220
15.000	7100527450	Ø2460 x 3620	Ø635	430



## Rondo

**Rotrans** water tanks are made of polyethylene and are therefore suitable for storing water. They are the ideal choice for above-ground storage and transport of liquids.

Volume [L]	Code	Dimensions A x B x C [mm]	Inspection opening [mm]	Weight [kg]
300	7100527200	1220 x 590 x 660	Ø435	13
500	7100527210	1440 x 680 x 820	Ø435	17
1.000	7100527220	1730 x 870 x 1010	Ø435	28
1.500	7100527230	1610 x 1180 x 1310	Ø435	35
2.000	7100527240	1720 x 1250 x 1400	Ø435	47
3.000	7100527250	2030 x 1430 x 1600	Ø435	67
5.000	7100527260	2150 x 1840 x 1960	Ø435	130



## Rotrans

## 97%

### HIGH CLEANING EFFICIENCY

ROTO treatment plants purify water up to 97.2%. They operate safely and reliably, are virtually silent and odourless, and are insensitive to fluctuations in the ambient temperature. Urban waste water from toilets, bathrooms, kitchens and similar sources of pollution in houses is treated to the point where it can be safely discharged into surface water or a seepage pond.



### RELIABILITY AND TRUST

ROTO is a pioneer in the production of waste water treatment plants in Slovenia, Europe and around the world. Several thousand ROTO waste water treatment plants ranging from 3 to 2500 units, septic tanks, oil and grease separators and water tanks have been installed. The award from the ZRMK Institute of Civil Engineering confirms the excellence of the product as judged by the building profession.



### 24H SERVICE

We guarantee fast delivery, maintenance, commissioning and servicing by ROTO's expert staff. Servicing by ROTO includes checking the condition and operation of the waste water treatment plant components, the cleaning efficiency, and checking the operational status as well as testing all plant functions. We instruct the user on the maintenance and correct use of the waste water treatment plant, and can also organise or supervise the installation and burial.



### EASY INSTALLATION

Installation of the waste water treatments plants is fast and simple. Dig a construction pit, install a treatment plant, fill it with water and connect it with the inflow of wastewater from the house. The tank of the treatment plant has a telescopic extension, so the height of the tank can be adjusted to the requirements of the terrain.



### 100% RECYCLING

The waste water treatment plant can be dismantled after use and the polymer components can be fully recycled.



### LOW OPERATING COSTS

Water purification is Easy, because all the components of the waste water treatment plant work on air-lift pump principle. The air compressor is located in the separate cabinet where it is protected from the environment, which reduces the potential for failures and makes the wastewater treatment plant extremely efficient, with yearly running costs under 6 €/year/person.



### LONG LIFETIME

The waste water treatment plant tank is made of polyethylene, which has a service life of 50 years. It is made in one piece, so it is 100% waterproof. The waste water treatment plant tank has excellent statics and walls which are 8-14 mm thick, making it resistant to soil pressures and external influences.



### EASY SAMPLING

All ROTO waste water treatment stations have a built-in sampling container from which we can check the purifying efficiency of the plant.



### PROFESSIONAL CONTROL UNIT

The cleaning device works fully automatically as it is controlled by a computer built into the cabinet. This robust and stylish cabinet is made of polyethylene. The cabinet design ensures easy access for maintenance, protects the control unit, compressor and valves from external influences and thus prolongs their service life. The cabinets are available in different sizes, designs (free-standing or wall-mounted) and materials (polyethylene and concrete). Control units can be upgraded with remote monitoring – telemetry.



### UNDERGROUND INSTALLATION

The waste water treatment plants are intended for underground installation, so when installed the treatment plant wont in any way affect your landscape or take up any additional space.



### QUICK DELIVERY

Roto is Slovenian manufacturer. Delivery can be made in few days after the order



### EU PRODUCT

ROTO WWTP's are 100% Slovenian product. Our factory has its own development, production and assembly line in Puconci near Murska Sobota (Slovenia). Roto waste water treatment plants are made according to the EU standards EN 12566-3 and reach purification stage BPK<sub>5</sub> < 30mg/l, KPK < 150 mg/l



Water tanks

Waste water treatment plants

Septic tanks

Grease separators

Oil separators

Shafts

Pumping stations

# EcoBox

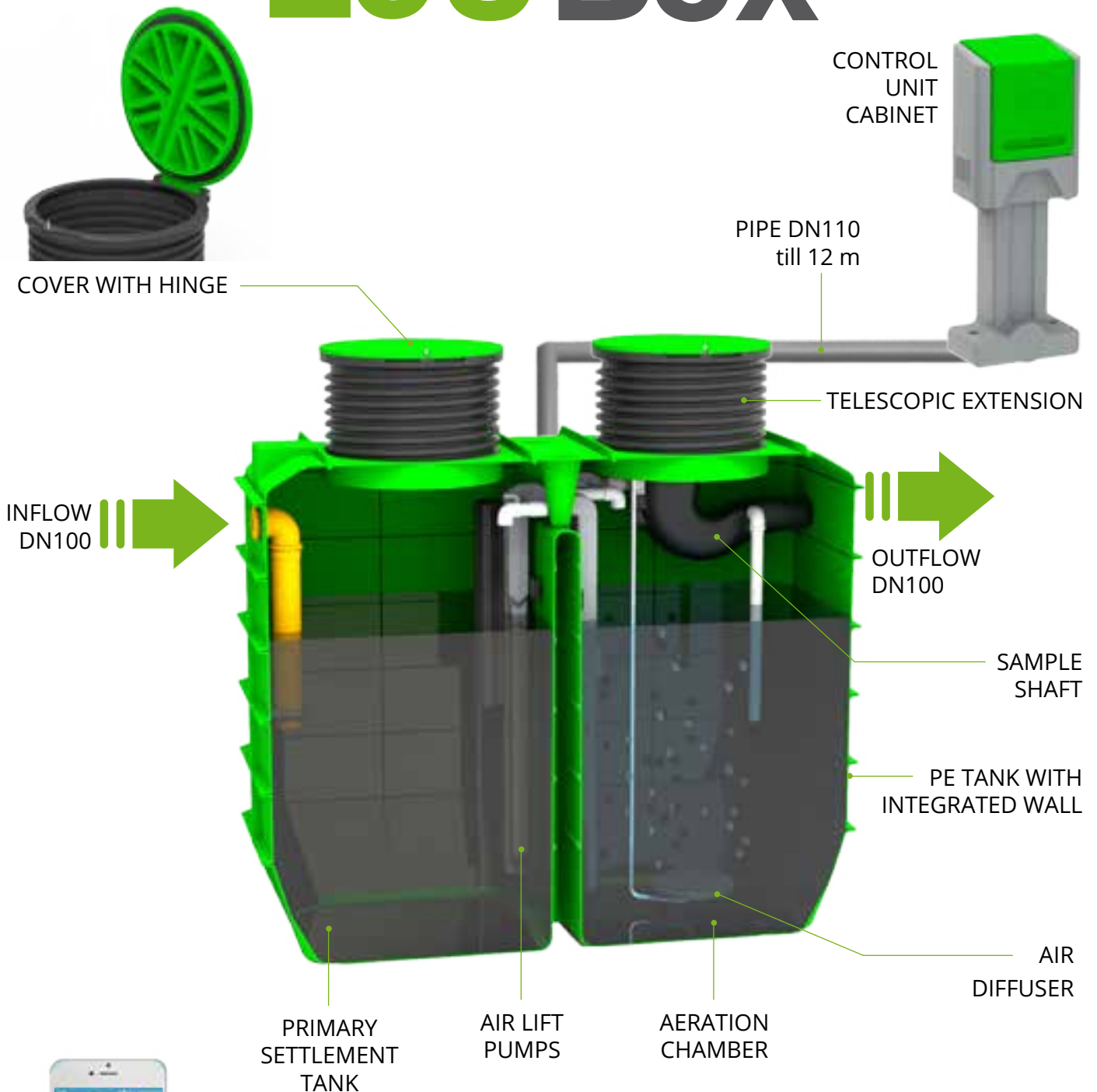

**roWEB**  
Web application for remote control and operating mode



## SBR TECHNOLOGY:

Process is managed by computer which is installed into the special box. Softwar is steering 4 magnetic valves. Each valve has specific function:

1. Pumping water from mud collector to the aerator.
2. Aeration in aeration chamber.
3. Pumping of purified water from aeration chamber to the outflow.
4. Pumping sediment mud from aerator chamber back to the mud collector

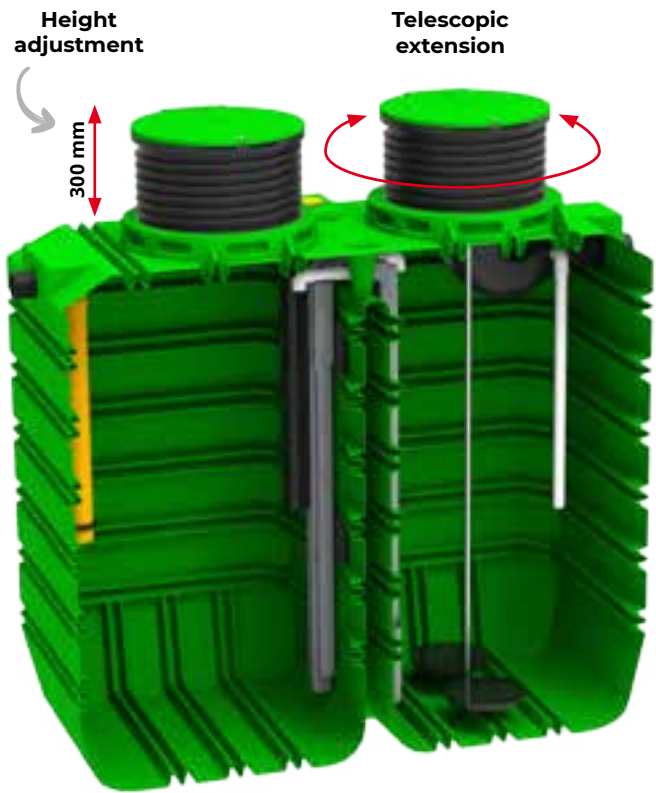
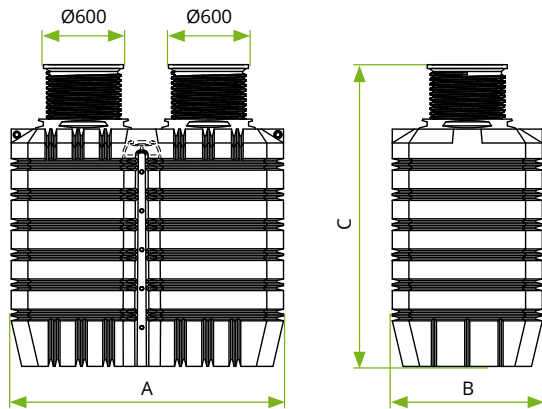

Options of control unit:



PU	2-5 PU	6-9 PU
Code	7100079950	7100076730
Max. day inflow [l/dan]	750	1350
Volume [L]	4000 L	6000 L
Dimension A x B x C [mm]	2330 x 1175 x 2000-2300	2450 x 1350 x 2300-2600
Diameter inspeciton opening	2 x DN600	2 x DN600
Height of inflow/outflow [mm]	1610/1530	1960/1880
Diamater of inflow/outflow pipe	DN 110	DN 110
Airflow volume (compresor) [l/min]	80	150
Power consupcion (compresor) [W]	58	130
Sound level [dB]	36 dB	48 dB
Control system cabinet	P6	P6
Control unit	RC	RC
Sample shaft	5 L	5 L

# Roclean

- Water tanks
- Waste water treatment plants
- Septic tanks
- Grease separators
- Oil separators
- Shafts
- Pumping stations



COVER WITH HINGE

TELESCOPIC EXTENSION

Cover can be simple screwed in the tank and easy adjusted to the terrain. It is compatible with additional extension of the extension in the case of deep ground installation. Dimensions of extensions are  $\varnothing 600 \times 300$  mm.

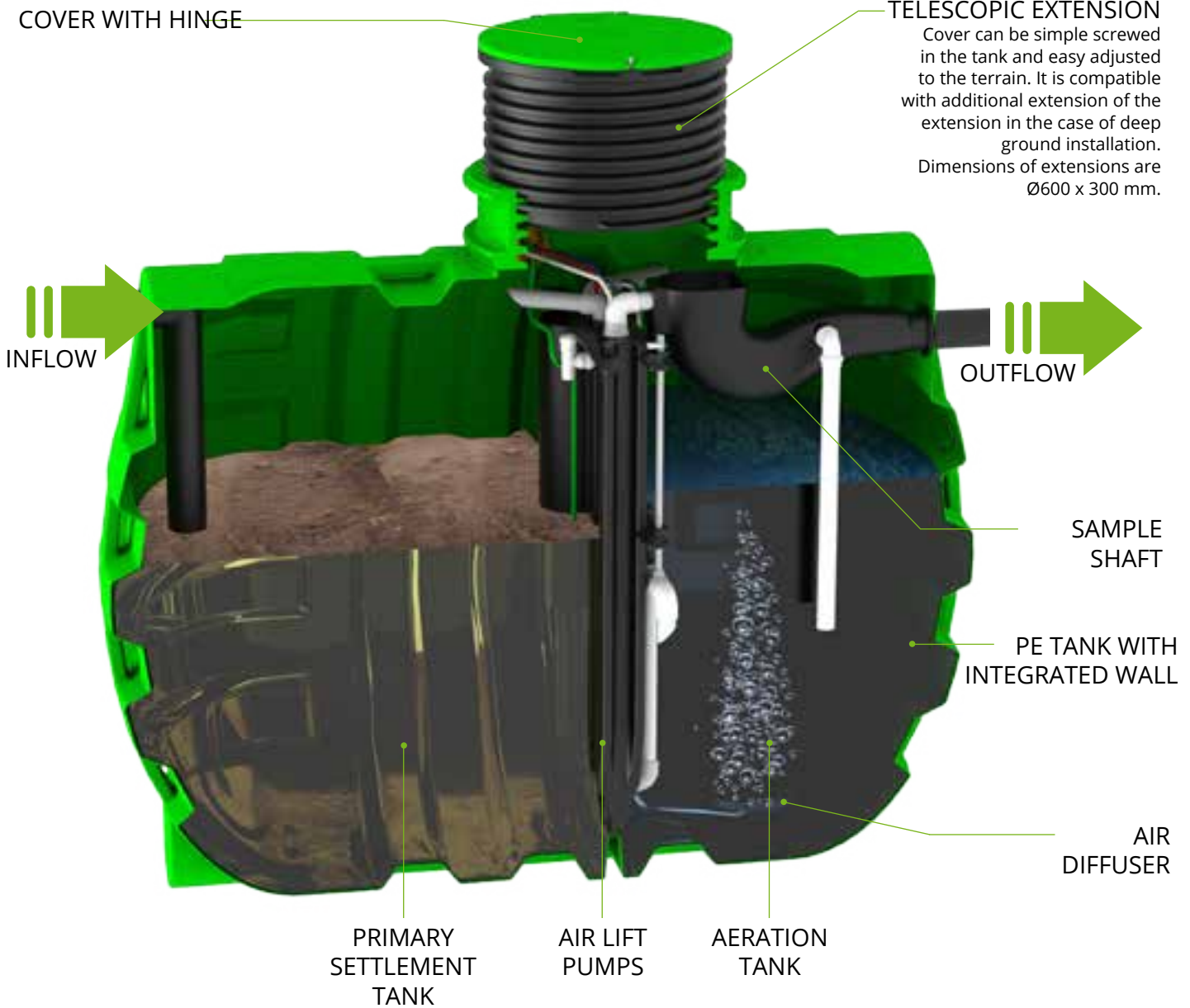

INFLOW

OUTFLOW

SAMPLE SHAFT

PE TANK WITH INTEGRATED WALL

AIR DIFFUSER

PRIMARY SETTLEMENT TANK

AIR LIFT PUMPS

AERATION TANK

## EASY AND SAFE ACCESS

RoClean has an inspection opening DN 600 or DN 800, which allows easy access and maintenance and servicing of the waste water treatment plant.

## TELESCOPIC EXTENSION

The telescopic extension allows quick and easy height adjustment upon installation.

## CONTROL CABINET

Waste water treatment plants up to 75 PE have a polyethylene control unit locker, while those above 100 PE have a concrete control locker. A 3 x 2.5 mm<sup>2</sup> power lead must be connected to the control box to supply the control unit.

## SAMPLE SHAFT

In the case of smaller RoClean units, the sample shaft is integrated and self-cleaning and easily accessible through the inspection opening. For larger waste water treatment plants, it is installed in a DN600 shaft.

## TANK

is made from a single piece of polyethylene using a rotational moulding process. Durability and longevity are ensured by walls with a thickness of 8 mm to 14 mm. Reinforcing ribs improve the tank's strength and resistance to soil pressures.

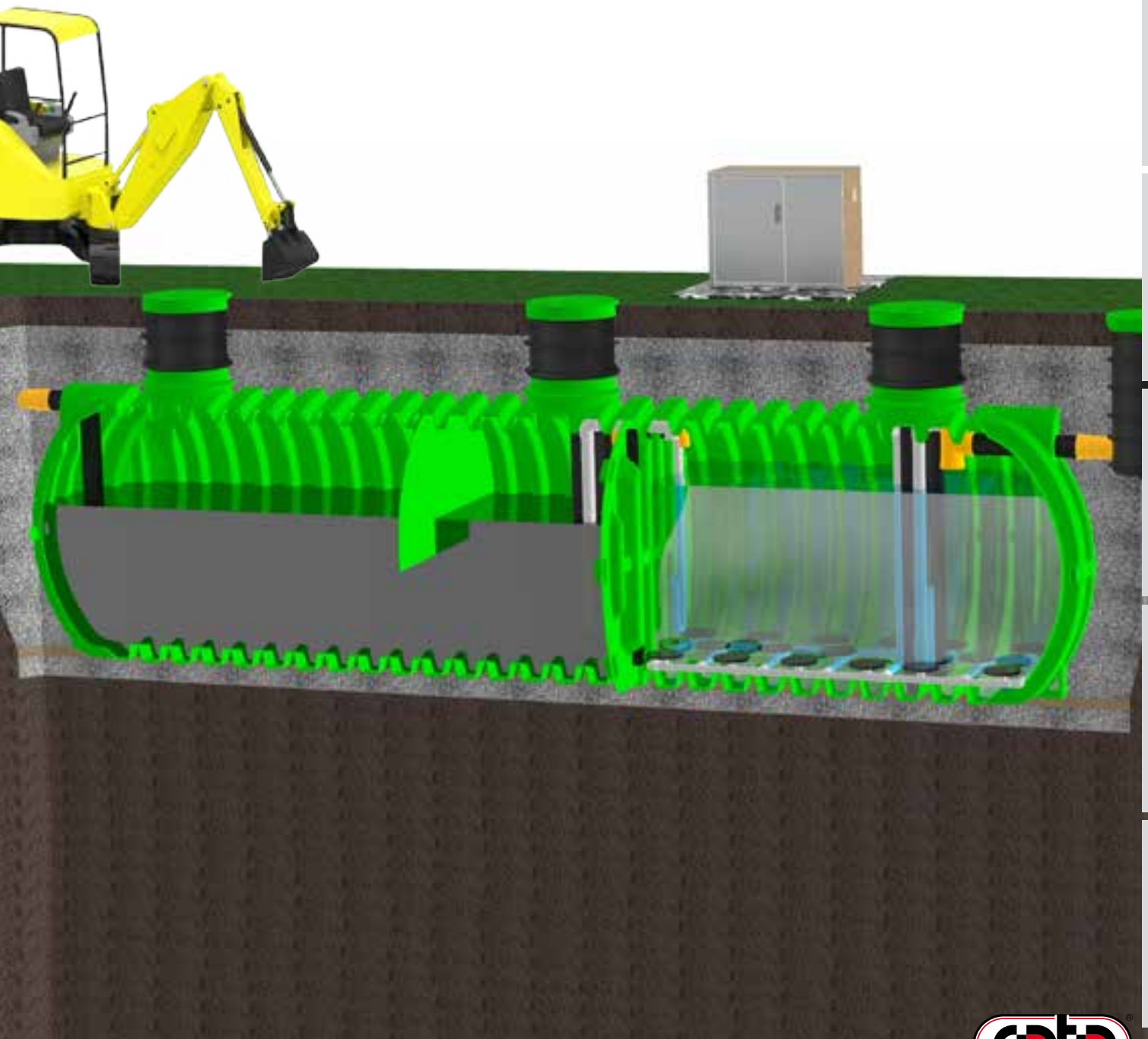

Water tanks

Waste water treatment plants

Septic tanks

Grease separators

Oil separators

Shafts

Pumping stations

Water tanks

RoClean is the ideal waste water treatment plant for small accommodations, hotels, housing estates, apartment buildings, schools, factories and office buildings, campsites, etc., which are not connected to the public sewage network.

The waste water in RoClean water does not flow freely through the system, but its feedes with specific volumes from the storage tank into the SBR reactor, where it is processed through several treatment cycles. This results in different water levels in different tanks.

Waste water treatment plants

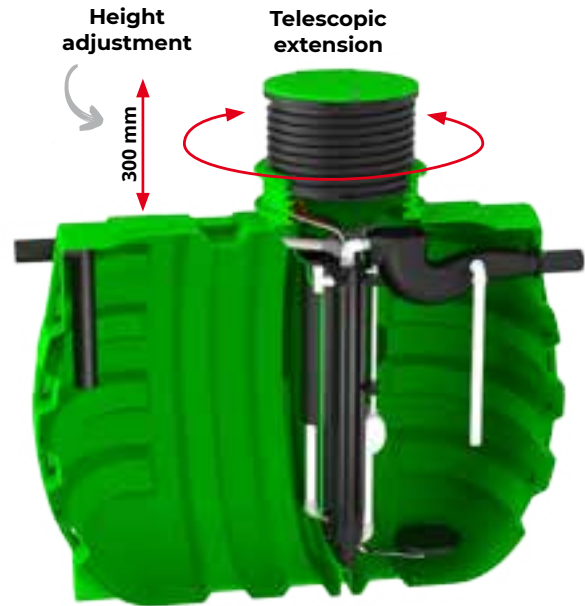

Septic tanks

Grease separators

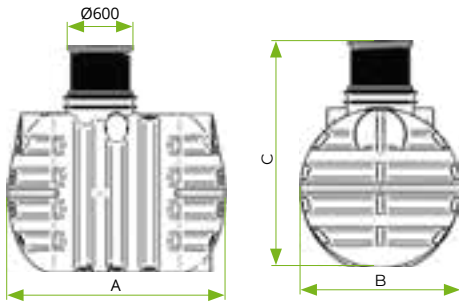

Options of control unit:



Oil separators

Shafts

Pumping stations

PU	4	6	8	12	16	20	30	40	50
Code	7200079840	7200079850	7200079860	7200063770	7200063780	7200063790	7200063760	7200063820	7200063830
Max. day inflow [l/dan]	600	900	1200	1800	2400	3000	5000	6000	8000
Volume [L]	3.500	5.000	6.000	8.000	10.000	12.000	16.000	16.000	20.000
Dimension A x B x C [mm]	2080 x 1800 x 2050 - 2350	2450 x 1800 x 2050 - 2350	2820 x 1800 x 2050 - 2350	2680 x 2300 x 2550 - 2850	3050 x 2300 x 2550 - 2850	3760 x 2300 x 2550 - 2850	4840 x 2300 x 2550 - 2850	4840 x 2300 x 2550 - 2850	6280 x 2300 x 2550 - 2850
Diameter of inspeciton opening	DN600	DN600	DN600	2 x DN600	2 x DN600	2 x DN600	3 x DN600	3 x DN600	3 x DN800
Diamater of inflow/outflow pipe	DN 110	DN 110	DN 110	DN 110	DN 110	DN 125	DN 125	DN 125	DN 125
Airflow volume (compresor) [l/min]	80	80	120	150	200	250	300	300	425
Power consumption (compresor) [W]	58	58	122	130	186	202	298	298	400
Sound level [dB]	36	36	46	48	48	55	56	56	51
Control system cabinet	P6	P6	P6	P6	P6	P5	P5	P5	P5
Control unit	RC/RW/RGSM	RC/RW/RGSM	RC/RW/RGSM	RC/RW/RGSM	RC/RW/RGSM	RC/RW/RGSM	RC/RW/RGSM	RC/RW/RGSM	RC/RW/RGSM
Sample shaft	5 L	5 L	5 L	5 L	5 L	5 L	5 L	5 L	5 L

The RoClean waste water treatment plant is installed in a single tank, which consists of two compartments: the sludge storage tank and the SBR reactor. It works on the airlift pump. It is suitable for the treatment of municipal waste water from settlements, catering and commercial buildings with a constant influx of large volumes of waste water.

RoClean is sized according to SIST EN 12255-1, -4, -6, -10, -11, -12, where a daily flow of 150 L/day/person is foreseen. Treated water may be discharged into watercourses of another category. The control unit is mounted in a polyethylene or concrete cabinet, which is specified by our professionals according to the type of plant and the number of accessories.

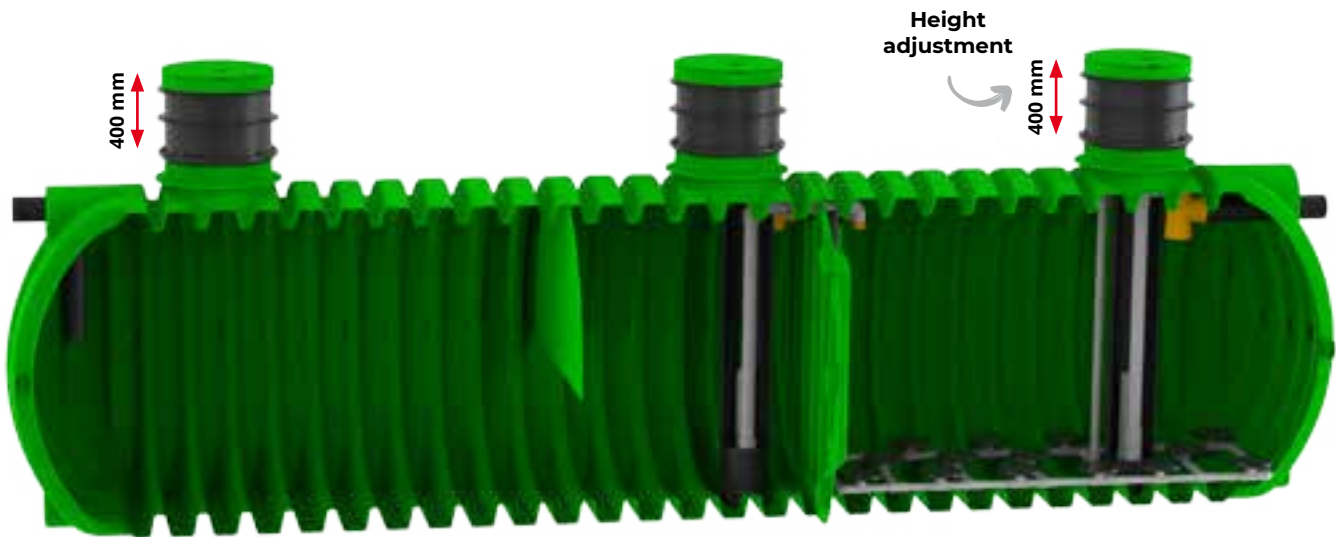

PU	75	100	150	200	300
Code	7200063850	7200063840	7200063860	7200063870	7200063880
Max. day inflow [l/dan]	120000	150000	230000	300000	450000
Volume [L]	25.000	30.000	40.000	50.000	65.000
Dimension A x B x C [mm]	5720 x 2420 x 2700-3000	6620 x 2425 x 2700-3000	8600 x 2425 x 2700-3000	10960 x 2425 x 2700-3000	13600 x 2425 x 2700-3000
Diameter of inspection opening	3 x DN800	2 x DN800	2 x DN800	3 x DN800	3 x DN800
Diameter of inflow/outflow pipe	DN200	DN200	DN200	DN200	DN200
Airflow volume (compressor) [l/min]	35	35	95	95	165
Power consumption (compressor) [W]	700	700	1600	1600	3000
Sound level [dB]	55	55	66	66	72
Control system cabinet	B8	B8	B8	B13	B13
Control unit	RC/RW	RC/RW	RC/RW	RC/RW	RC/RW
Sample shaft	56 L	56 L	56 L	56 L	56 L

Water tanks

Waste water treatment plants

Septic tanks

Grease separators

Oil separators

Shafts

Pumping stations

Fully automated processes and additional sensors allow the waste water treatment plant to automatically adapt its operation to the specifics of the facility. The data collected from the sensors is used by the smart control to modify and optimise the operating regime in order to clean as efficiently as possible and minimise operating costs. A phone app allows you to remotely monitor and control the waste water treatment plant.

RoGreen's smart municipal waste water treatment plant responds automatically to changing influent conditions, which competitors' waste water treatment plants do not provide. This results in higher waste water treatment efficiency, lower electricity consumption and lower maintenance costs as the operator does not have to adjust the operating settings to the changing inflow.

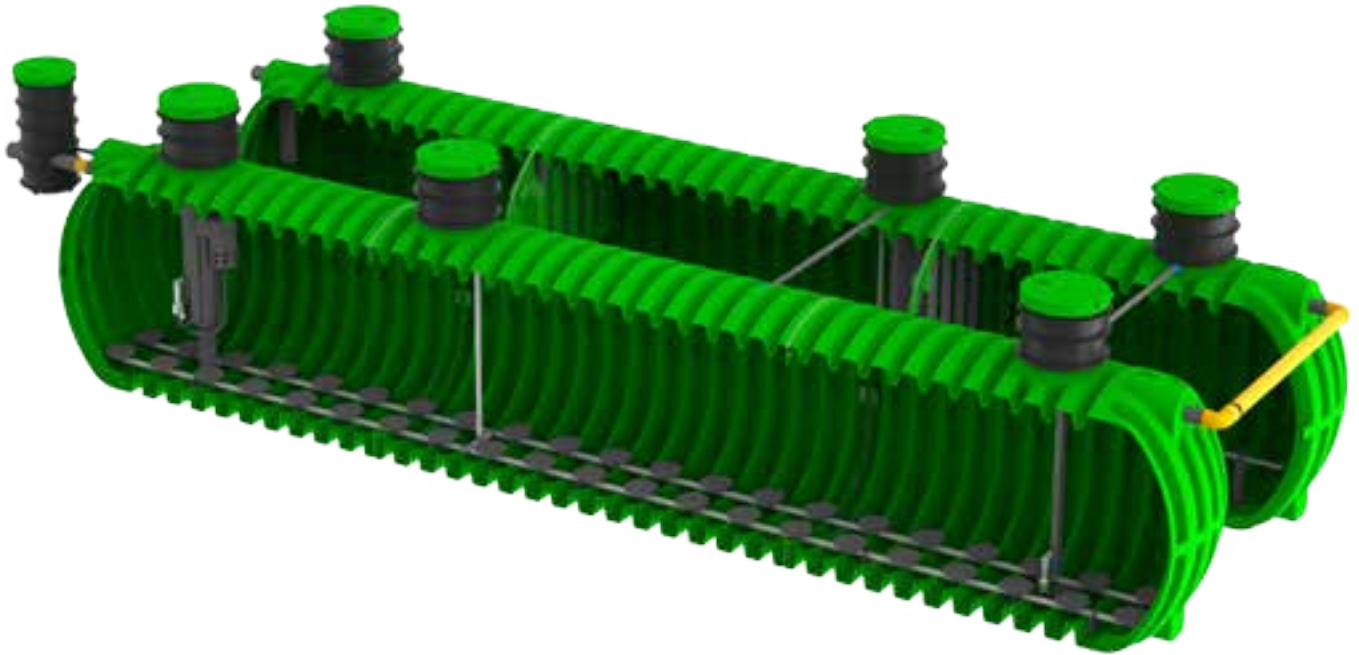

PU	100	150	200	300	400	500
Code	7200063841	7200063861	7200063871	7200063881	7200063891	7200063901
Max. day inflow [l/dan]	15000	22500	30000	45000	60000	75000
Volume [L]	30.000	40.000	50.000	65.000	1x 40.000 1x 45.000	2x 50.000
Dimension A x B x C [mm]	6550 x 2425 x 2700-3000	8510 x 2425 x 2700-3000	10850 x 2425 x 2700-3000	13460 x 2425 x 2700-3000	1x (8510 x 2425 x 2700-3000) 1x (9870 x 2425 x 2700-3000)	2x (10850 x 2425 x 2700-3000)
Diameter of inspection opening	2 x DN600	2 x DN600	3 x DN600	3 x DN600	5 x DN600	6 x DN600
Diameter of inflow/outflow pipe	DN200	DN200	DN200	DN200	DN200	DN200
Airflow volume (compressor) [l/min]	35	95	95	165	265	265
Power consumption (compressor) [W]	700	1600	1600	3000	4000	4000
Sound level [dB]	55	66	66	72	73	73
Control system cabinet	B8	B8	B8	B8	B13	B13
Control unit	Green PRO	Green PRO	Green PRO	Green PRO	Green PRO	Green PRO
Sample shaft	56 L	56 L	56 L	56 L	56 L	56 L

RoGreen PRO 650+ are professional WWTPs for residential or tourist facilities and factories. The waste water treatment plants are built into RoTerra tanks. A computer controls a system of pumps in the waste water treatment plant, which pump water between the chambers and to the outlet, via a PLC. Float switches control the operation of the pumps. We design a professional control system for each project. The RoGreen PRO is easy to maintain as it is designed so that all hardware can be pulled out through the

inspection openings for servicing. The basic version can be upgraded with various accessories. Sensors adjust the processes in the waste water treatment plant to the volume of waste water flow, increasing the efficiency of treatment. Capacity can be increased modularly. The additional SCADA control system allows us to easily remotely control and monitor the waste water treatment plant.

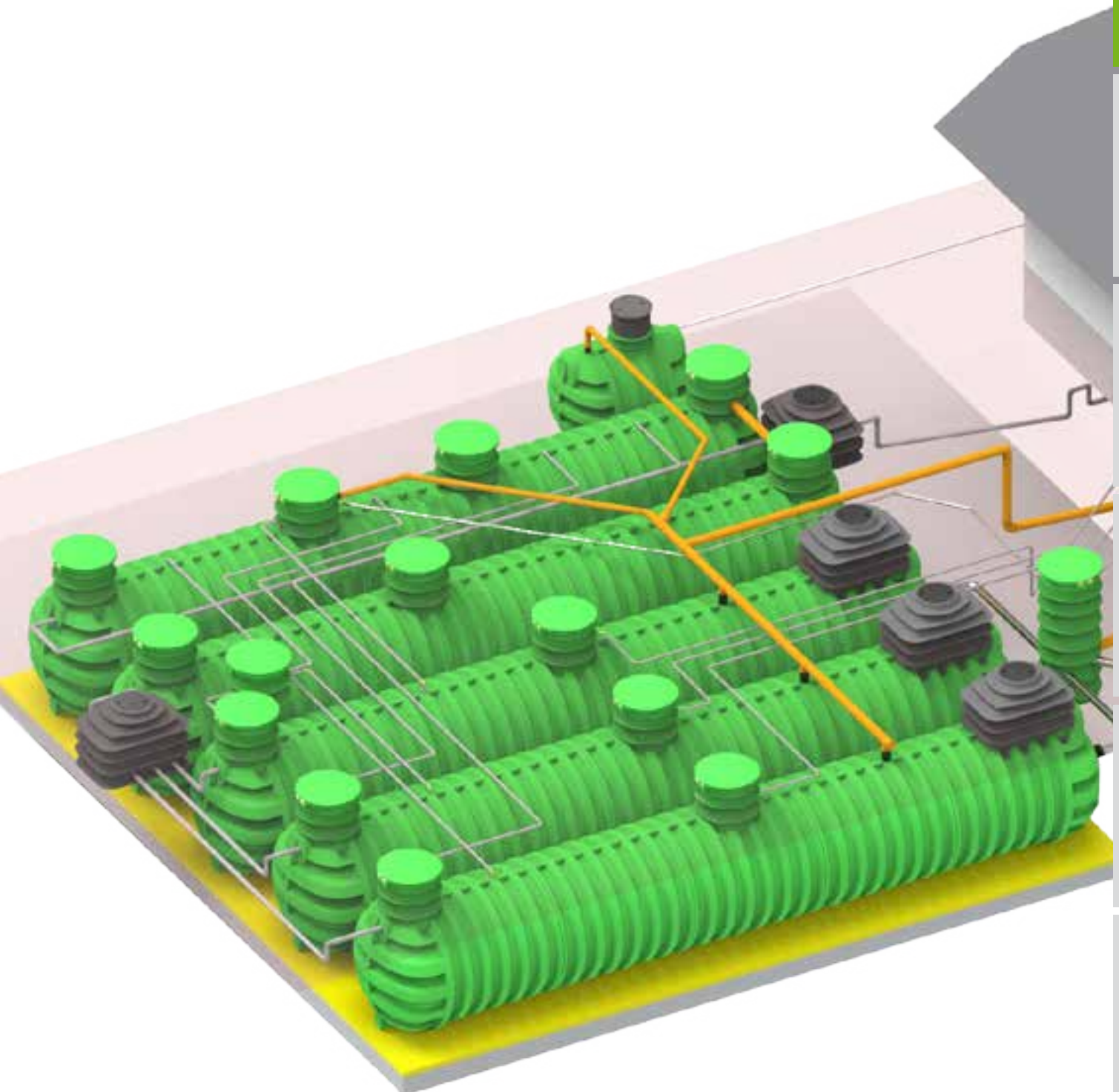

Water tanks

Waste water treatment plants

Septic tanks

Grease separators

Oil separators

Shafts

Pumping stations

# Rotogreen PRO

## 100-2500 PU

Because we recognise the importance of protecting the environment, we closely monitor and control the performance of major waste water treatment plants. With the latest hardware, electrical equipment and information technology, all processes in ROTO waste water treatment plants can be controlled remotely.



solenoid valve

blower

flocculant dosator

fine screen bar

chemical filter

submersible pumps

level probe

flow meter

waste water regulation valve

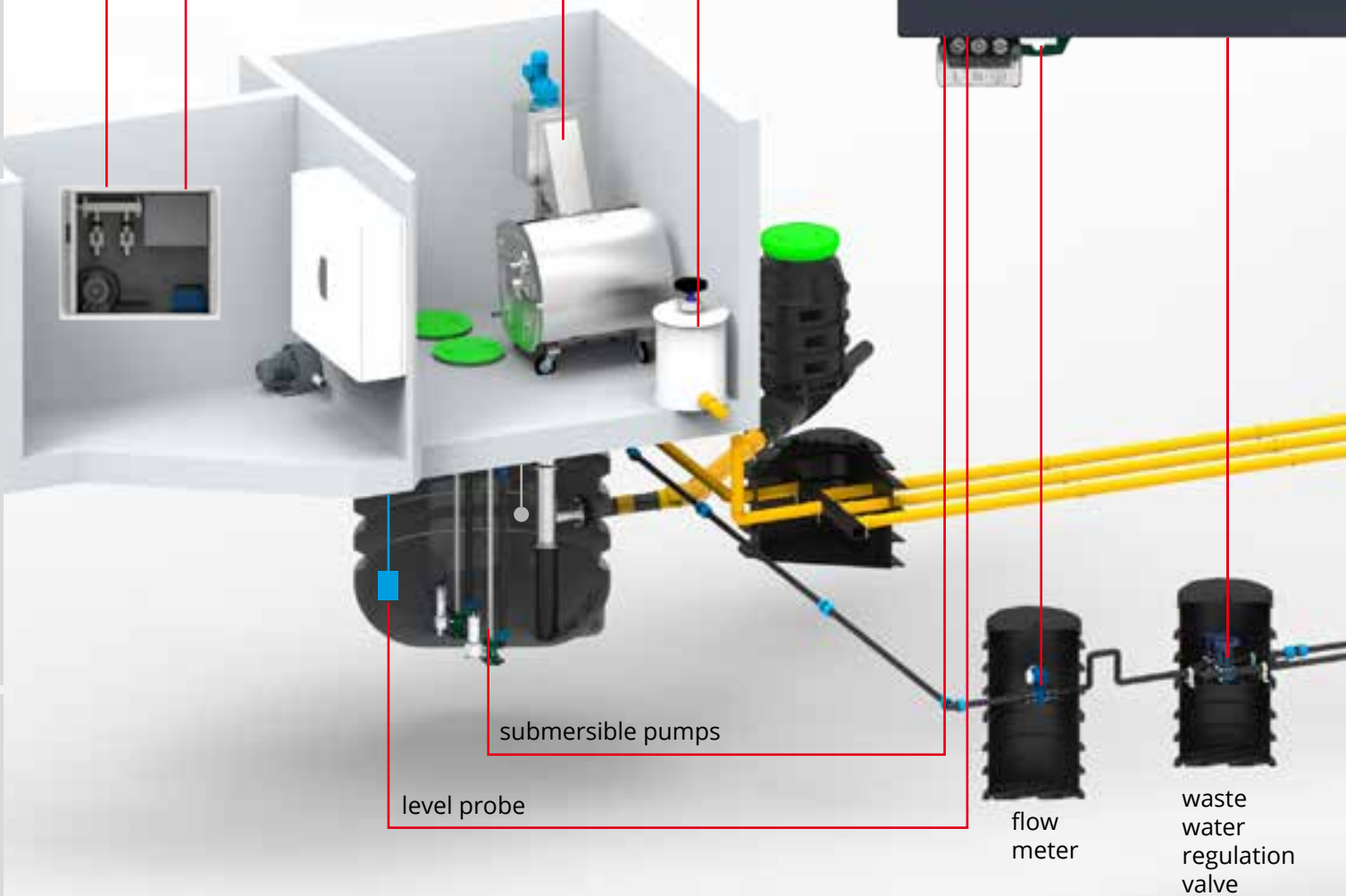

Water tanks

Waste water treatment plants

Septic tanks

Grease separators

Oil separators

Shafts

Pumping stations





The SCADA control system is a quick and transparent way for the user to manage the entire treatment process, while allowing us to adjust the operation according to the influent and effluent parameters.

Data is transmitted from the sensors to the controller and stored in a central control centre. You can remotely control individual components of the waste water treatment plant and monitor the system's performance anytime, anywhere via smart devices.

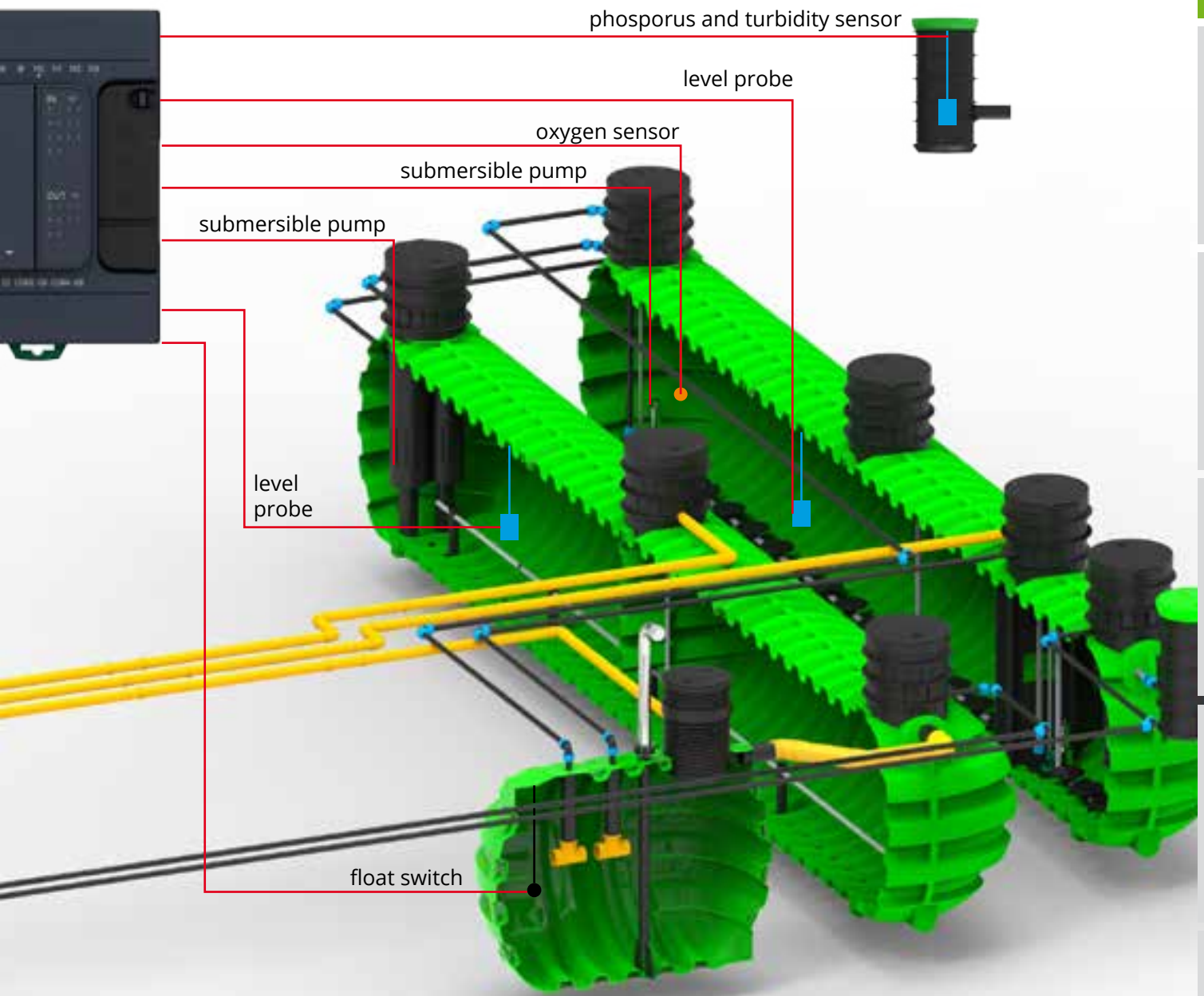

Water tanks

Waste water treatment plants

Septic tanks

Grease separators

Oil separators

Shafts

Pumping stations



**Control unit**

- The control unit provides the following functions:
- monitoring the operation of the treatment plant
  - touch screen operation
  - transmitting data to the RoCloud control server
  - network connection with a network cable or via WiFi wireless connection

**RoCloud control server**

- RoCloud provides the following features:
- storing treatment plant data
  - notifying users of malfunctions via e-mail

**APP RoWeb**

- The RoWeb app allows the user to:
- RoWeb is supported by Android/iOS operating systems, as well as home computers Windows or Mac
  - monitoring of all operating parameters of the treatment plant
  - notification of malfunctions via push messages
  - one-click mud and service pumping order
  - archive logs of maintenance and servicing



**Control center**



RoWeb control unit allows the operation of Waste water treatment plant (WWTP) up to 40 population units (PU). Control of the WWTP is possible as a local operation - without network connection, or connected with network allowing user to manage and monitor WWTP.

Network connection with the control unit is sending data to the control center, which can be directly accessible with your smart phone. Management takes place via the built-in touch screen and the mobile app available on Google Play.

The control unit have two levels of acces. The first is for the user (owner of the WWTP) and the second for the servicer or managers.



The mobile app is available on Google Play in two languages [Slovenian and English]. Users can install it by searching for the keyword RoWeb or simply by scanning the QR code below.

The first time you start the application. Enter the serial number of the device and select save. Between the menus of the application, the user scrolls to the left or right to acces all the menus.

The second screen below shows the status of WWTP in the NORMAL operating mode. User can click on the button to access the instructions of operation. By clicking on the button info the user can activate the HOLIDAY mode. By clicking the same button again the NORMAL MODE is switched on again.

On the third screen below displays information of the WWTP operation.

Screen above shows the user personal data and the e-mail address of the service company. Screen below shows the current alarm, and the user has the option to turn on notifications. Below the notifications tabs, there is shown history of the last 100 alarms, which cannot be deleted and is also permanently stored in our control center.





Water tanks

Waste water treatment plants

Septic tanks

Grease separators

Oil separators

Shafts

Pumping stations



The user settings menu allows you to choose between INFO, ALARMS, SERVICE, PROGRAM, ANALYSIS.

The basic picture shows all the most important elements of the operation of the treatment plant such as serial number, operating mode (eg normal or holiday), operating schedule (cycles), adequacy of operation and possible malfunctions and user settings.

The **LAB DATA** menu allows you to display the last laboratory analysis of the WWTP. Laboratory analyzes are entered via the service settings of the mobile application or directly from the operator control center.

The **INFO** menu shows the operating hours of the WWTP, the number of hours until depletion, the operating hours of the compressor and the number of hours until the compressor is serviced.

The **SERVICE** menu allows manual activation of all treatment plant actuators. It is intended to test the operation of an individual actuator.

The **ABOUT** menu allows you to view the system data of the WWTP like date, time, IP address, serial number, device name, program version and operating time.

The **ALARM** menu shows WARNINGS and ERRORS.



RoWeb SLO



RoWeb EN



award for inovation

Gospodarska  
zbornica  
Slovenije



ZRMK

Grodbeni Inštitut ZRMK, d.o.o.  
Building and Civil Engineering Institute ZRMK

# RoEco

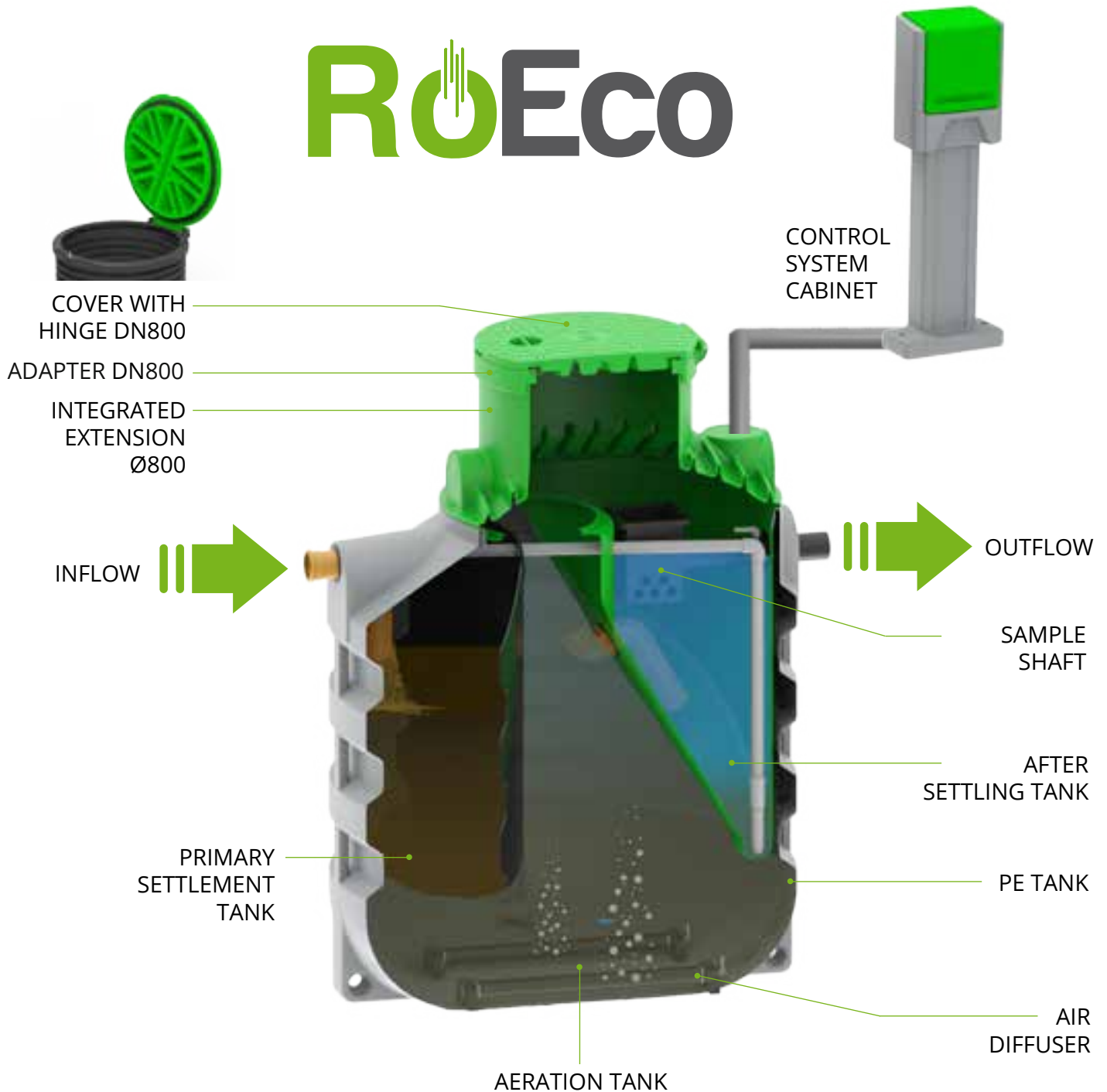

## FLOW TECHNOLOGY

The RoEco biological treatment plant purifies water in 3 steps:

1 PRIMARY settler - water from the household flows into the primary settler in which floating non-degradable particles are retained

2 AERATION - water flows into the aeration chamber through an opening in the bottom of the primary settler. At the bottom of the treatment plant, pipe diffusers are installed through which we supply air, which enables the biological cleaning process.

3 CLEANER - over the overflow elbow, water flows from the aerator to the clarifier, where sedimentation follows. With the help of an air pump, the sediments are pumped back into the primary settler.

Using flow technology, wastewater is treated in accordance with legal limit values. All components of the treatment plant are made in Slovenia from high quality materials.

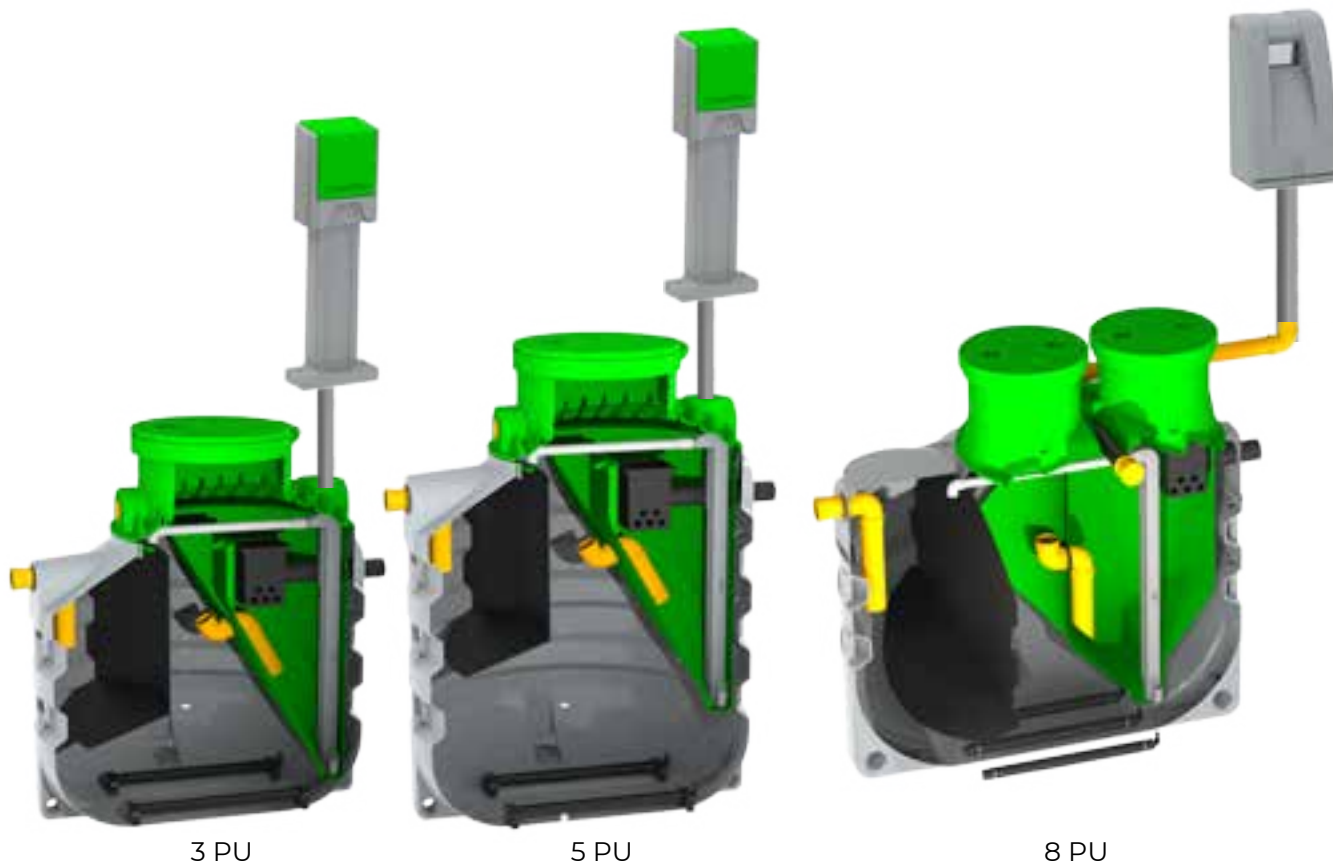

3 PU

5 PU

8 PU

PU	3	5	8
Code	7200668100	7200663800	7200663810
Max. day inflow [l/dan]	450	700	1200
Volume [L]	3200	4000	6000
Dimension A x B [mm]	Ø1800 x 2000	Ø1800 x 2350	Ø2300 x 2300
Diameter of inspection opening	1x DN800	1x DN800	2x DN600
Diameter of inflow/outflow pipe	DN 110	DN 110	DN 125
Airflow volume (compressor) [l/min]	80	80	150
Power consumption (compressor) [W]	58	58	170
Sound level [dB]	36	36	46
Control system cabinet	P4	P4	P6 upper part
Control unit	RoControl RE	RoControl RE	RoControl RE
Sample shaft	20 L	20 L	20 L

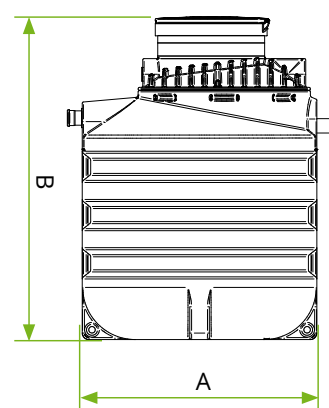

Water tanks

Waste water treatment plants

Septic tanks

Grease separators

Oil separators

Shafts

Pumping stations

### COVER DN 600 WITH TELESCOPIC EXTENSION

The Roterra tank cover with seal and hinged opening ensures effective water tightness. The load capacity of the PE DN 600 cover is up to 200 kg.

### DN 600 HINGED COVER

The height of the extension can be adjusted to the terrain.

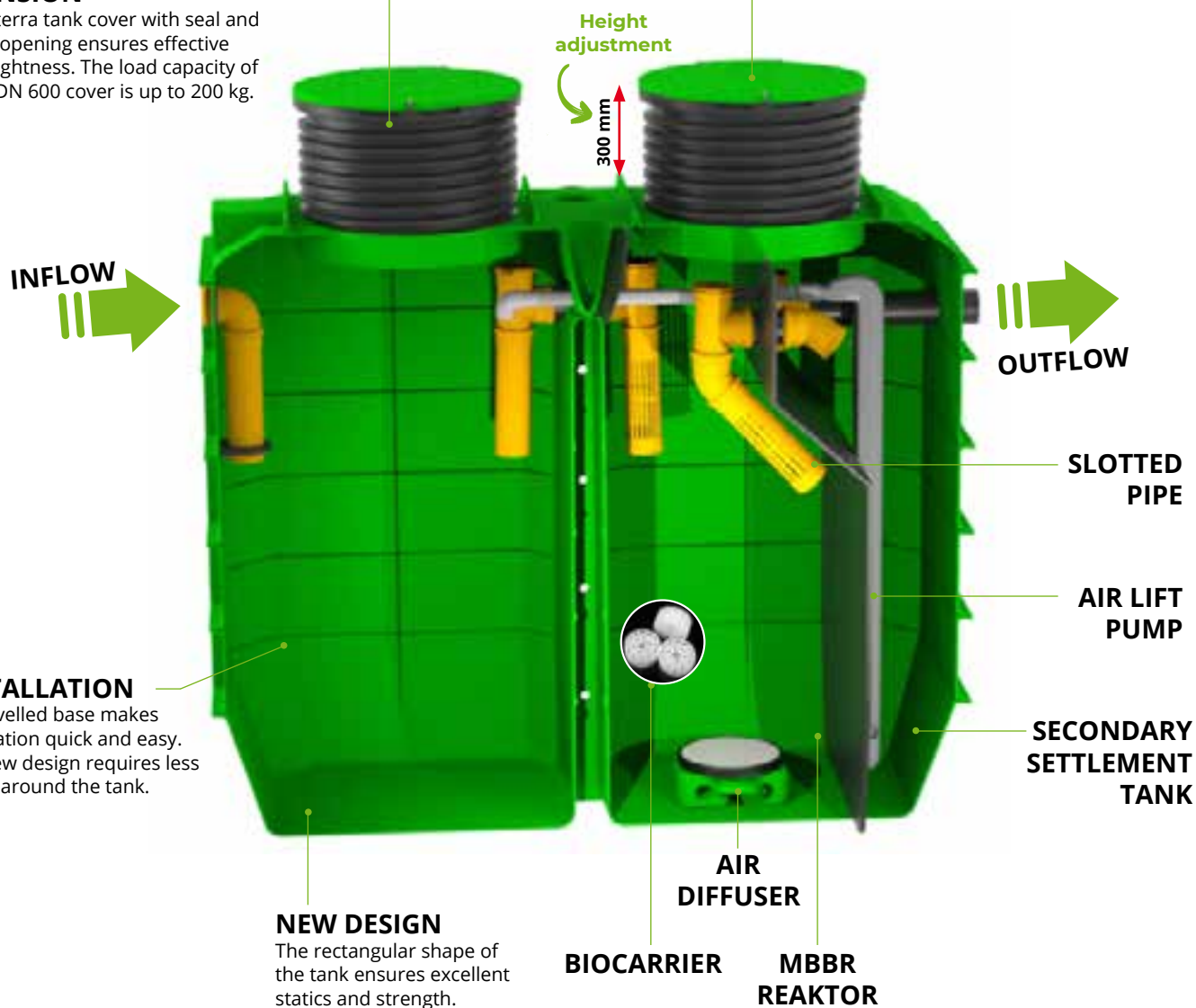

### INSTALLATION

The levelled base makes installation quick and easy. The new design requires less gravel around the tank.

### NEW DESIGN

The rectangular shape of the tank ensures excellent statics and strength.

Product	Volume [L]	Max day inflow	Code	Dimensions A x B x C [mm]	Cover [mm]
4 PU EcoBlue	4.000 L	0,9 m <sup>3</sup>	7200079810	2330 x 1175 x 1950-2280	Ø600
8 PU EcoBlue	6.000 L	1,5 m <sup>3</sup>	7200079770	2450 x 1350 x 2520-2720	2x Ø600

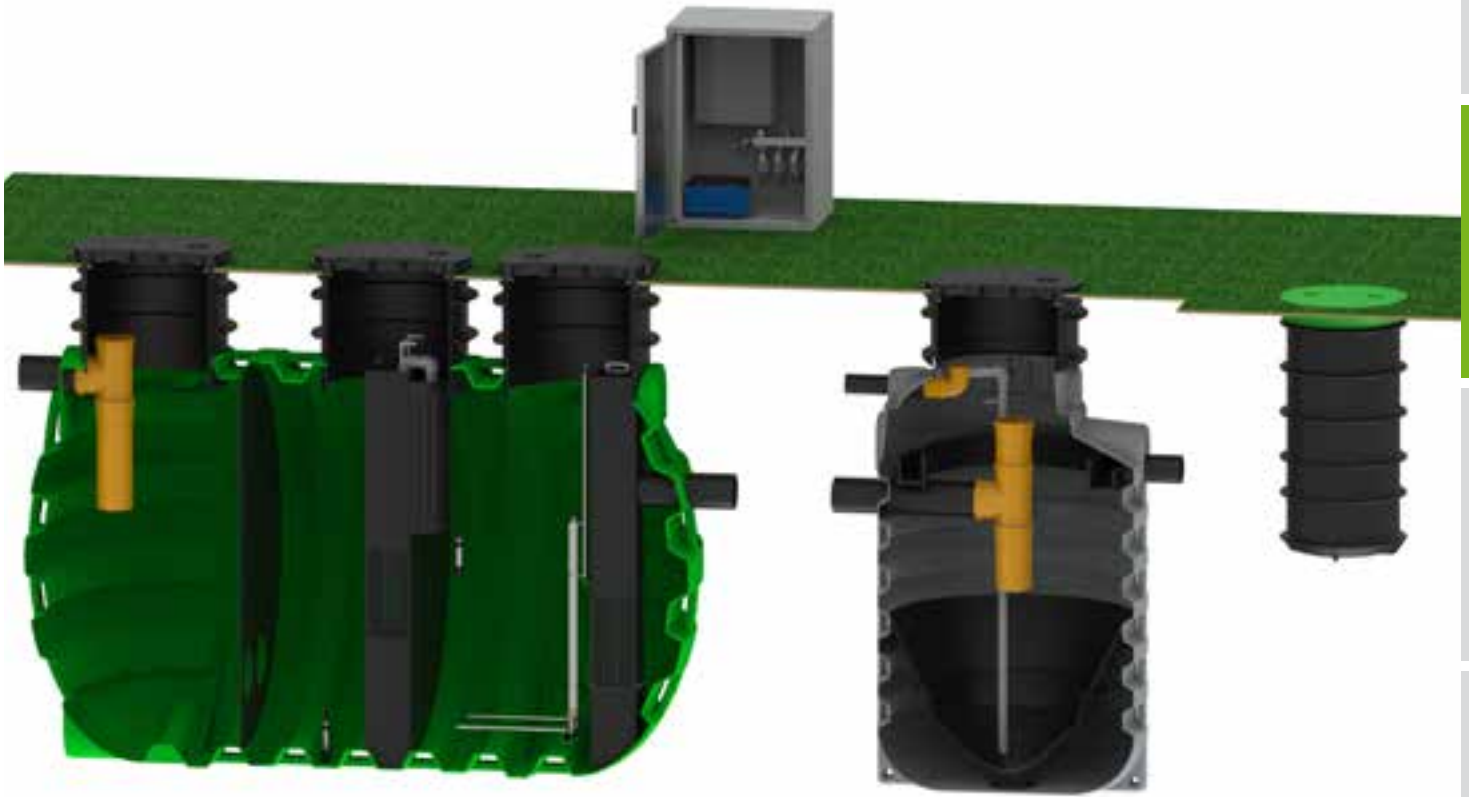

Water tanks

Waste water treatment plants

Septic tanks

We produce treatment plants with MBBR technology for larger facilities up to a capacity of 2000 PE.

Operation and technological design are adjusted according to the specifics of the facility and the biological load of the inflow.

Denitrification, nitrification and anaerobic zones can be arranged inside the MBBR reactor.

Grease separators

Oil separators

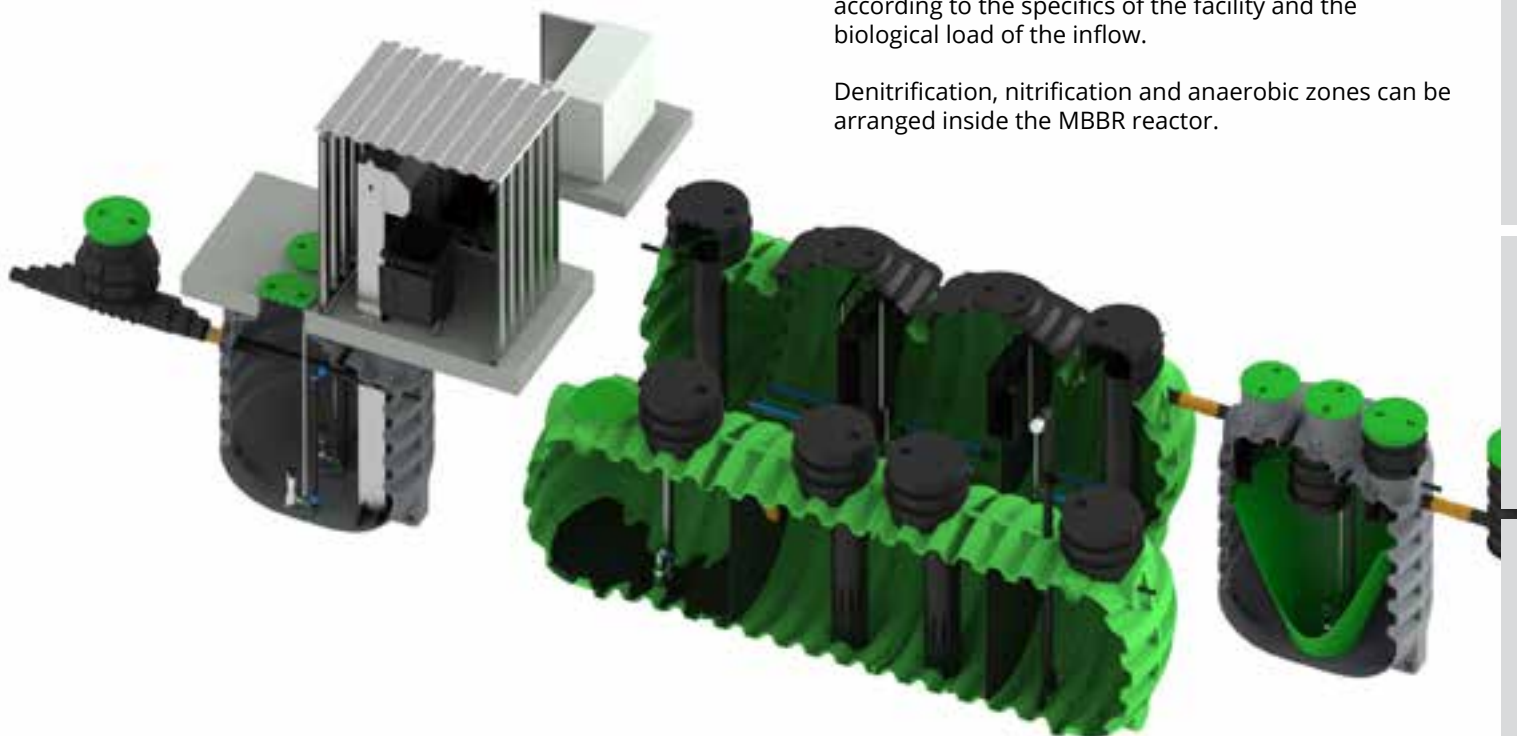

Shafts

Pumping stations

# RoMem

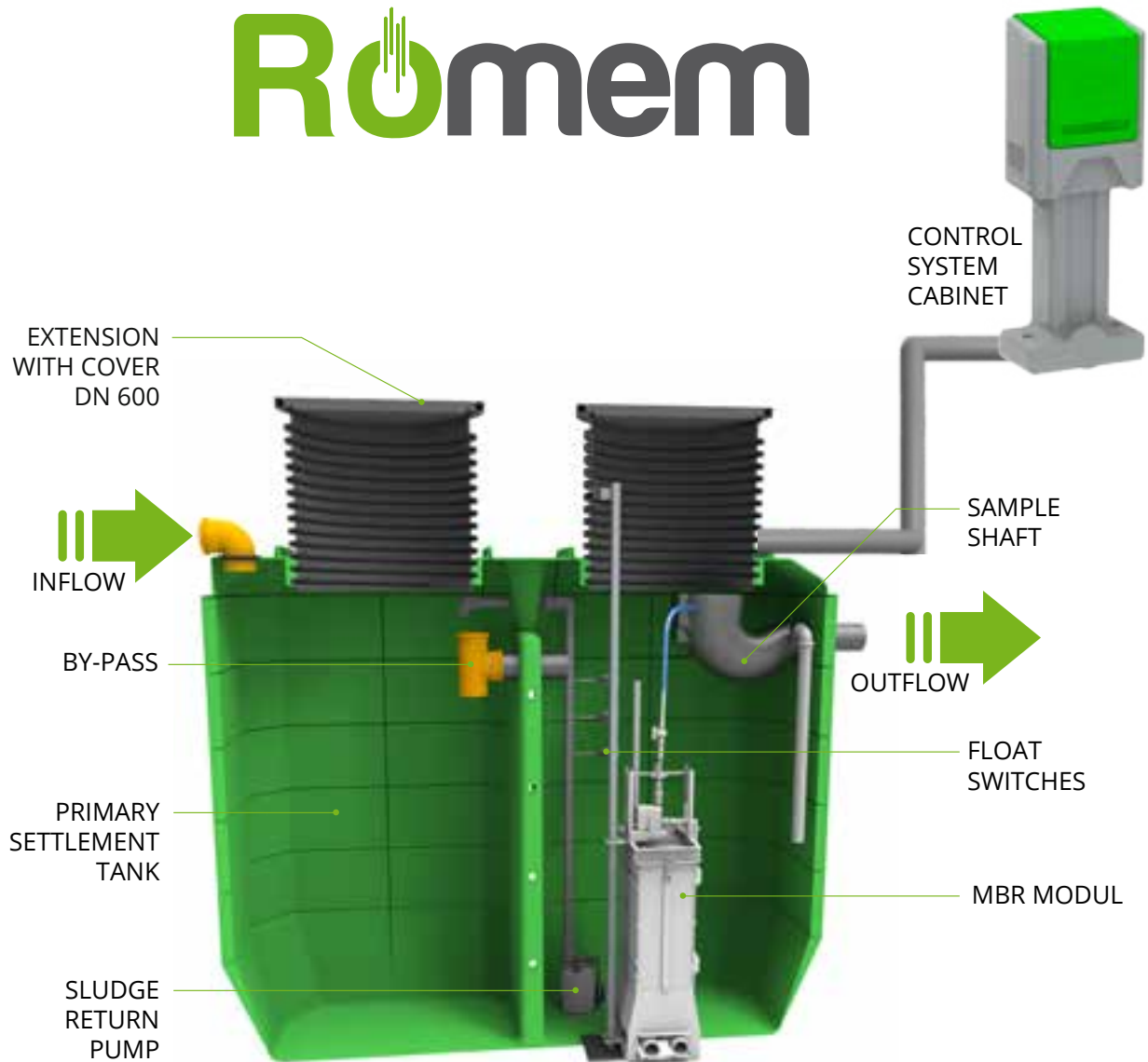

## MBR TECHNOLOGY:

A membrane bioreactor (MBR) is a waste water treatment process that combines membrane filtration and biological treatment. This innovative technology offers a number of advantages over the conventional sludge activation process, such as higher biomass concentration and elimination of the need for additional treatment.

RoMem purifies waste water into clean, high-quality water that can be discharged into nature, or used for irrigation and some sanitation purposes.

The MBR module consists of polypropylene panels with a polymer membrane on each side and a frame. The membranes are installed in a RoBox polyethylene tank. In addition to filtration, aeration takes place in the tank. The membranes are cleaned once or twice a year.

The elevated biomass concentration in the MBR process allows for very efficient removal of both soluble and insoluble particles of biodegradable materials at high loading rates. Extended retention times ensure that the waste water is fully nitrified even in very cold weather.

In wastewater treatment with MBR technology, the biological treatment process is combined with a filtration unit (membrane filter). The membrane filter consists of a large number of membranes through which water is separated from biomass.

With MBR technology we achieve better quality of purified water at the outlet.

### ADVANTAGES

- higher degree of purification
- possibility to reuse purified water (for watering, rinsing, etc....)
- possibility of industrial water treatment
- minimized unpleasant odor
- it also works reliably in intermittent inflows



PU	4	6
Code	7200088800	7200088810
Max. day inflow [l/dan]	600	900
Volume [L]	4000	6000
Dimension A x B [mm]	2330 x 1175 x 2440	2450 x 1350 x 2775
Diameter of inspection opening	DN600	DN600
Diameter of inflow/outflow pipe	DN110	DN110
Airflow volume (compresor) [l/min]	120	120
Power consumption (compresor) [W]	130	130
Sound level [dB]	48	48
Control system cabinet	P5	P5
Control unit	MS	MS
Sample shaft	5 L	5 L

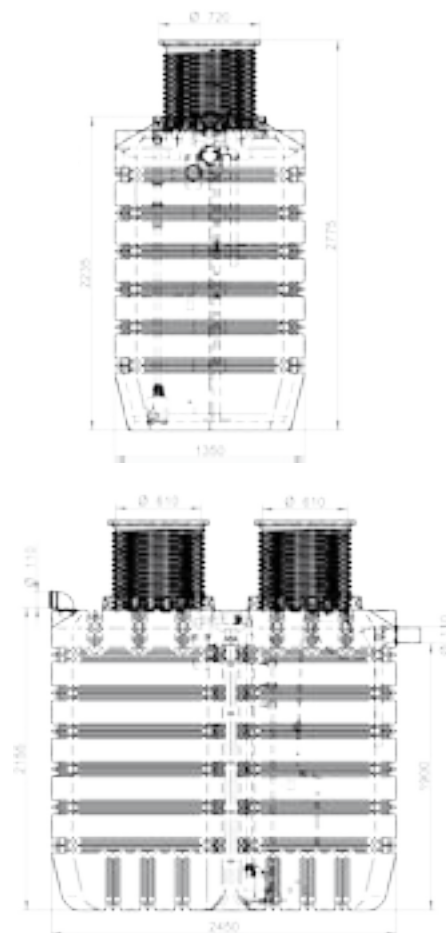

Water tanks

Waste water treatment plants

Septic tanks

Grease separators

Oil separators

Shafts

Pumping stations

# EkoFloat

EkoFloat industrial water systems operate on the principle of dissolved air flotation system (DAF), which is designed to remove common suspended solids, fats, oils and greases.



## Advantages

- the possibility of renting a pilot device
- own development center
- technologically advanced design
- package solutions
- many years of experience in the field of sewage treatment plants

## Fields of application

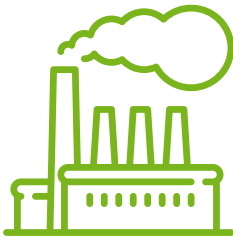

### Industry

- Slaughterhouses
- Dairies
- Breweries
- Distilleries
- Fish processing
- Bakeries
- Food processing
- Refineries
- Industrial chemical cleaning
- Textile industry
- Paper industry
- Plastics industry



### Communal waters

- Primary treatment before biological
- Sludge cleaning
- Thickening of sludge
- Tertiary treatment
- Surface water treatment
- Gray water treatment (hotels)
- Drinking water

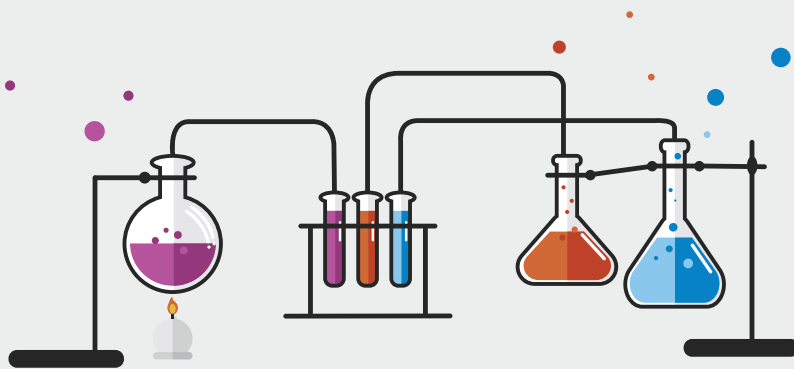

### PILOT INSTALLATIONS

We also offer the possibility to rent pilot systems for industrial water. You can pre-test the pilot plants and check the performance of the systems for your business.





**INDUSTRIAL TREATMENT PLANTS**

## Optimized DAF Clarifier

The EkoFloat-E is a very compact circular DAF clarifier designed specifically for smaller application. The Unit is prefabricated into transportable sections and minimizes installation and maintenance costs. All wetted parts are in stainless steel or chemical resistant materials.

EkoFloat-E is available in 11 sizes from 16 to 450 m<sup>3</sup>/h. The EkoFloat-E has few moving parts and requires minimal maintenance.

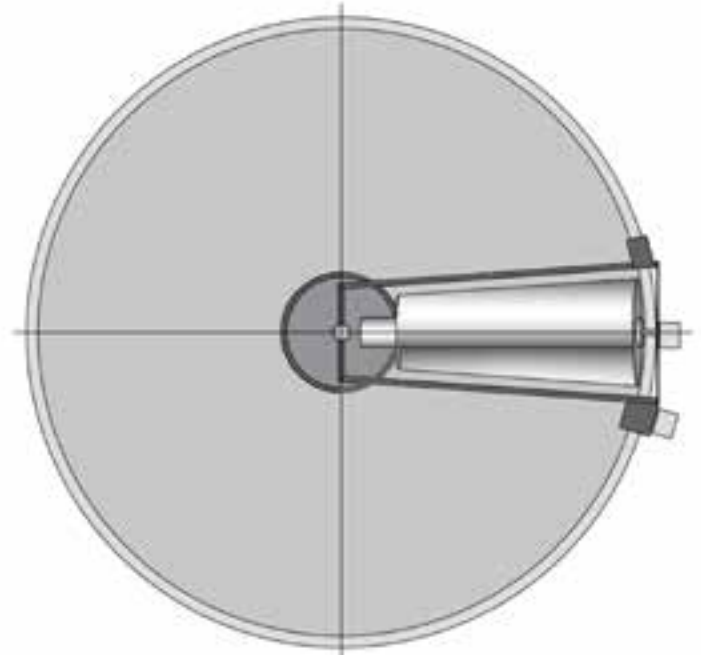

Type	Max. flow (m <sup>3</sup> /h)*	Tank ø (mm)	Tank H (mm)	Weight full of water (tons)
E 18.5	16	1850	1000/1500	3/4,3
E 25	34	2500	1000/1500	5/ 7,2
E 32	60	3200	1000/1500/2000	8/11,5/15
E 39	90	3900	1000/1500/2000	12/18/24
E 45	115	4500	1000/1500/2000	15/23/31
E 55	180	5500	1500/2000	34/46
E 61	220	6100	1500/2000	42/57
E 67	250	6700	1500/2000	51/68
E 72	300	7200	1500/2000	60/85
E 81	400	8100	1500/2000	80/96
E 90	450	9000	1500/2000	108/140

\*The maximal flow includes recycle flow and is dependent on suspended solids loading and application.

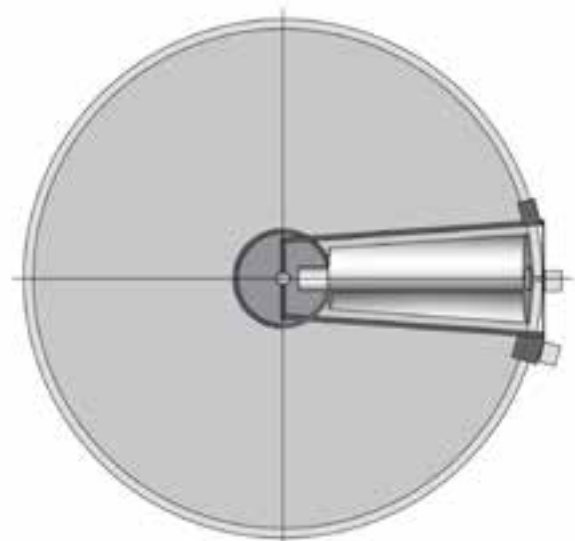
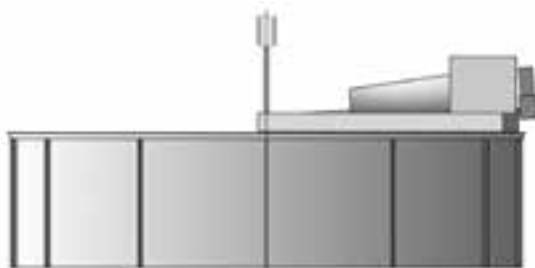

## Optimized DAF Clarifier

The EkoFloat-R advanced flotation clarifier is a cost effective, continuously operating clarifier for liquids solids separation. The Unit is prefabricated into transportable sections and minimizes installation and maintenance costs. All wetted parts are in stainless steel or chemical resistant materials.

EkoFloat-R is available in 19 sizes from 16 to 2700 m<sup>3</sup>/h. The open tank has an approximate depth of around 400mm. Water is processed from inlet to outlet in two minutes.



Type	Max. flow (m <sup>3</sup> /h)*	Tank ø (mm)	Tank H (mm)	Weight full of water (tons)
R 18.5	16	1850	755	2,2
R 25	34	2500	850	4,4
R 32	61	3200	850	6,9
R 39	92	3900	900	9,9
R 45	123	4500	950	12,7
R 55	185	5500	950	19,1
R 61	228	6100	950	23,3
R 67	275	6700	950	27,7
R 72	319	7200	950	33
R 81	405	8100	950	40,9
R 90	513	9000	950	49,1
R 100	632	10000	950	63
R 110	765	11000	950	75,4
R 122	942	12200	950	91,2
R 134	1135	13400	950	109
R 148	1387	14800	950	135
R 167	1785	16700	1050	185
R 189	2160	18900	1050	245
R 213	2700	21300	1050	300

\*The maximal flow includes recycle flow and is dependent on suspended solids loading and application.

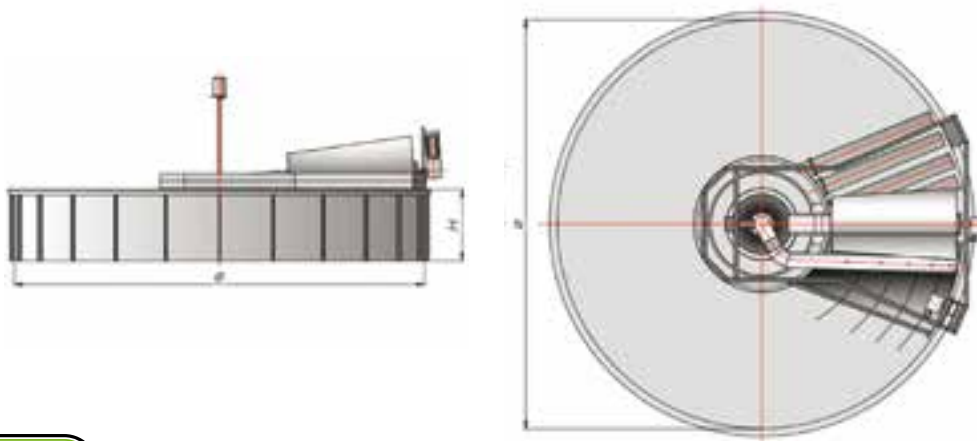

## Optimized Horizontal DAF Clarifier

The EkoFloat-H is a re-designed state of the art high rate dissolved air flotation (DAF) clarifier which, in a break from traditional clarifier, use "U-Shaped-Separators" and provide maximum flowrate per surface area of footprint. The Unit is prefabricated into transportable sections and minimizes installation and maintenance costs. All wetted parts are in stainless steel or chemical resistant materials.

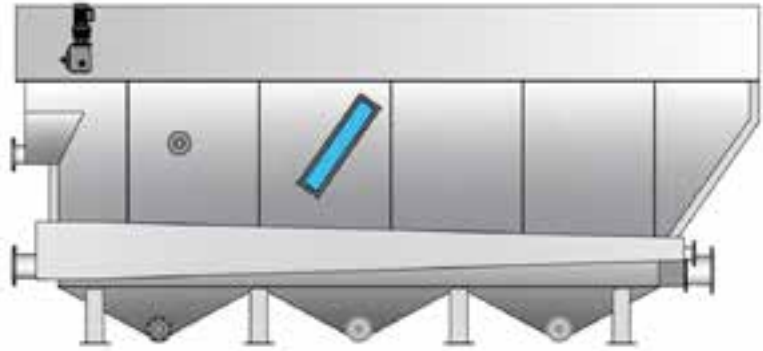

Type	Max. flow (m <sup>3</sup> /h)*	A (mm)	B (mm)	C (mm)	Weight full of water (tons)
H 25	25	2000	2800	1500	2,5
H 50	50	2800	2800	1500	4,5
H 75	75	2900	2800	2000	8
H 100	100	3000	2800	2500	11
H 150	150	3600	2800	2500	14
H 200	200	4600	2800	2500	18
H 250	250	5200	3000	2500	22
H 312	312	6600	3000	2500	28
H 375	375	7600	3000	2500	35
H 500	500	9600	3000	2500	44
H 625	625	9800	3000	2500	52
H 625 - 2	625	9300	3300	4600	55
H 750	750	10400	3400	3300	66
H 750 - 2	750	9100	3300	4600	67
H 1000 - 2	1000	11100	3800	4600	116
H 1250 - 2	1250	12700	3800	5000	165

\*The maximal flow includes recycle flow and is dependent on suspended solids loading and application.

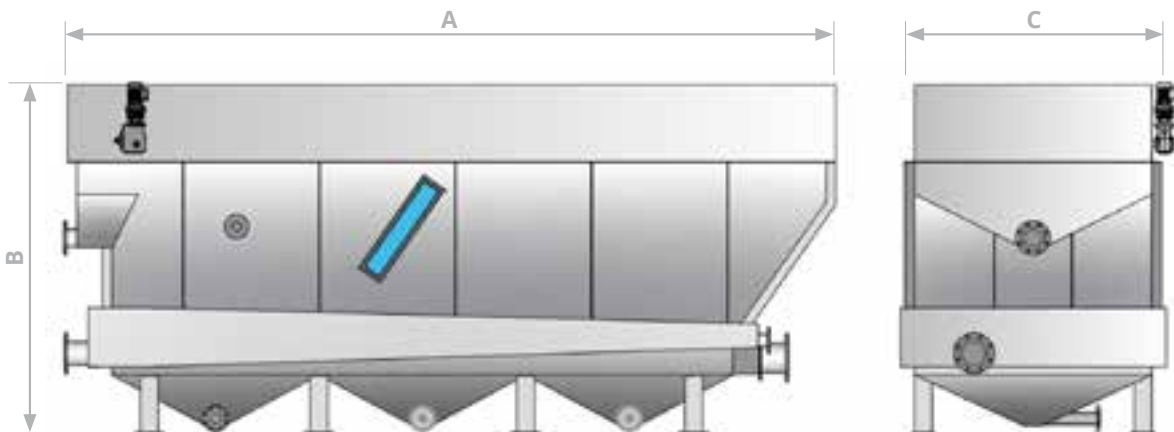

## Optimized Vertical DAF Clarifier

The EkoFloat-V is a state of the art high rate dissolved air flotation clarifier (DAF) which, in a break from traditional clarifier, use "U-Shaped-Separators" and provide maximum flowrate per surface area of footprint. The Unit is prefabricated into transportable sections and minimizes installation and maintenance costs. All wetted parts are in stainless steel or chemical resistant materials.

EkoFloat-V is available in 17 sizes from 12,5 to 1250 m<sup>3</sup>/h. The EkoFloat-V is a new optimized generation of vertical DAF clarifier, optimized, designed and manufactured by Ekoling d.o.o.

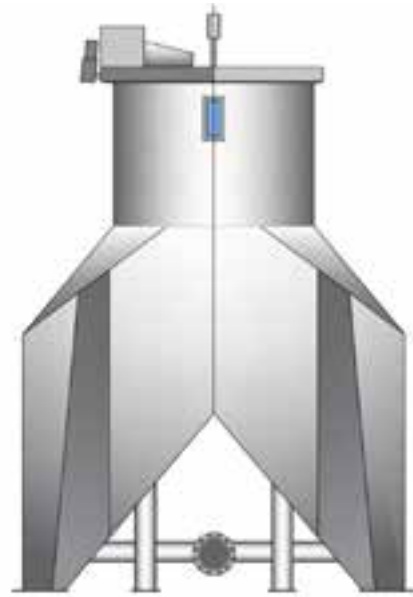

Type	Max. flow (m <sup>3</sup> /h)*	A ø (mm)	B (mm)	C (mm)	D (mm)	Weight full of water (tons)
Ø V 75	75	2250	4250	-	-	17
Ø V 100	100	2250	5250	-	-	22
Ø V 150	150	2250	6250	-	-	27
Ø V 200	200	2250	7250	-	-	32
Ø V 250	250	2250	8250	-	-	38
Ø V 375	375	3000	9000	-	-	65
# V 12,5	12,5	-	3100	1500	550	1,9
# V 25	25	-	3100	1500	1000	3,2
# V 50	50	-	4100	1500	1000	5,1
# V 75	75	-	4100	1500	1500	7,5
# V 250-2	250	2100	5350	4300	2300	25
# V 375-2	375	2100	6900	4300	2300	35
# V 500-2	500	2100	8100	4300	2300	60
# V 500-4	500	4000	5350	4350	-	80
# V 750-4	750	4000	6600	4350	-	110
# V 1000-4	1000	4000	7650	4350	-	150
# V 1250-4	1250	4000	8800	4350	-	200

\*The maximal flow includes recycle flow and is dependent on suspended solids loading and application.

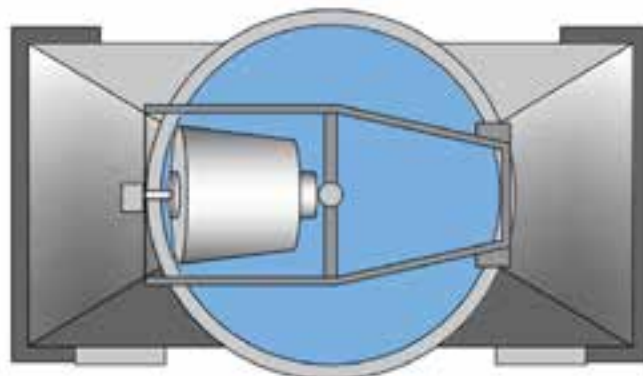

Water tanks

Waste water treatment plants

Septic tanks

Grease separators

Oil separators

Shafts

Pumping stations

Water tanks



Waste water treatment plants

Septic tanks

Grease separators

Oil separators

Shafts

Pumping stations

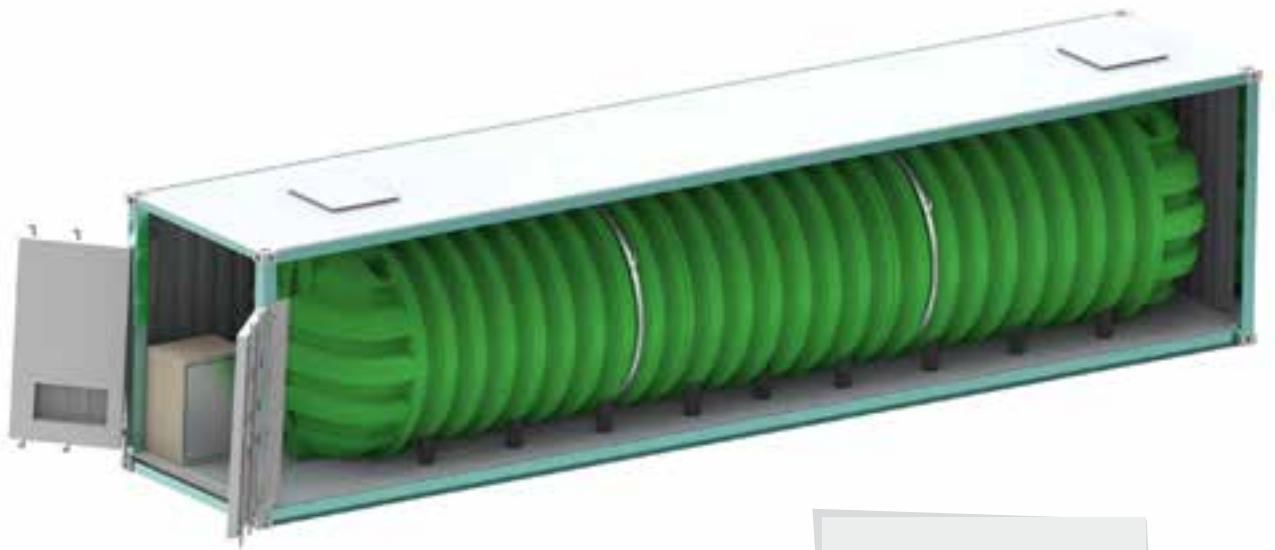
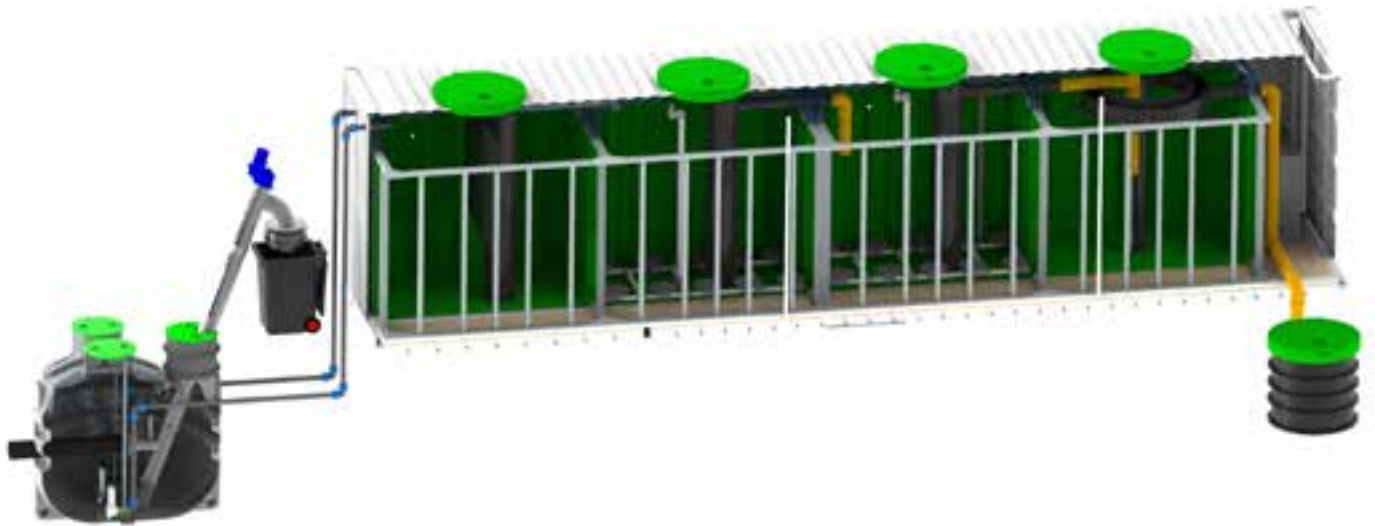

COMING SOON



LOGISTIC CENTER



INDUSTRIAL HALL



INDUSTRIAL HALL



FUEL STATION



MOUNTAIN HOUSE



ELECTRIC POWER PLANT



SHOPPING CENTER

Water tanks

Waste water treatment plants

Septic tanks

Grease separators

Oil separators

Shafts

Pumping stations



• Inlet pipe size DN110 till DN160

Types:

- two-chamber
- three-chamber

Septic tanks are built as an impermeable collector for municipal wastewater, from which municipal wastewater is taken for treatment or treatment at a municipal wastewater treatment plant. Exceptionally, municipal wastewater may be collected in a non-flowing septic tank only in areas where the treatment of municipal wastewater in the WWTP is not technically feasible due to special circumstances such as special geographical conditions or sparsely populated buildings.



Volume [L]	2-chamber (code)	3-chamber (code)	A (d) [mm]	B (š) [mm]	C (v-min) [mm]	C (v-max) [mm]	D (H inflow) [mm]	DN (inflow/inflow pipe) [mm]
1.000	7500063610	-	1580	1060	1000	1380	850	110
2.200	7500067610	-	1840	1400	1600	2100	1250	110
2.600	7500067380	-	2150	1400	1600	2100	1250	110
3.000	7500063600	-	2400	1400	1600	2100	1250	110
3.500	7500063300	-	2080	1800	2050	2550	1600	110
5.000	7500062390	7500063620	2450	1800	2050	2550	1600	110
6.000	7500063280	7500063290	2820	1800	2050	2550	1600	110
8.000	7500062550	7500062560	2680	2300	2350	2850	2100	160
10.000	7500069031	7500069032	3040	2300	2350	2850	2100	160
12.000	7500062510	7500062530	3760	2300	2350	2850	2100	160
16.000	7500066190	7500066200	4840	2300	2350	2850	2100	160

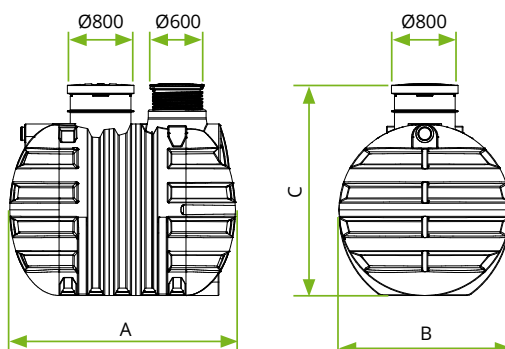



Water tanks

Waste water treatment plants

Septic tanks

Grease separators

Oil separators

Shafts

Pumping stations

Volume [L]	2-chamber (code)	3-chamber (code)	A (d) [mm]	B (š) [mm]	C (v-min) [mm]	C (v-max) [mm]	D (H inflow) [mm]	DN (inflow/inflow pipe) [mm]
20.000	7500062590	7500062690	4540	2300	2350	2850	2050	160
25.000	7500067620	7500067640	5720	2300	2350	2850	2050	160
30.000	7500065000	7500065001	6550	2425	2700	3000	2400	160
35.000	7500065010	7500065011	7530	2425	2700	3000	2400	160
40.000	7500065020	7500065021	8510	2425	2700	3000	2400	160
45.000	7500065030	7500065031	9870	2425	2700	3000	2400	160
50.000	7500065040	7500065041	10850	2425	2700	3000	2400	160
55.000	7500065050	7500065051	11500	2425	2700	3000	2400	160
60.000	7500065060	7500065061	12480	2425	2700	3000	2400	160
65.000	7500065070	7500065071	13460	2425	2700	3000	2400	160

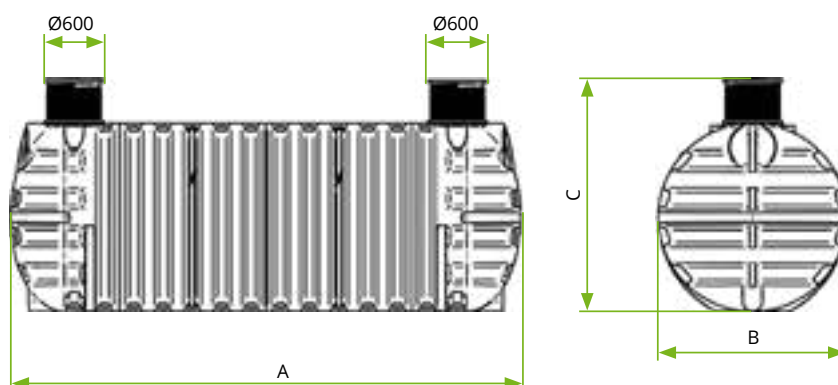

In businesses which produce wastewater containing fat or grease, grease separators must be installed in accordance with EN 1825 and DIN 4040-100 in order to prevent damage to sewer pipes and wastewater treatment facilities. They reduce incidents of blocked drains from kitchen, improve the performance of septic tanks, prevent contamination of small sewage treatment plants.

## Installation

The grease separator should be installed close to the source of contamination, inside or outside the building.

Underground grease separator should be located close to the building in areas where release of strong and aggressive odors will not pose a problem and where it is possible to access the separator with the disposal hose of the disposal truck.

The inlet level must be located below the frost level. The grease separator has to be opened for emptying and cleaning.

## Material

ROTO grease separators are made from environmentally friendly material (PE). They are very durable, lightweight and resistant against various chemical substances used in kitchen.

## Advantages

- produced in EU
- in accordance with standard BS EN 1825-1
- made from durable, hard polyethylene (LLDPE)
- has a long lifetime
- 100% recyclable after use
- waterproof
- quick and easy installation (light weight, no need for a crane)
- easy maintenance
- low operating costs



### Determine the size

$$NG = Q_s * f_d * f_t * f_r * f_m$$

**Q<sub>s</sub>** - the amount of waste water in l/s

**f<sub>d</sub>** - density of grease (if it is greater or lesser than 0.94 g/cm<sup>3</sup>)

**f<sub>t</sub>** - temperature factor (if higher than 50 °C, is increased)

**f<sub>r</sub>** - detergents factor

**f<sub>m</sub>** - increased grease factor

### COVER WITH HINGE

The cover with gasket and hinged opening ensures effective water tightness.

### INFLOW

### TELESCOPIC EXTENSION

The telescopic extension is shaped like a screw. This mode allows quick and easy adjustment of the height when digging. The dimensions of the extension are Ø600 x 400 mm.

### OUTFLOW

### MUD COLLECTOR

In a sludge settling tank, the flow of the wastewater is moderated, so the heavier particles settle to the bottom.

### GREASE

In the grease separator oils and fats are retained at the surface due to the difference in the density of fluids.

### DIVIDING WALL

### WATER

Purified water exits the grease separator through knee pipe.

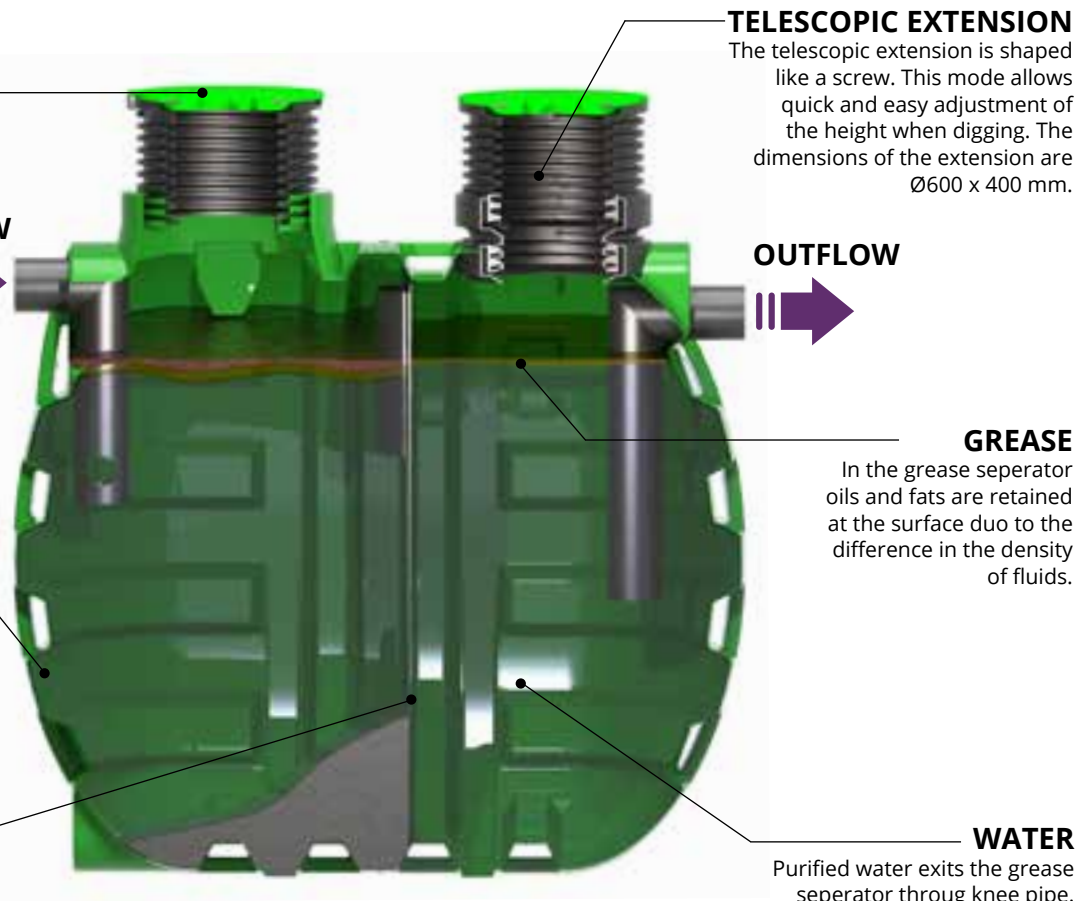

### VERTICAL SHAPE

Vertical shape of the grease separator Rogre allows easy handling of the tank on site and easy installation.

### INSPECTION OPENING

Cover is made from strong and durable polyethylene and designed to be a tight fit.

### ADAPTER

INFLOW

OUTFLOW

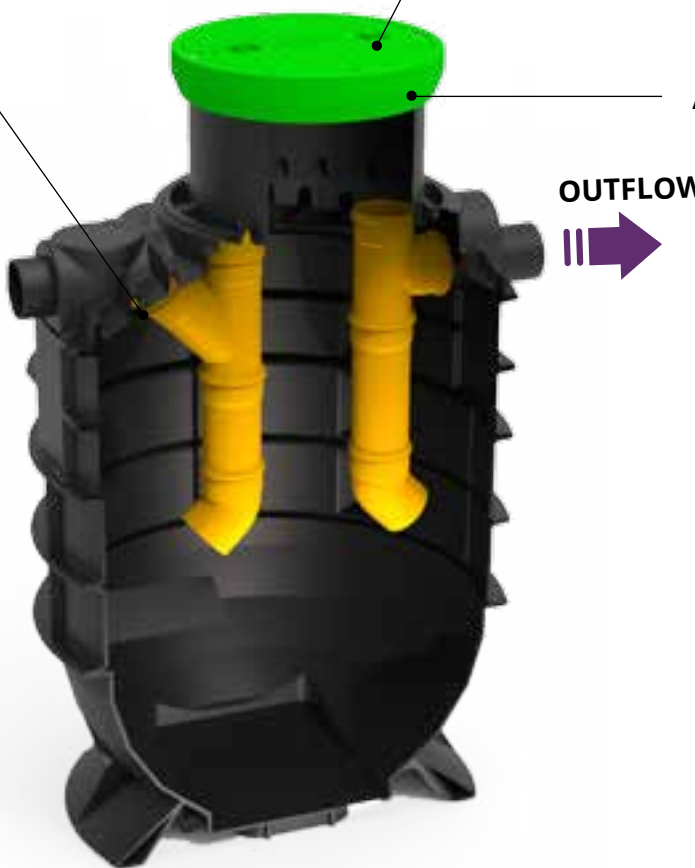
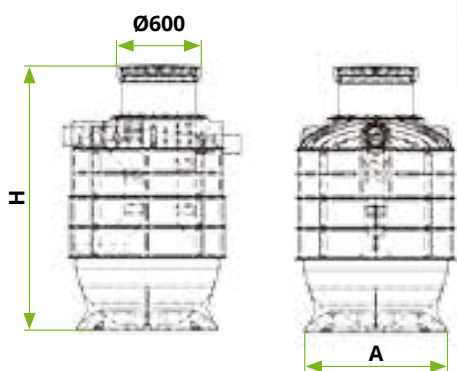

Volume [L]	NG [l/s]	Code	Dimensions A x B x C [mm]	Pipe DN [mm]	Inspection opening [mm]
800	1	7400075400	Ø1000 x 1650	110	Ø620
1.000	2	7400075410	Ø1000 x 1900	110	Ø620
1.600	4	7400075420	Ø1200 x 2200	125 / 160	Ø620

Water tanks

Waste water treatment plants

Septic tanks

Grease separators

Oil separators

Shafts

Pumping stations



Biofett grease separator is a winner of Innovation Award of the Chamber of Commerce and Industry in Pomurje.

### VERTICAL SHAPE

Vertical design of the Biofett grease separator allows the trap to be easily installed in existing buildings.

### INSPECTION OPENING

Trapped grease can be easily removed through an opening at the top of the tank.

INFLOW



OUTFLOW



### BACTERIA DOSING STATION

Installed in front of the inlet a cabinet in which the dosing with bacteria and a peristaltic pump for pH regulation.

### INSTALLATION

The level base allows quick and easy installation.

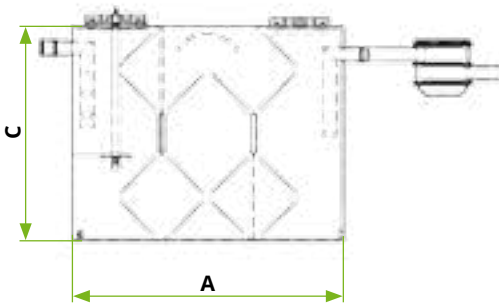

### DELOVANJE

Dirty water flows into the grease separator the initial part acts as a settling tank for sludge and solids. Here the water flow is slowed down to a point, where solids and sludge can settle or be filtered. Further, the remaining grease floats to the top due to lower density. At the inflow a dosing cabinet is installed with bacteria and peristaltic pump which regulate pH balances.

In addition NaOH is added at the inflow which regulates the acidity. After the filtration bacteria is added from the dosing station, which then break down the remaining grease particles into carbon dioxide and water. The product is tested on a grease trap NG4, where the flow rate is  $q = 4$  l/s and a daily number of meals of 400 - 700 /day. The grease separator complies with SIST EN 1825-1.



The BioFett system reduces fat and pH and is therefore designed for kindergartens, schools, restaurants over 400 meals/day, food distribution centres over 400 meals/day, nursing homes, food service centres over 400 meals/day, food service centres over 400 meals/day. The standard defines only mechanical separation of solids, grease and waste water. The ROTO Biofett grease trap has BIOLOGICAL FAT DISCLOSURE and a regulated pH regulation in the grease trap, so it achieves the required limit values of the pH parameter at outlet of the trap.

Volume [L]	NG [l/s]	Code	Dimensions A x B x C [mm]	Pipe DN [mm]	Inspection opening [mm]
2.300	4	740075690	2180 x 700 x 1725	110	Ø440, Ø410 in Ø400

### COVER WITH HINGE

Covers for grease separators come with hinged covers, that have seals installed, which make them easy to open and ensure air tight seal.

### TELESCOPIC EXTENSION

Telescopic extension for RoFett in shaped as a screw. this shapes makes it possible to adjust the height of the tank easily on the site of instalation. Dimensions of the extension are  $\varnothing 600 \times 400$  mm.

INFLOW



OUTFLOW



### REINFORCING RIBS

Reinforcing ribs on both sides provide stability of the tank and protection in the event of high water table.

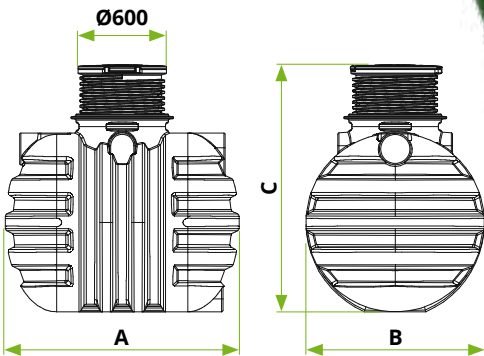

Volume [L]	NG [l/s]	Code	Dimensions A x B x C [mm]	Pipe DN [mm]	Inspection opening [mm]
500	1	7400075310	1120 x 860 x 1230	110	$\varnothing 390$
1.000	2	7400075370	1580 x 1060 x 1370	110	$\varnothing 390$
2.000	4	7400075320	1840 x 1400 x 1930	110	$\varnothing 600$
3.500	7	7400075330	2080 x 1800 x 2380	160	$\varnothing 600$
5.000	10	7400075360	2450 x 1800 x 2380	160	$\varnothing 600$
6.000	15	7400075340	2820 x 1800 x 2390	200	$\varnothing 600$
8.000	20	7400075390	2680 x 2320 x 2870	200	$\varnothing 600$
12.000	25	7400777970	3760 x 2320 x 2850	200	$\varnothing 600$

Water tanks

Waste water treatment plants

Septic tanks

Grease separators

Oil separators

Shafts

Pumping stations

**VERTICAL SHAPE**

Vertical shape of the grease separator Rogre allows easy handling of the tank on site and easy installation.

**INSPECTION OPENING**

Trapped grease can be easily removed through through the opening at the top of the tank.

**INFLOW**

**OUTFLOW**

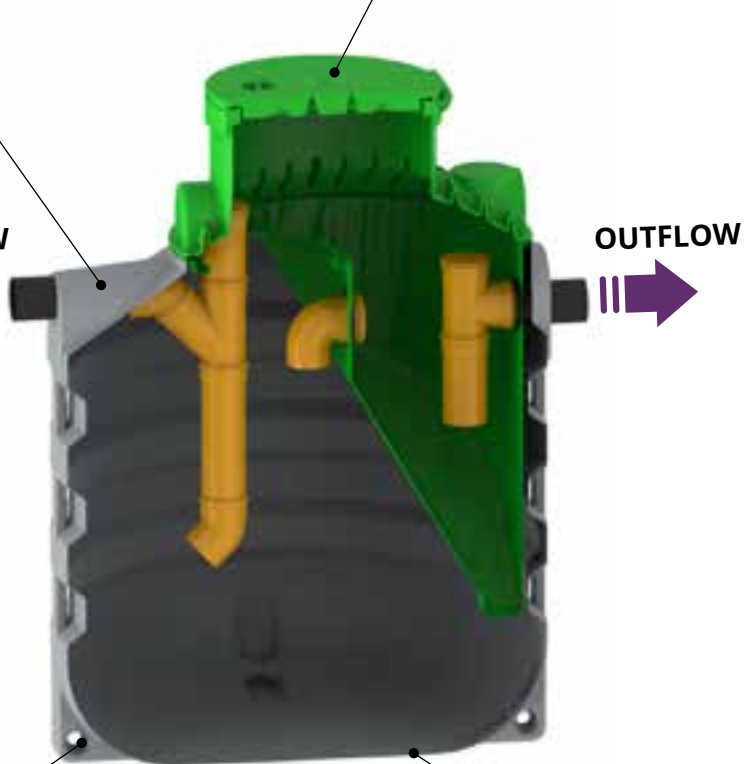
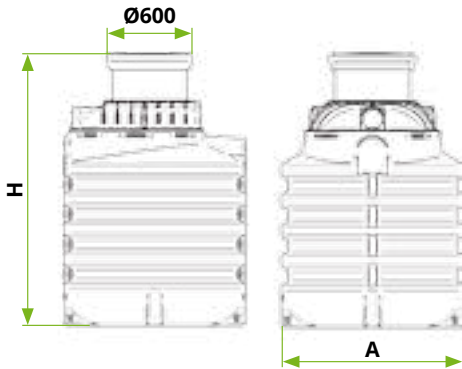

**POSITIONING LUGS**

Allows easier attachment to concrete slab in case of need anchoring due to high water table.

**INSTALLATION**

The level base allows for quick and easy installation.

Volume [L]	NG [l/s]	Code	Dimensions A x B x C [mm]	Pipe DN [mm]	Inspection opening [mm]
1.000	2	7400775310	Ø1300 x 1850	110	Ø800
2.000	4	7400775320	Ø1500 x 2000	110	Ø600
3.200	7	7400775330	Ø1800 x 2100	160	Ø800
4.000	10	7400775340	Ø1800 x 2450	160	Ø800
6.000	15	7400777960	Ø2300 x 2350	200	2x Ø600
7.500	20	7400775360	Ø2300 x 2700	200	2x Ø600

### INSPECTION OPENING

Captured fat can be easily removed through the opening at the top of the tank.

### DIMENSIONS

Due to the smaller dimensions and rectangular shape, Romast grease separators can be easily installed in existing buildings.

INFLOW

OUTFLOW

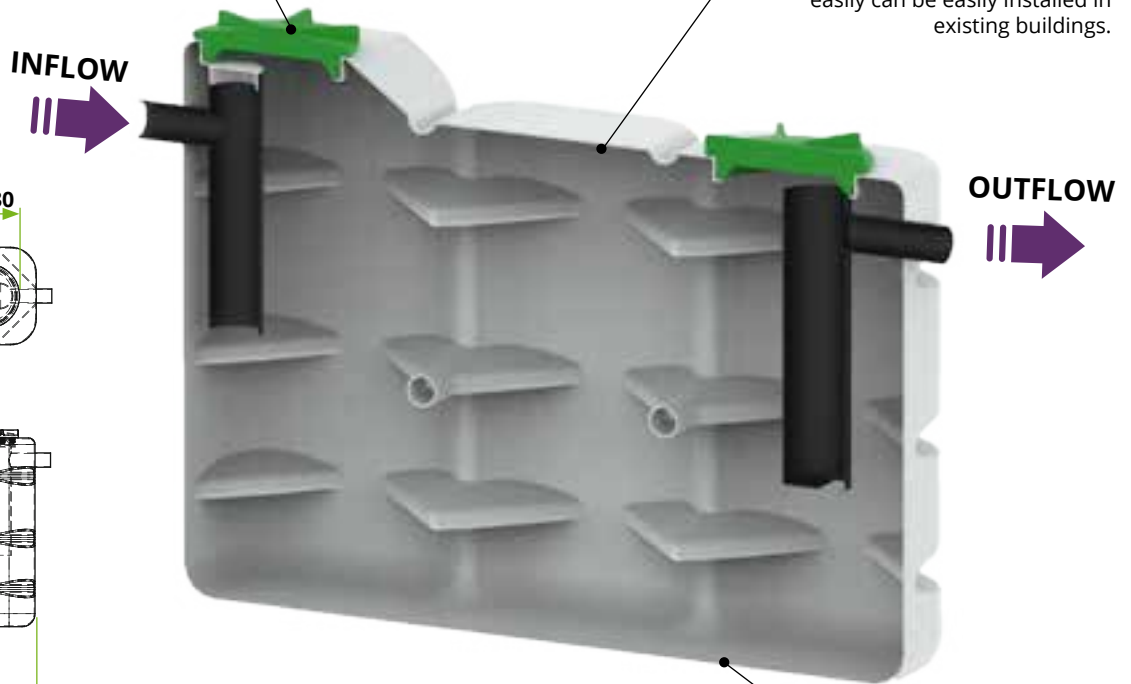
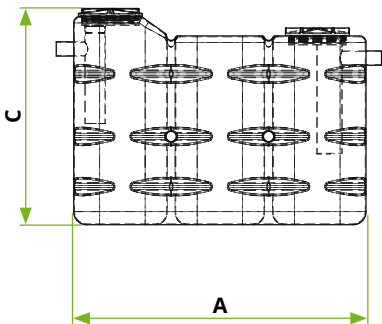
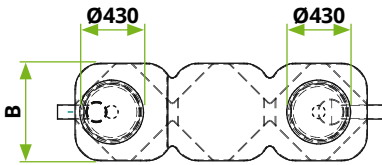

### INSTALLATION

The level base allows for fast and easy installation.

Volume [L]	NG [l/s]	Code	Dimensions A x B x C [mm]	Pipe DN [mm]	Inspection opening [mm]
100	0,25	7400778100	530 x 530 x 481	50	Ø430
250	0,5	7400777880	600 x 600 x 951	110	Ø430
500	1	7400777940	760 x 760 x 1161	110	Ø430
1.000	2	7400778580	1520 x 760 x 1161	110	2x Ø430
2.000	4	7400075290	2250 x 750 x 1161	110	2x Ø430

Water tanks

Waste water treatment plants

Septic tanks

Grease separators



Oil separators

Shafts

Pumping stations

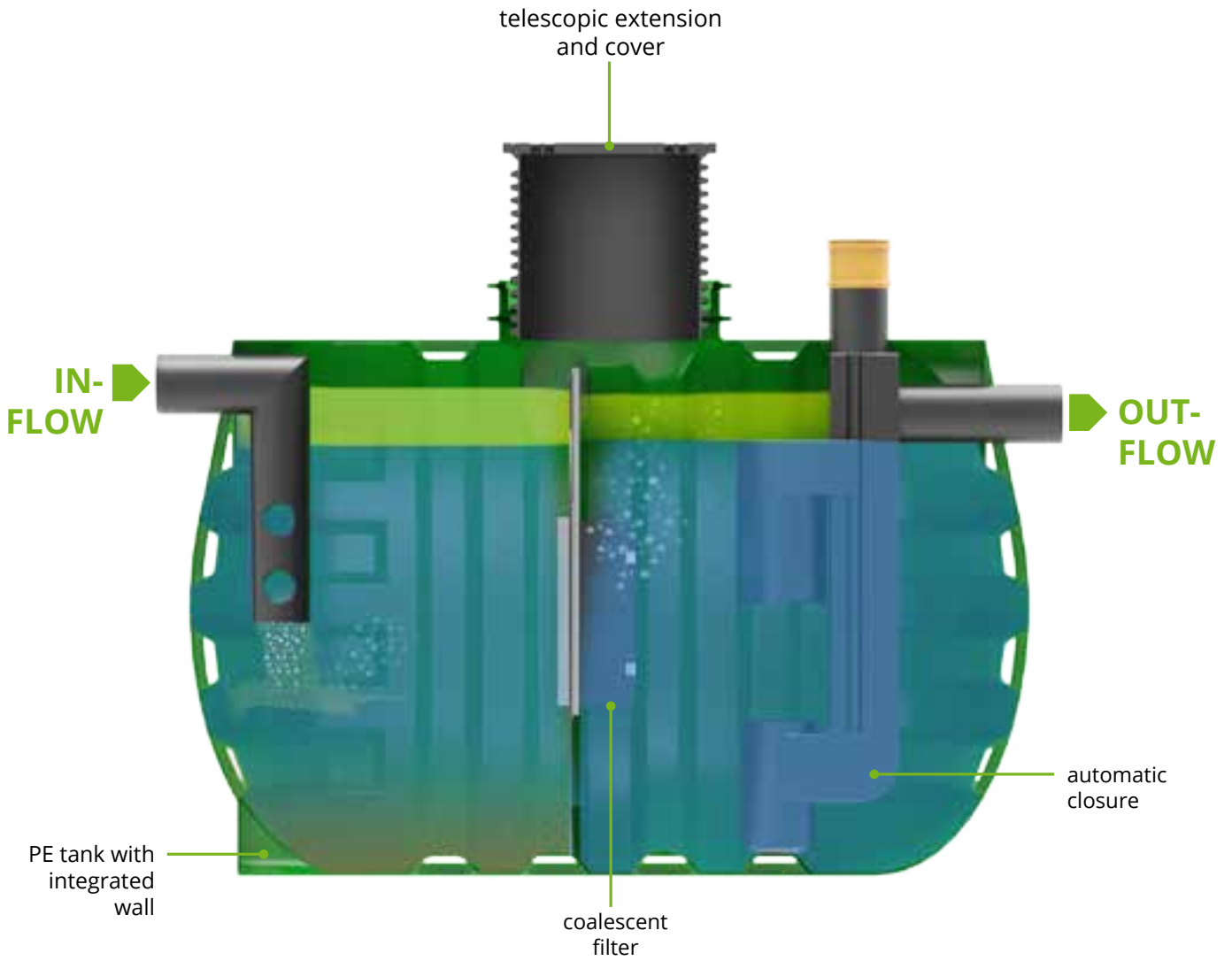
# Rosep



  
  
**Ropetrol**

  
  
**Rosep**

  
  
**Roil**

- Water tanks
- Waste water treatment plants
- Septic tanks
- Grease separators
- Oil separators**
- Shafts
- Pumping stations

Light liquid separators are designed according to EN 858 and DIN 1999-10.

## Application

Oil and coalescence separators are required where light liquids occur. This is usually at

- Petrol / Gas stations,
- Car washes,
- Vehicle workshops
- Car-parks



### Determinate **the size**

$$N_s = (Q_r + f_x * Q_s) * f_d$$

**NS** - nominal volume in l/s

**Qr** - max. flow of rainwater in l/s

**Qs** - max. flow of wastewater in l/s

**fx** - retention factor, depending on the nature of release (Table I)

**Fd** - density factor for the suitable light fluid (Table I)

## Separator classes

### class I

Designed to achieve a concentration of less than 5mg/l of oil under standard test conditions and should be used when the separator is required to remove very small oil droplets. A coalescence filter insert is installed before the drain to improve the separating effect in the separator. When the water flows through, tiny oil drops combine to form large drops which then leave the coalescence material. With oil separators a special inlet system has a plug-flow effect in the separator. This slows the flow down and distributes it in a hydraulically effective way over the separator space. The heavy materials sink to the bottom and are separated out, the light materials rise to the top and are separated off there.

### class II

Designed to achieve a concentration of less than 100mg/l oil under standard test conditions and are suitable for dealing with discharges where a lower quality requirement applies.

### Bypass

Bypass separators fully treat all flows generated by rainfall rates of up to 6.5mm/hr. (99% of all rainfall events). These separators are used on parking area when it is considered an acceptable risk not to provide full treatment for high flows, for example where the risk of a large spillage and heavy rainfall occurring at the same time is small.

#### The following cleaning steps are performed in the mud separator:

- 1) Water contaminated with oil and mud flows to the tank.
- 2) The mud is deposited at the bottom of the tank. When the water reaches the second part of the tank, the mud has already been removed.
- 3) Oil separates from water in the second part of the tank. Larger oil drops then come to the water surface because of the low density. Smaller drops combine and increase in the filter and then come to the surface.

## class I

Oil separators with installed coalescent filter are classified to the Class I, and do not exceed the hydrocarbon concentration of 5 mg/l.

At repair garages, gasoline stations, car-washing facilities, where oily and flammable liquid wastes are produced, separators shall be installed into which all oil-bearing, shall be discharged before emptying in the building drainage system or other point of disposal.

ROTO oil separator is equipped with coalescent filter, automatic closure devices and/or electronic warning system.

Coalescent filters are connected on the integrated wall and can be easily cleaned and replaced.



Volume [L]	NS [L/s]	Surface	Code	Dimensions A x B x C [mm]	Cover [mm]
2.200 L	3	120 m <sup>2</sup>	7300075950	1840 x 1400 x 1600-1900	Ø600
3.000 L	6	240 m <sup>2</sup>	7300075970	2400 x 1400 x 1600-1900	Ø600
3.500 L	10	400 m <sup>2</sup>	7300072750	2080 x 1800 x 2050-2350	Ø600
5.000 L	15	600 m <sup>2</sup>	7300075990	2450 x 1800 x 2050-2350	Ø600
6.000 L	20	800 m <sup>2</sup>	7300075880	2820 x 1800 x 2050-2350	Ø600
8.000 L	30	1.200 m <sup>2</sup>	7300072730	2680 x 2300 x 2500-2880	1xØ600, 1xØ800
10.000 L	40	1.600 m <sup>2</sup>	7300072780	3040 x 2300 x 2500-2880	1xØ600, 1xØ800
12.000 L	50	2.000 m <sup>2</sup>	7300072760	3760 x 2300 x 2500-2880	1xØ600, 1xØ800
16.000 L	65	2.600 m <sup>2</sup>	7300072000	4840 x 2300 x 2500-2880	1xØ600, 1xØ800
20.000 L	80	3.200 m <sup>2</sup>	7300072890	4540 x 2420 x 2800-3100	1xØ600, 1xØ800
25.000 L	100	4.000 m <sup>2</sup>	7300074210	5720 x 2420 x 2700-3000	2xØ600, 1xØ1000
30.000 L	125	5.080 m <sup>2</sup>	7300072010	6550 x 2425 x 2700-3000	2xØ800, 1xØ1000
35.000 L	150	6.100 m <sup>2</sup>	7300075920	7530 x 2425 x 2700-3000	2xØ800, 1xØ1000
40.000 L	200	8.100 m <sup>2</sup>	7300075980	8510 x 2425 x 2700-3000	2xØ800, 1xØ1000
45.000 L	250	10.100 m <sup>2</sup>	7300076000	9870 x 2425 x 2700-3000	2xØ800, 1xØ1000
50.000 L	300	12.100 m <sup>2</sup>	7300072020	10850 x 2425 x 2700-3000	2xØ800, 1xØ1000

## class II

RoSep class II are gravitation separators.

Are designed to achieve a concentration of less than 100mg/l oil under standard test conditions and are suitable for dealing with discharges where a lower quality requirement applies (for example where the effluent passes to the waste water treatment for municipality).

All materials used are highly durable and non-corrosive and all equipment used in the system is produced according to the highest quality standards.



Volume [L]	NS [L/s]	Surface	Code	Dimensions A x B x C [mm]	Cover [mm]
2.200 L	3	120 m <sup>2</sup>	7300075900	1840 x 1400 x 1600-1900	Ø600
3.000 L	6	240 m <sup>2</sup>	7300075910	2400 x 1400 x 1600-1900	Ø600
3.500 L	10	400 m <sup>2</sup>	7300072880	2080 x 1800 x 2050-2350	Ø600
5.000 L	15	600 m <sup>2</sup>	7300075930	2450 x 1800 x 2050-2350	Ø600
6.000 L	20	800 m <sup>2</sup>	7300072710	2820 x 1800 x 2050-2350	Ø600
8.000 L	30	1.200 m <sup>2</sup>	7300072720	2680 x 2300 x 2500-2880	1xØ600, 1xØ400
10.000 L	40	1.600 m <sup>2</sup>	7300072740	3040 x 2300 x 2500-2880	1xØ600, 1xØ400
12.000 L	50	2.000 m <sup>2</sup>	7300072770	3760 x 2300 x 2500-2880	1xØ600, 1xØ400
16.000 L	65	2.600 m <sup>2</sup>	7300072050	4840 x 2300 x 2500-2880	1xØ600, 1xØ400
20.000 L	80	3.200 m <sup>2</sup>	7300072940	4540 x 2420 x 2800-3100	2xØ600
25.000 L	100	4.000 m <sup>2</sup>	7300074220	5720 x 2420 x 2700-3000	2xØ600

Water tanks

Waste water treatment plants

Septic tanks

Grease separators

Oil separators

Shafts

Pumping stations

## By-pass 10%

Bypass separators fully treat all flows generated by rainfall rates of up to 6.5mm/hr. (99% of all rainfall events).

These separators are used on parking area when it is considered an acceptable risk not to provide full treatment for high flows, for example where the risk of a large spillage and heavy rainfall occurring at the same time is small.



Volume [L]	NS [L/s]	Surface	Code	Dimensions A x B x C [mm]	Cover [mm]	Pipes DN [mm]
2.200 L	30/3	1.200 m <sup>2</sup>	7300068900	1840 x 1400 x 1600-1900	Ø600	200
2.600 L	50/5	2.400 m <sup>2</sup>	7300068910	2150 x 1400 x 1600-1900	Ø600	250
3.000 L	80/8	3.200 m <sup>2</sup>	7300068980	2400 x 1400 x 1600-1900	Ø600	250
3.500 L	100/10	4.000 m <sup>2</sup>	7300068920	2080 x 1800 x 2050-2350	Ø600	315
5.000 L	150/15	6.100 m <sup>2</sup>	7300068930	2450 x 1800 x 2050-2350	Ø600	400
6.000 L	200/20	8.100 m <sup>2</sup>	7300068940	2820 x 1800 x 2050-2350	Ø600	400
8.000 L	250/25	10.100 m <sup>2</sup>	7300068610	2680 x 2300 x 2500-2880	Ø600, Ø800	400
10.000 L	300/30	12.100 m <sup>2</sup>	7300068950	3040 x 2300 x 2500-2880	Ø600, Ø800	500
12.000 L	400/40	16.200 m <sup>2</sup>	7300068960	3760 x 2300 x 2500-2880	Ø600, Ø800	500
16.000 L	500/50	20.300 m <sup>2</sup>	7300068970	4840 x 2300 x 2500-2880	Ø600, Ø800, Ø250	600 z.
20.000 L	650/65	25.400 m <sup>2</sup>	7300068560	4540 x 2420 x 2800-3100	2xØ800, Ø250	600 z.
25.000 L	800/80	28.500 m <sup>2</sup>	7300068570	5720 x 2420 x 2700-3000	2xØ600, Ø1000	600 z.
30.000 L	1000/100	40.600 m <sup>2</sup>	7300068580	6550 x 2425 x 2700-3000	Ø800, Ø1000, Ø250	800 z.
35.000 L	1250/125	50.800 m <sup>2</sup>	7300068590	7530 x 2425 x 2700-3000	2xØ800, Ø1000, Ø250	800 z.
40.000 L	1500/150	61.000 m <sup>2</sup>	7300068600	8510 x 2425 x 2700-3000	2xØ800, Ø1000, Ø250	1000 z.
45.000 L	2000/200	81.300 m <sup>2</sup>	7300068620	9870 x 2425 x 2700-3000	2xØ800, Ø1000, Ø250	1000 z.
50.000 L	2500/250	101.600 m <sup>2</sup>	7300068630	10850 x 2425 x 2700-3000	2xØ800, 2xØ1000, Ø250	1000 z.
65.000 L	3000/1500	121.600 m <sup>2</sup>		13460 x 2425 x 2700-3000	2xØ800, 2xØ1000, Ø250	1200 z.

## By-pass 20%

Bypass separators fully treat all flows generated by rainfall rates of up to 6.5mm/hr. (99% of all rainfall events).

These separators are used on parking area when it is considered an acceptable risk not to provide full treatment for high flows, for example where the risk of a large spillage and heavy rainfall occurring at the same time is small.



Volume [L]	NS [L/s]	Surface	Code	Dimensions A x B x C [mm]	Cover [mm]	Pipes DN [mm]
2.200 L	15/3	600 m <sup>2</sup>	7300068800	1840 x 1400 x 1600-1900	Ø600	200
3.000 L	30/6	1.200 m <sup>2</sup>	7300068810	2400 x 1400 x 1600-1900	Ø600	200
3.500 L	50/10	2.000 m <sup>2</sup>	7300068500	2080 x 1800 x 2050-2350	Ø600	250
5.000 L	80/16	3.000 m <sup>2</sup>	7300068820	2450 x 1800 x 2050-2350	Ø600	315
6.000 L	100/20	4.000 m <sup>2</sup>	7300068840	2820 x 1800 x 2050-2350	Ø600	315
8.000 L	150/30	6.100 m <sup>2</sup>	7300068850	2680 x 2300 x 2500-2880	Ø600	400
10.000 L	200/40	8.100 m <sup>2</sup>	7300068860	3040 x 2300 x 2500-2880	Ø600, Ø800	400
12.000 L	250/50	10.100 m <sup>2</sup>	7300068870	3760 x 2300 x 2500-2880	Ø600, Ø800, Ø250	400
16.000 L	325/65	13.200 m <sup>2</sup>	7300068830	4840 x 2300 x 2500-2880	Ø600, Ø800, Ø250	400
20.000 L	400/80	16.200 m <sup>2</sup>	7300068880	4540 x 2420 x 2800-3100	2xØ800, Ø250	500
25.000 L	500/100	20.300 m <sup>2</sup>	7300068890	5720 x 2420 x 2700-3000	2xØ600, Ø1000	600 z.
30.000 L	625/125	25.400 m <sup>2</sup>	7300068510	6550 x 2425 x 2700-3000	2xØ800, Ø1000, Ø250	600 z.
35.000 L	700/150	28.500 m <sup>2</sup>	7300068520	7530 x 2425 x 2700-3000	2xØ800, Ø1000, Ø250	600 z.
40.000 L	1000/200	40.600 m <sup>2</sup>	7300068530	8510 x 2425 x 2700-3000	2xØ800, Ø1000, Ø250	800 z.
45.000 L	1250/250	50.800 m <sup>2</sup>	7300068540	9870 x 2425 x 2700-3000	2xØ800, Ø1000, Ø250	800 z.
50.000 L	1500/300	61.000 m <sup>2</sup>	7300068550	10850 x 2425 x 2700-3000	2xØ800, 2xØ1000, Ø250	1000 z.
65.000 L	2000/400	81.300 m <sup>2</sup>		13460 x 2425 x 2700-3000	2xØ800, 2xØ1000, Ø250	1000 z.

Water tanks

Waste water treatment plants

Septic tanks

Grease separators

Oil separators

Shafts

Pumping stations

Class I coalescing separators do not exceed the hydrocarbon concentration of 5 mg/l.

ROTO oil separator is equipped with coalescent filter, automatic closure devices (on the inflow) and/or electronic warning system.

Coalescent filters are connected on the wall and can be easily cleaned and replaced.

The tank is made from special conductive polyethylene.

Oil separator RoPetrol can be installed inside ex zones.



Volume [L]	NS [L/s]	Code	Dimensions A x B x C [mm]	Cover [mm]	Pipes DN [mm]
5.000	10	7300072758	2660 x 1800 x 2600	Ø250, Ø400, Ø600	200
6.000	15	7300075998	3030 x 1800 x 2600	Ø250, Ø400, Ø600	200
8.000	20	7300075888	2870 x 2300 x 2850	Ø250, Ø400, Ø600	250
10.000	30	7300072738	3330 x 2300 x 2850	Ø250, Ø400, Ø600	250
12.000	40	7300072788	4360 x 2300 x 2850	Ø250, Ø400, Ø600	315

All light liquid separators are supplied for underground installation. There are suitable sampling chambers and alarm equipment available in the range for all nominal sizes.

Leak-tightness up to ground level guaranteed. Low servicing costs thanks to easy-clean inside surface. Due big opening, the coalescent filter can be removed and cleaned easily.



Volume [L]	NS [L/s]	Surface	Code	Dimensions A x B [mm]	Pipes DN [mm]
1.200 L	1,5	60 m <sup>2</sup>	7300775940	Ø1300 x 1500	110
1.500 L	3	120 m <sup>2</sup>	7300775950	Ø1300 x 1750	110
1.700 L	6	240 m <sup>2</sup>	7300775970	Ø1300 x 2000	125
2.350 L	10	400 m <sup>2</sup>	7300772750	Ø1500 x 2150	160
2.700 L	15	600 m <sup>2</sup>	7300775990	Ø1500 x 2400	200
4.000 L	20	800 m <sup>2</sup>	7300775880	Ø1800 x 2350	200
6.000 L	30	1.200 m <sup>2</sup>	7300772730	Ø2300 x 2350	250
7.500 L	40	1.600 m <sup>2</sup>	7300772780	Ø2300 x 2700	315
10.000 L	50	2.000 m <sup>2</sup>	7300772760	Ø2300 x 3400	315

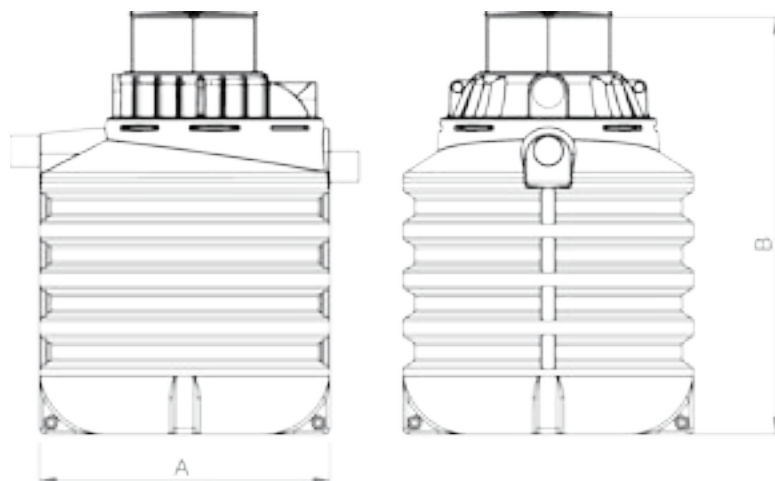

Water tanks

Waste water treatment plants

Septic tanks

Grease separators

Oil separators

Shafts

Pumping stations

## Bypass 10%

These separators are used when it is considered a risk not to provide full treatment for high flows, for example like large spillage and heavy rainfall occurring at the same time.

Robust polyethylene construction for long life, compact vertical design for ease of handling, installation and maintenance.

Contractor friendly bypass connections for different pipe diameters. Oil residue and sludge are easily and quickly removed.



Volume [L]	NS [L/s]	Surface	Code	Dimensions A x B [mm]	Pipes DN [mm]
1.500 L	15/1,5	600 m <sup>2</sup>	7300768820	Ø1300x1750	200
1.700 L	30/3	1.200 m <sup>2</sup>	7300768900	Ø1300x2000	200
2.700 L	50/5	2.000 m <sup>2</sup>	7300768970	Ø1500x2400	250
3.200 L	80/8	3.200 m <sup>2</sup>	7300768980	Ø1800x2000	315
4.000 L	100/10	4.000 m <sup>2</sup>	7300768920	Ø1800x2350	315
6.000 L	150/15	6.100 m <sup>2</sup>	7300768930	Ø2300x2350	400
7.500 L	200/20	8.100 m <sup>2</sup>	7300768940	Ø2300x2700	400

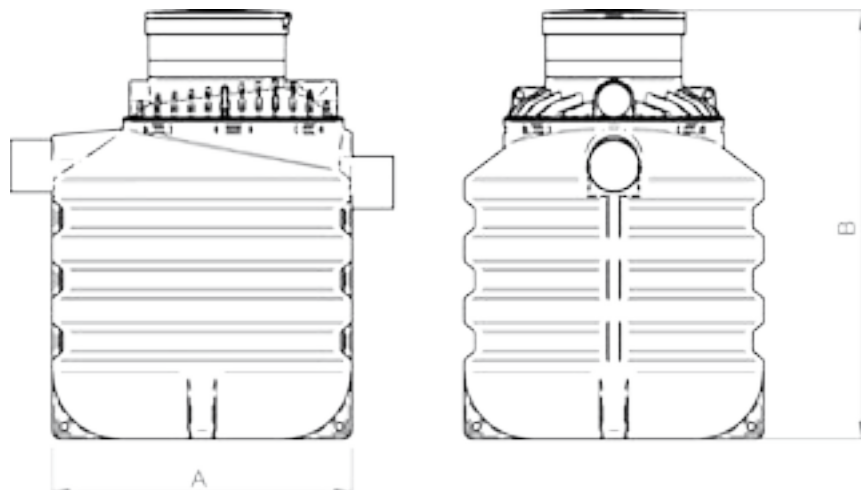

## Bypass 20%

These separators are used when it is considered a risk not to provide full treatment for high flows, for example like large spillage and heavy rainfall occurring at the same time.

Robust polyethylene construction for long life, compact vertical design for ease of handling, installation and maintenance.

Contractor friendly bypass connections for different pipe diameters. Oil residue and sludge are easily and quickly removed.



Volume [L]	NS [L/s]	Surface	Code	Dimensions A x B [mm]	Pipes DN [mm]
1.500 L	15/3	600 m <sup>2</sup>	7300768800	Ø1300x1750	200
1.700 L	30/6	1.200 m <sup>2</sup>	7300768810	Ø1300x2000	200
2.350 L	40/8	1.600 m <sup>2</sup>	7300768960	Ø1500x2150	250
2.700 L	50/10	2.000 m <sup>2</sup>	7300768500	Ø1500x2400	250
4.000 L	75/15	3.000 m <sup>2</sup>	7300768880	Ø1800x2350	315
6.000 L	100/20	4.000 m <sup>2</sup>	7300768840	Ø2300x2350	315
7.500 L	150/30	6.100 m <sup>2</sup>	7300768520	Ø2300x2700	400
8.700 L	200/40	8.100 m <sup>2</sup>	7300768530	Ø2300x3000	400

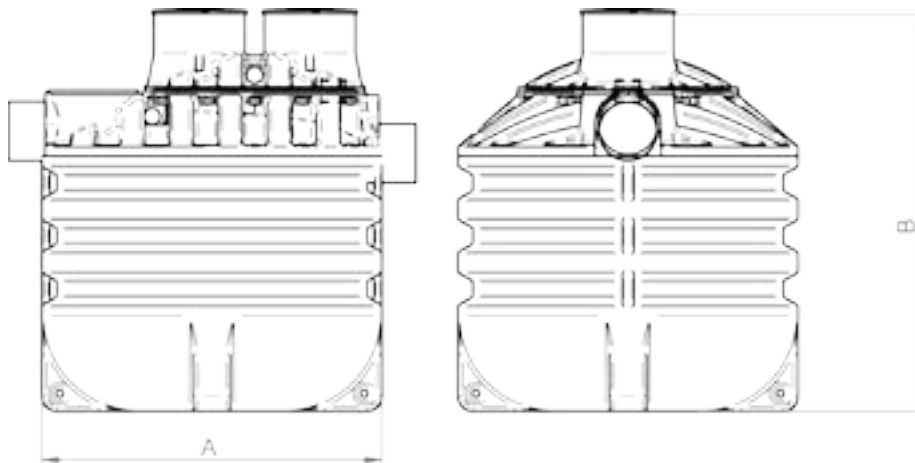

Water tanks

Waste water treatment plants

Septic tanks

Grease separators

Oil separators

Shafts

Pumping stations

Manhole shafts are intended for underground installation on sewer lines as a junction, dividing and revision openings during the maintenance of the sewer manhole.

ROTO shafts are suitable for installation on walking and driving surfaces such as yards, sidewalks, parking lots and roads. The method of installation and construction of the shaft allows access to the shaft to be easy and safe.



## DN400 1/1

Height [H]	Connection pipe	Code
1000 mm	Ø110/125/160	7600059100
1500 mm	Ø110/125/160	7600059110

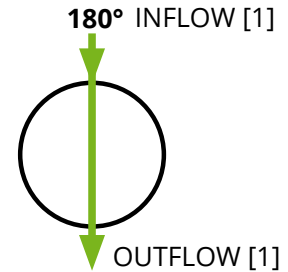

## DN600 1/1, 3/1

Height [H]	Connection pipe	Code 1/1	Code 3/1
1000 mm	Ø160/200	7600070010	7600069680
1250 mm	Ø160/200	7600070020	7600069650
1500 mm	Ø160/200	7600070030	7600069660
1750 mm	Ø160/200	7600070040	7600069670
2000 mm	Ø160/200	7600070050	7600069810
2250 mm	Ø160/200	7600070060	7600069820
2500 mm	Ø160/200	7600070070	7600069830
2750 mm	Ø160/200	7600070080	7600069840
3000 mm	Ø160/200	7600070090	7600069850

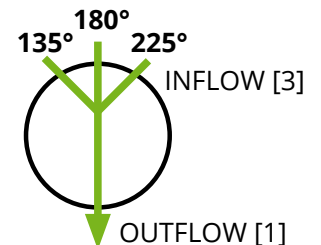
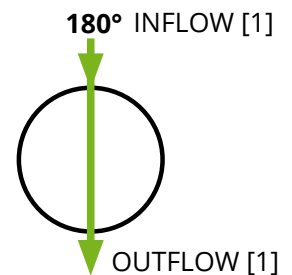

## DN600 3/1

Height [H]	Connection pipe	Code	Connection pipe	Code
1000 mm	Ø160/200/250	7600057000	Ø160/200/250/315	7600805010
1250 mm	Ø160/200/250	7600057030	Ø160/200/250/315	7600805020
1500 mm	Ø160/200/250	7600057010	Ø160/200/250/315	7600805030
1750 mm	Ø160/200/250	7600057020	Ø160/200/250/315	7600805040
2000 mm	Ø160/200/250	7600059220	Ø160/200/250/315	7600805050
2250 mm	Ø160/200/250	7600059230	Ø160/200/250/315	7600805060
2500 mm	Ø160/200/250	7600059240	Ø160/200/250/315	7600805070
2750 mm	Ø160/200/250	7600059250	Ø160/200/250/315	7600805080
3000 mm	Ø160/200/250	7600059260	Ø160/200/250/315	7600805090



# DN800 1/1

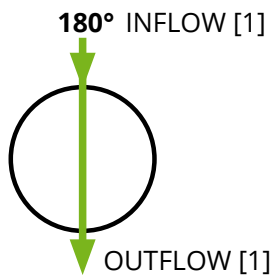

Height [H]	Connection pipe	Code	Connection pipe	Code
1000 mm	Ø200/250/315	7600052000	Ø400	7600052210
1250 mm	Ø200/250/315	7600052010	Ø400	7600052220
1500 mm	Ø200/250/315	7600052020	Ø400	7600052230
1750 mm	Ø200/250/315	7600052030	Ø400	7600052240
2000 mm	Ø200/250/315	7600052040	Ø400	7600052250
2250 mm	Ø200/250/315	7600052050	Ø400	7600052260
2500 mm	Ø200/250/315	7600052060	Ø400	7600052270
2750 mm	Ø200/250/315	7600052070	Ø400	7600052280
3000 mm	Ø200/250/315	7600052080	Ø400	7600052290
3250 mm	Ø200/250/315	7600052090	Ø400	7600052300
3500 mm	Ø200/250/315	7600052100	Ø400	7600052310
3750 mm	Ø200/250/315	7600052110	Ø400	7600052320
4000 mm	Ø200/250/315	7600052120	Ø400	7600052330
4250 mm	Ø200/250/315	7600052130	Ø400	7600052340
4500 mm	Ø200/250/315	7600052140	Ø400	7600052350
4750 mm	Ø200/250/315	7600052150	Ø400	7600052360
5000 mm	Ø200/250/315	7600052160	Ø400	7600052370
5250 mm	Ø200/250/315	7600052170	Ø400	7600052380
5500 mm	Ø200/250/315	7600052180	Ø400	7600052390
5750 mm	Ø200/250/315	7600052190	Ø400	7600052400
6000 mm	Ø200/250/315	7600052200	Ø400	7600052410

# DN800 3/1

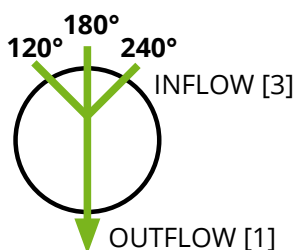

Height [H]	Connection pipe	Code
1000 mm	Ø200/250/315	760006951
1250 mm	Ø200/250/315	760006952
1500 mm	Ø200/250/315	760006953
1750 mm	Ø200/250/315	760006954
2000 mm	Ø200/250/315	760006955
2250 mm	Ø200/250/315	760006956
2500 mm	Ø200/250/315	760006957
2750 mm	Ø200/250/315	760006969
3000 mm	Ø200/250/315	760006970
3250 mm	Ø200/250/315	760006986
3500 mm	Ø200/250/315	760006971
3750 mm	Ø200/250/315	7600069870
4000 mm	Ø200/250/315	7600069720
4250 mm	Ø200/250/315	7600069880
4500 mm	Ø200/250/315	7600069890
4750 mm	Ø200/250/315	7600069900
5000 mm	Ø200/250/315	7600069910
5250 mm	Ø200/250/315	7600069930
5500 mm	Ø200/250/315	7600069940
5750 mm	Ø200/250/315	7600069950
6000 mm	Ø200/250/315	7600069960

Water tanks

Waste water treatment plants

Septic tanks

Grease separators

Oil separators

Shafts

Pumping stations

Water tanks

Waste water treatment plants

Septic tanks

Grease separators

Oil separators

Shafts

Pumping stations

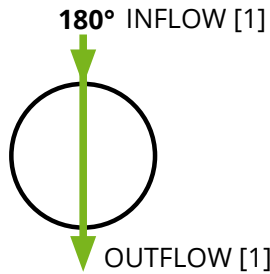

## DN800 1/1

Height [H]	Connection pipe	Code
1250 mm	Ø500/630	7600057040
1500 mm	Ø500/630	7600057050
1750 mm	Ø500/630	7600057060
2000 mm	Ø500/630	7600057070
2250 mm	Ø500/630	7600057080
2500 mm	Ø500/630	7600057090
2750 mm	Ø500/630	7600057100
3000 mm	Ø500/630	7600057110
3250 mm	Ø500/630	7600057120
3500 mm	Ø500/630	7600057130
3750 mm	Ø500/630	7600057140
4000 mm	Ø500/630	7600057150
4250 mm	Ø500/630	7600057160
4500 mm	Ø500/630	7600057170
4750 mm	Ø500/630	7600057180
5000 mm	Ø500/630	7600057190
5250 mm	Ø500/630	7600057200
5500 mm	Ø500/630	7600057210
5750 mm	Ø500/630	7600057220
6000 mm	Ø500/630	7600057230

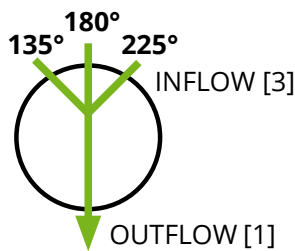
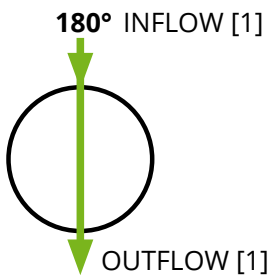

## DN1000 1/1, 3/1

Height [H]	Connection pipe	Code
1250 mm	Ø160/200	7093
1500 mm	Ø160/200	7094
1750 mm	Ø160/200	7097
2000 mm	Ø160/200	7098
2250 mm	Ø160/200	50870
2500 mm	Ø160/200	50871
2750 mm	Ø160/200	50872
3000 mm	Ø160/200	50873

## DN1000 1/1

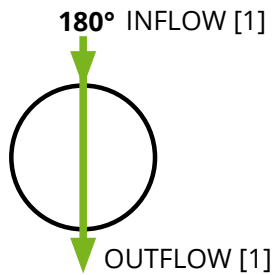

Height [H]	Connection pipe	Code
1250 mm	Ø250/315/400	7600069730
1500 mm	Ø250/315/400	7600069580
1750 mm	Ø250/315/400	7600069590
2000 mm	Ø250/315/400	7600069600
2250 mm	Ø250/315/400	7600069610
2500 mm	Ø250/315/400	7600069620
2750 mm	Ø250/315/400	7600069630
3000 mm	Ø250/315/400	7600069640
3250 mm	Ø250/315/400	7600069760
3500 mm	Ø250/315/400	7600069740
3750 mm	Ø250/315/400	7600069770
4000 mm	Ø250/315/400	7600069750
4250 mm	Ø250/315/400	7600069780
4500 mm	Ø250/315/400	7600069920
4750 mm	Ø250/315/400	7600069790
5000 mm	Ø250/315/400	7600069800
5250 mm	Ø250/315/400	7600069970
5500 mm	Ø250/315/400	7600069980
5750 mm	Ø250/315/400	7600069990
6000 mm	Ø250/315/400	7600070000

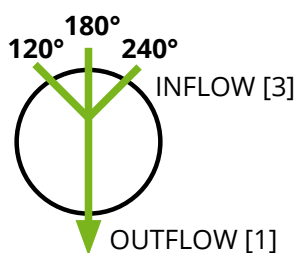

## DN1000 3/1

Height [H]	Connection pipe	Code
1250 mm	Ø250/315/400	760002100
1500 mm	Ø250/315/400	760002101
1750 mm	Ø250/315/400	760002102
2000 mm	Ø250/315/400	760002103
2250 mm	Ø250/315/400	760002104
2500 mm	Ø250/315/400	760002105
2750 mm	Ø250/315/400	760002106
3000 mm	Ø250/315/400	760002107
3250 mm	Ø250/315/400	760002108
3500 mm	Ø250/315/400	760002109
3750 mm	Ø250/315/400	7600021100
4000 mm	Ø250/315/400	7600021110
4250 mm	Ø250/315/400	7600021120
4500 mm	Ø250/315/400	7600021130
4750 mm	Ø250/315/400	7600021140
5000 mm	Ø250/315/400	7600021150
5250 mm	Ø250/315/400	7600021160
5500 mm	Ø250/315/400	7600021170
5750 mm	Ø250/315/400	7600021180
6000 mm	Ø250/315/400	7600021190

Water tanks

Waste water treatment plants

Septic tanks

Grease separators

Oil separators

Shafts

Pumping stations



180° INFLOW [1]

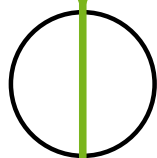

OUTFLOW [1]



180° INFLOW [1]

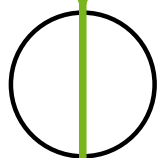

OUTFLOW [1]

## DN1000 1/1

Height [H]	Connection pipe	Code
1250 mm	Ø500/600	7600058410
1500 mm	Ø500/600	7600058230
1750 mm	Ø500/600	7600058240
2000 mm	Ø500/600	7600058250
2250 mm	Ø500/600	7600058260
2500 mm	Ø500/600	7600058270
2750 mm	Ø500/600	7600058280
3000 mm	Ø500/600	7600058290
3250 mm	Ø500/600	7600058300
3500 mm	Ø500/600	7600058310
3750 mm	Ø500/600	7600058320
4000 mm	Ø500/600	7600058330
4250 mm	Ø500/600	7600058340
4500 mm	Ø500/600	7600058350
4750 mm	Ø500/600	7600058360
5000 mm	Ø500/600	7600058370
5250 mm	Ø500/600	7600058420
5500 mm	Ø500/600	7600058430
5750 mm	Ø500/600	7600058440
6000 mm	Ø500/600	7600058450

## DN1000 1/1

Height [H]	Connection pipe	Code
2000 mm	Ø800/1000	7600058120
2250 mm	Ø800/1000	7600058130
2500 mm	Ø800/1000	7600058140
2750 mm	Ø800/1000	7600058090
3000 mm	Ø800/1000	7600058160
3250 mm	Ø800/1000	7600058170
3500 mm	Ø800/1000	7600058180
3750 mm	Ø800/1000	7600058190
4000 mm	Ø800/1000	7600058100
4250 mm	Ø800/1000	7600056000
4500 mm	Ø800/1000	7600056010
4750 mm	Ø800/1000	7600056020
5000 mm	Ø800/1000	7600056030
5250 mm	Ø800/1000	7600056040
5500 mm	Ø800/1000	7600056050
5750 mm	Ø800/1000	7600056060
6000 mm	Ø800/1000	7600056070



## DN800 3/1

Shaft height [H]	Connection pipe	Code
1000 mm	Ø200/250/315/400	5737
1250 mm	Ø200/250/315/400	5738
1500 mm	Ø200/250/315/400	5181
1750 mm	Ø200/250/315/400	5182
2000 mm	Ø200/250/315/400	5183
2250 mm	Ø200/250/315/400	5184
2500 mm	Ø200/250/315/400	5185
2750 mm	Ø200/250/315/400	5186
3000 mm	Ø200/250/315/400	5187
3250 mm	Ø200/250/315/400	5188
3500 mm	Ø200/250/315/400	5189
3750 mm	Ø200/250/315/400	5190
4000 mm	Ø200/250/315/400	5191
4250 mm	Ø200/250/315/400	5192
4500 mm	Ø200/250/315/400	5193
4750 mm	Ø200/250/315/400	5194
5000 mm	Ø200/250/315/400	5195
5250 mm	Ø200/250/315/400	5196
5500 mm	Ø200/250/315/400	5197
5750 mm	Ø200/250/315/400	5198
6000 mm	Ø200/250/315/400	5199



## DN1000 1/1, 3/1

Shaft height [H]	Connection pipe	Code 1/1	Code 3/1
1000 mm	Ø200/250/315/400	7600051000	7600057390
1250 mm	Ø200/250/315/400	7600051010	7600057240
1500 mm	Ø200/250/315/400	7600051020	7600057250
1750 mm	Ø200/250/315/400	7600051030	7600057260
2000 mm	Ø200/250/315/400	7600051040	7600057270
2250 mm	Ø200/250/315/400	7600051050	7600057280
2500 mm	Ø200/250/315/400	7600051060	7600057290
2750 mm	Ø200/250/315/400	7600051070	7600057300
3000 mm	Ø200/250/315/400	7600051080	7600057310
3250 mm	Ø200/250/315/400	7600051090	7600057320
3500 mm	Ø200/250/315/400	7600051100	7600057330
3750 mm	Ø200/250/315/400	7600051110	7600057340
4000 mm	Ø200/250/315/400	7600051120	7600057350
4250 mm	Ø200/250/315/400	7600051130	7600057360
4500 mm	Ø200/250/315/400	7600051140	7600057400
4750 mm	Ø200/250/315/400	7600051150	7600057410
5000 mm	Ø200/250/315/400	7600051160	7600057420
5250 mm	Ø200/250/315/400	7600051170	7600057430
5500 mm	Ø200/250/315/400	7600051180	7600057440
5750 mm	Ø200/250/315/400	7600051190	7600057450
6000 mm	Ø200/250/315/400	7600051200	7600057460

### Shaft body option:

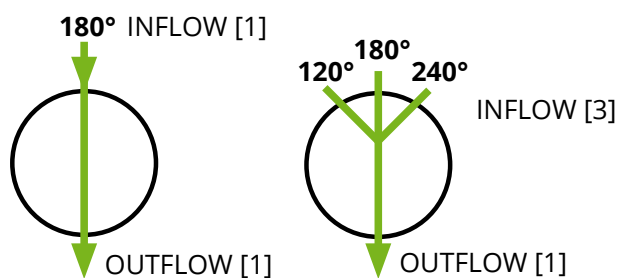

Water tanks

Waste water treatment plants

Septic tanks

Grease separators

Oil separators

Shafts

Pumping stations

Round bottomed shafts are used for the purpose of calming meteor and waste water on steep terrains. They are designed and constructed in such a way that water tangential flows into the body of the shaft and rounds along the round bottom of the shaft all the way to the outflow pipe located at the bottom. Shafts are available in two different diameters DN800 and DN1000 and in different heights up to 5 m. With the appropriate installation and solid lid covers shaft can be installed under the traffic load.

## DN800

Shaft height [H]	Code
850 mm	7600058500
1100 mm	7600058060
1350 mm	7600058070
1600 mm	7600058510
1850 mm	7600058520
2100 mm	7600058530
2350 mm	7600058050
2600 mm	7600058020



## DN1000

Shaft height [H]	Code
900 mm	7600059130
1250 mm	7600059140
1500 mm	7600059150
1750 mm	7600059160
2000 mm	7600059170
2250 mm	7600059180
2500 mm	7600059190
2750 mm	7600059200
3000 mm	7600059210

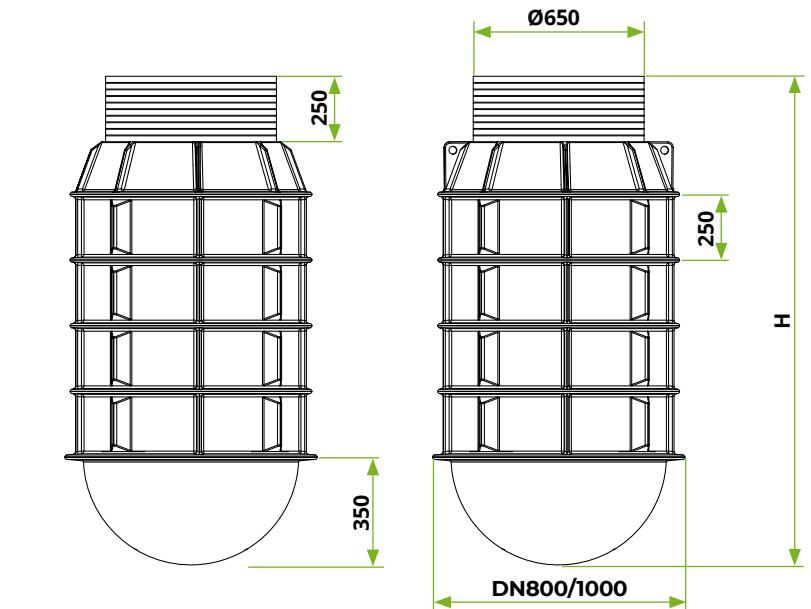

### Connection options:



PE connector and PVC pipe connector

corrugated pipe connection

## DN400

Height [H]	Code
800 mm	7600076480
1000 mm	7600066370
1300 mm	7600076490
1500 mm	7600066350



## DN800

Height [H]	Code
1000 mm	7600059030
1250 mm	7600059040
1500 mm	7600059050
1750 mm	7600059060
2000 mm	7600059070
2250 mm	7600059080
2500 mm	7600059090



## DN500

Height [H]	Code
500 mm	7600059510
1000 mm	7600059520
1250 mm	7600059530
1500 mm	7600059540
1750 mm	7600059550
2000 mm	7600059560



## DN1000

Height [H]	Code
1000 mm	7600059270
1250 mm	7600059280
1500 mm	7600059290
1750 mm	7600059760
2000 mm	7600059770
2250 mm	7600059300
2500 mm	7600059310
2750 mm	7600059320
3000 mm	7600059330



## DN600

Height [H]	Code
1000 mm	7600074430
1250 mm	7600059120
1500 mm	7600074420
1750 mm	7600074410
2000 mm	7600074400



## PE cover options:

DN400  
PE coverDN600  
adapter with cover

Water tanks

Waste water  
treatment plants

Septic tanks

Grease separators

Oil separators

Shafts

Pumping stations

Water tanks

Waste water treatment plants

Septic tanks

Grease separators

Oil separators

Shafts

Pumping stations



# TERMO OKIROTO

Water meter shafts OKIROTO termo are available in three sizes: H=500 mm, H=800 mm in H=1000 mm, with the possibility of delivery as a complete already equipped water meter shaft or as an empty shaft. In the standard equipment at the time of purchase, the shaft also includes a polyethylene [PE] cover for single or double water meter.

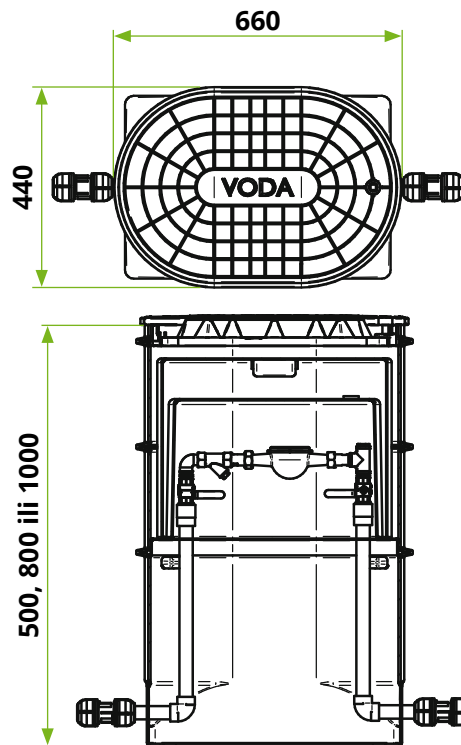

## Cover options:



PE green – for green surfaces  
[šifra: 7906021660]



Solid lid cover class A015  
[šifra: 5802220780]



Solid lid cover class B125

\*In case of ordering a larger quantity of shafts, the shaft cover is also available in other colors.

# QUADROTO

Water meter shaft QuadROTO is available in two sizes: 420x420x400 mm and 520x400x400 mm, with the possibility of delivery as a complete already equipped water meter shaft or as an empty shaft. Water meter shafts QuadROTO are intended for areas where there is no possibility of freezing the soil.

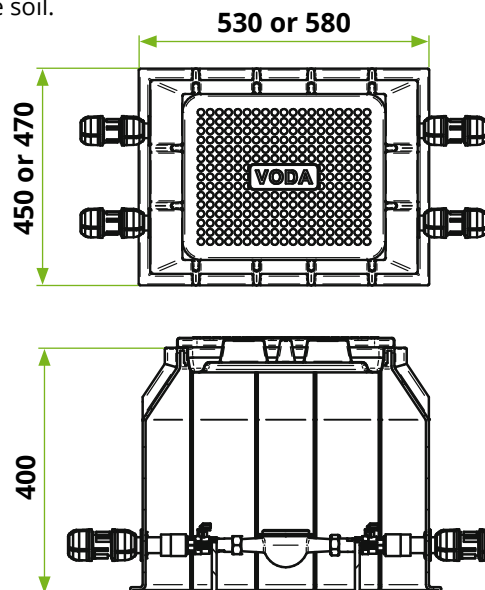

## Cover options:

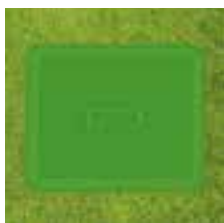

PE green – for green surfaces  
[šifra: 7606059860]



PE black

\*In case of ordering a larger quantity of shafts, the shaft cover is also available in other colors.

## TERMO DN600

Water meter shaft of diameter DN600 is an ideal choice for individual houses or smaller water consumers. Shafts are available as equipped with necessary components or empty. As standard, the shafts contain a thermal insulation jacket around the inner perimeter and a thermal insulated cover.

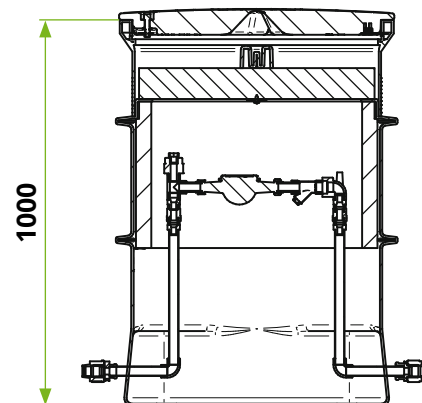
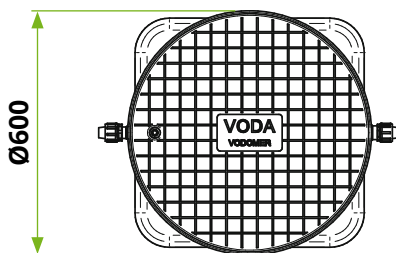

## TERMO DN1000

The water meter thermal shaft DN1000 is suitable for the installation of a larger number of water meters – with the possibility up to 4 water meters. It is available as equipped or empty.

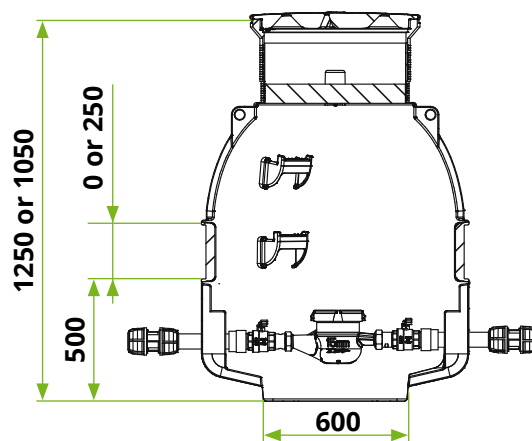

### Cover options:



PE GREEN COVER for lawns [code: 52069]

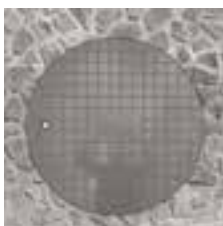

PE concrete gray for paved surfaces [code: 52069]



Solid lid cover black A015 for asphalted surfaces [code: 1280315]

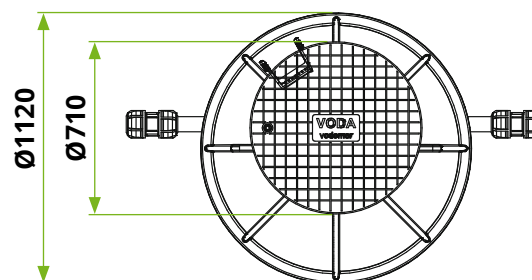

Water tanks

Waste water treatment plants

Septic tanks

Grease separators

Oil separators

Shafts

Pumping stations

Shafts are made of environmentally friendly polyethylene, which is suitable for fecal and clean water. Polyethylene cable shaft is used for the construction of a cable system. Its advantages include high tensile hardness. Due to their light weight, the shafts are easy to transport and install. It is simple to drill a hole in the plastic wall and install rubber seals and pipes  $\Phi$  50,  $\Phi$  100,  $\Phi$  125.

Water tanks

Waste water treatment plants

Septic tanks

Grease separators

Oil separators

Shafts

Pumping stations

## SM1 with cover

Code	Dim. (mm)
7600074330	1020 x 640 x 540

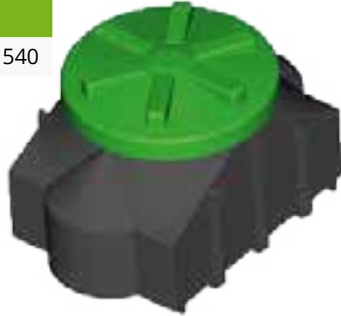

## PKJ DN800

Code	Dim. (mm)
7600073260	$\Phi$ 920 x 950



## SM2

Code	Dim. (mm)
7600074340	1070 x 700



## PKJ DN1000

Code	Dim. (mm)
7600075300	$\Phi$ 1110 x 920



## PKJ DN600

Code	Dim. (mm)
7600074830	$\Phi$ 730 x 830



## MPKJ

Code	Dim. (mm)
7600073280	550 x 420 x 310





Water tanks



Waste water treatment plants

Septic tanks

Grease separators



Oil separators

Shafts



Pumping stations

# RoPump



cabinet for control panel

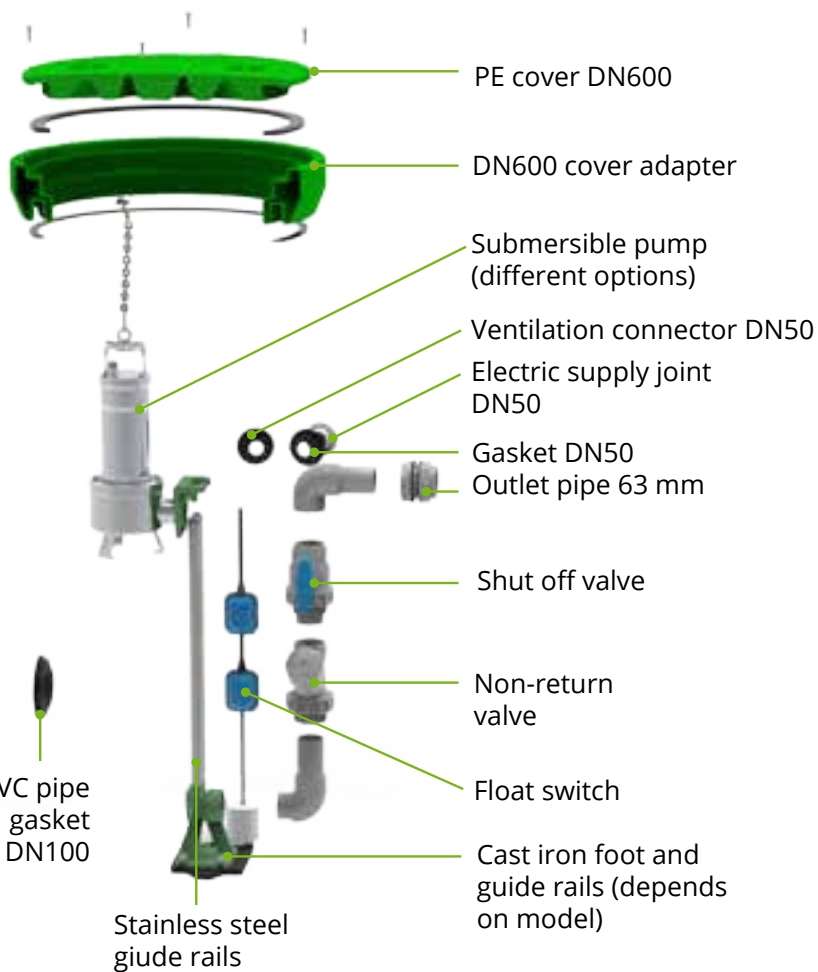

- Water tanks
- Waste water treatment plants
- Septic tanks
- Grease separators
- Oil separators
- Shafts
- Pumping stations

## individual use DN600 with one pump

### Advantages of ROTO pumping stations

- + Reinforced PE shaft, resistant to deformations and negative impacts
- + Adjustable cover for fast and simple adjustment to the terrain
- + Pre-factory assembled pumping stations
- + Large selection of different submersible pumps
- + Up to 50 mm diameter of solid passage in pump
- + Optional stainless steel catching basket
- + Different options of submersible pumps

EN 12050- 2

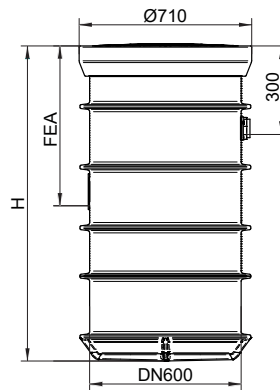
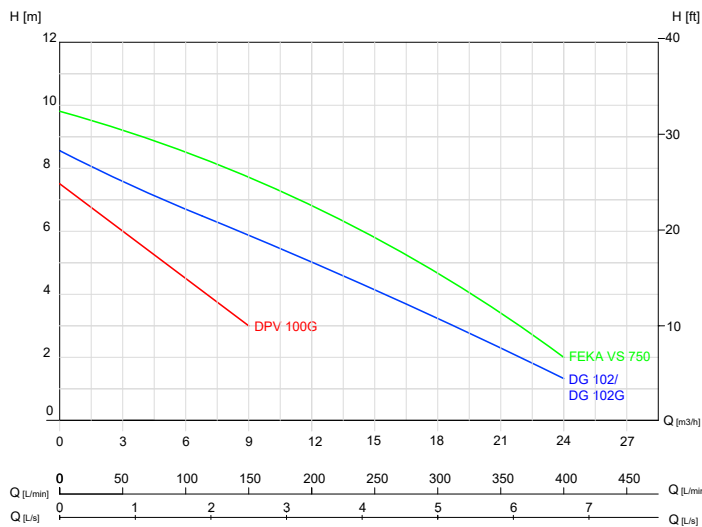

PE SHAFT DN 600 with mounted cast iron foot and stainless steel guide rails for pump (option)



Pump **DG102/ DG102G**



Pump **FEKA VS 750**



Pump **DPV 100G**

Dimensions	Code	FEA [mm]	Pump selection	Required voltage	Pump power	Passage solid [mm]	Inside passage [mm]	Output pipe diameter [mm]
D600 × H1000 mm	7700001041	400	Pentax DG102G	220 - 240V	1,2 kW / 1,61 HP	50	50	63
	7700001031		Pentax DG102	220 - 240V	1,2 kW / 1,61 HP	50	50	63
	7700001051		DAB FEKA VS 750 with rails	220 - 240V	0,75 kW / 1 HP	50	50	63
D600 × H1200 mm	7700001070	600	Pentax DG102G	220 - 240V	1,2 kW / 1,61 HP	50	50	63
	7700001071		Pentax DG102	220 - 240V	1,2 kW / 1,61 HP	50	50	63
	7700001052		DAB FEKA VS 750 with rails	220 - 240V	0,75 kW / 1 HP	50	50	63
D600 × H1500 mm	7700001010	900	Pentax DG102G	220 - 240V	1,2 kW / 1,61 HP	50	50	63
	7700001011		Pentax DG102	220 - 240V	1,2 kW / 1,61 HP	50	50	63
	7700001053		DAB FEKA VS 750 with rails	220 - 240V	0,75 kW / 1 HP	50	50	63
	7700001021		Pentax DPV 100G	220 - 240V	0,75 kW / 1 HP	15	25	32
D600 × H1800 mm	7700001080	1200	Pentax DG102G	220 - 240V	1,2 kW / 1,61 HP	50	50	63
	7700001081		Pentax DG102	220 - 240V	1,2 kW / 1,61 HP	50	50	63
	7700001054		DAB FEKA VS 750 with rails	220 - 240V	0,75 kW / 1 HP	50	50	63
	7700001022		Pentax DPV 100G	220 - 240V	0,75 kW / 1 HP	15	25	32

Water tanks

Waste water treatment plants

Septic tanks

Grease separators

Oil separators

Shafts

Pumping stations

## individual use DN800 with two pumps

### Advantages of ROTO pumping stations

- + Reinforced PE shaft, resistant to deformations and negative impacts
- + Adjustable cover for fast and simple adjustment to the terrain
- + Easy access for maintenance and work inside the shaft
- + Pre-factory assembled pumping stations
- + Large selection of different submersible pumps
- + up to 50 mm diameter of solid passage in pump
- + Optional stainless steel catching basket
- + Different options of submersible pumps

EN 12050- 2

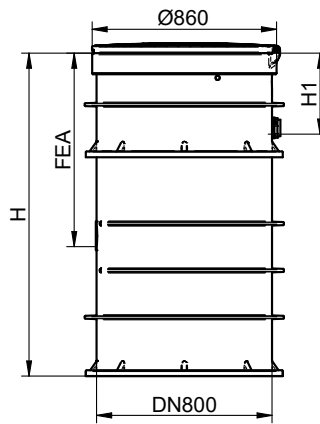
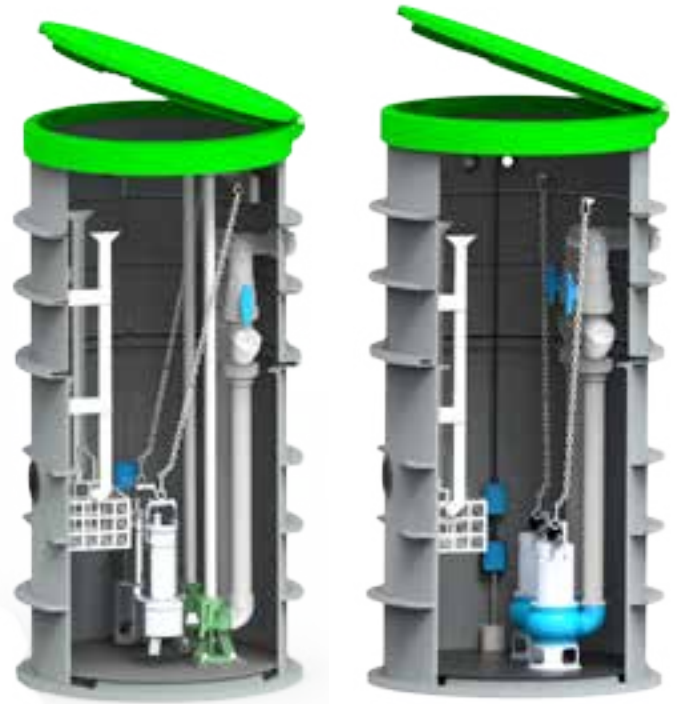

**i** PE SHAFT DN 800 with mounted cast iron foot and stainless steel guide rails for pump (option)

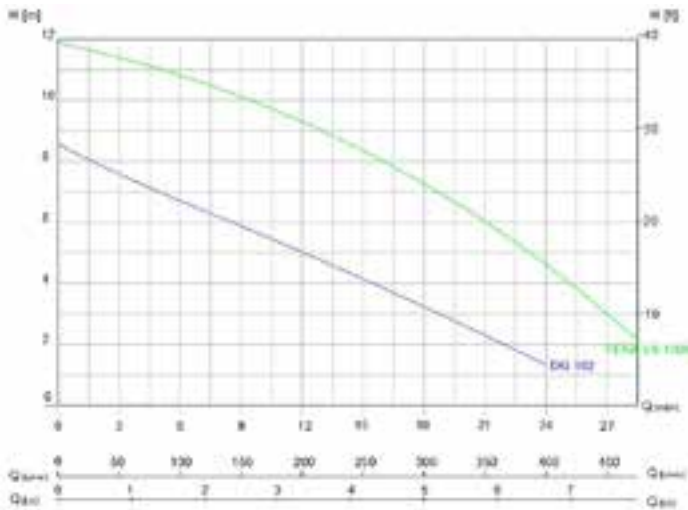

Pump **DG102/ DG102G**



Pump **FEKA VS 1000**

Dimensions	Code	FEA [mm]	Pump selection	Required voltage	Pump power	Passage solid [mm]	Inside passage [mm]	Output pipe diameter [mm]
D800 × H1000 mm	7700002011	400	Pentax DG102	220 - 240V	1,2 kW / 1,61 HP	50	50	63
	7700002051		DAB FEKA VS 1000 with rails	220 - 240V	1 kW / 1,34 HP	50	50	63
D800 × H1200 mm	7700002055	600	Pentax DG102	220 - 240V	1,2 kW / 1,61 HP	50	50	63
	7700002052		DAB FEKA VS 1000 with rails	220 - 240V	1 kW / 1,34 HP	50	50	63
D800 × H1500 mm	7700002033	900	Pentax DG102	220 - 240V	1,2 kW / 1,61 HP	50	50	63
	7700002053		DAB FEKA VS 1000 with rails	220 - 240V	1 kW / 1,34 HP	50	50	63
D800 × H1800 mm	7700002066	1200	Pentax DG102	220 - 240V	1,2 kW / 1,61 HP	50	50	63
	7700002054		DAB FEKA VS 1000 with rails	220 - 240V	1 kW / 1,34 HP	50	50	63



## individual use DN1000 with two pumps

### Advantages of ROTO pumping stations

- + Reinforced PE shaft, resistant to deformations and negative impacts
- + Adjustable cover for fast and simple adjustment to the terrain
- + Pre-factory assembled pumping stations
- + Large selection of different submersible pumps
- + Up to 50 mm diameter of solid passage in pump
- + Optional stainless steel catching basket
- + Different options of submersible pumps

EN 12050- 2

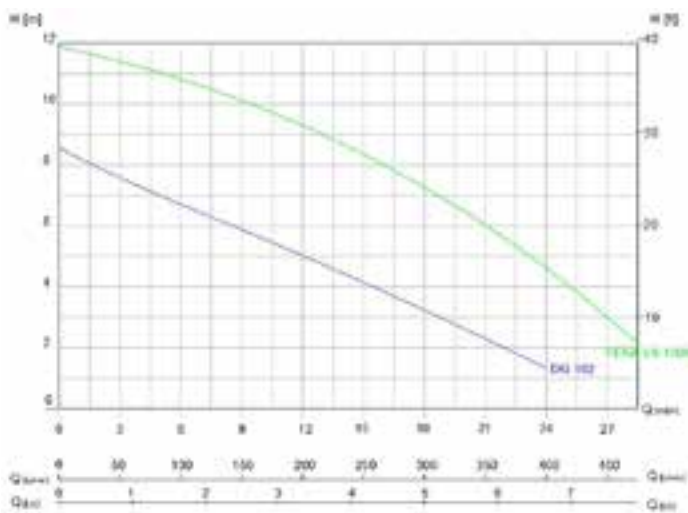
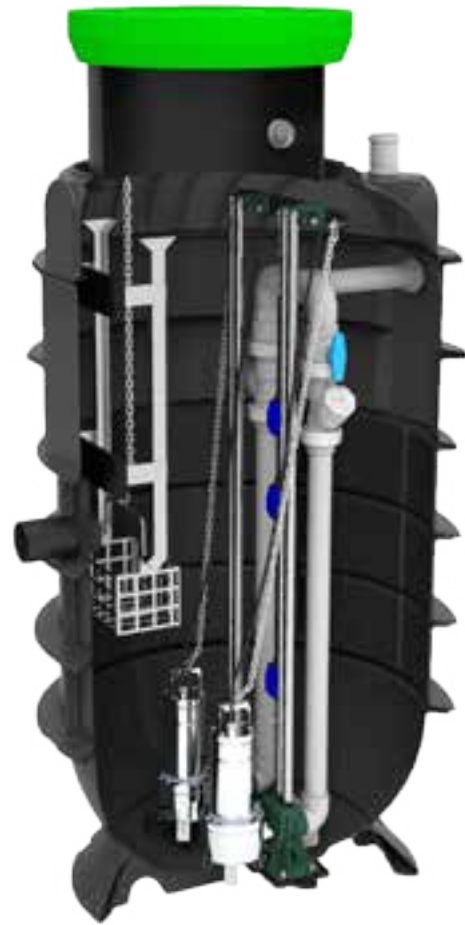

Pump **DG102/**  
**DG102G**



Pump **FEKA**  
**VS 1000**

Dimensions	Code	FEA [mm]	Pump selection	Required voltage	Pump power	Passage solid [mm]	Inside passage [mm]	Output pipe diameter [mm]
D1000 × H2300 mm	7700003031	1200	DAB FEKA VS 1000 with rails	220 - 240V	1 kW / 1,34 HP	50	50	63

Water tanks

Waste water treatment plants

Septic tanks

Grease separators

Oil separators

Shafts

Pumping stations

Water tanks

Waste water treatment plants

Septic tanks

Grease separators

Oil separators

Shafts

Pumping stations

## DN1200 for waste and rain water

- The upper part of the tank can have one large or two separate openings with covers DN600, depends on how many pump you would like to install.
- The bottom of the tank has places for anchoring in case of ground water.
- Simple installation thanks to the low weight of the tank/shaft components and easy connection technique.
- Long-term reliability thanks to the absolutely water-tight chamber system which is resistant to sedimentary deposits and aggressive media as well as root infiltration.
- Simple pump servicing through openings.

EN 12050- 2

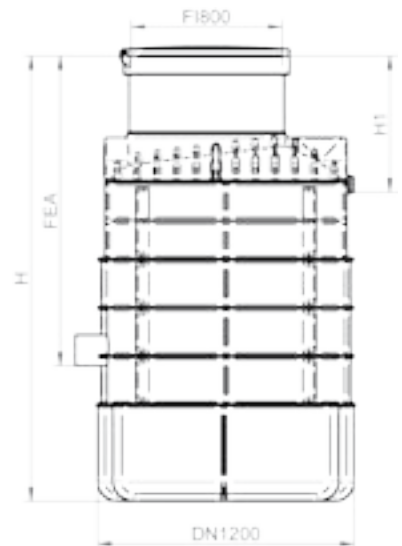
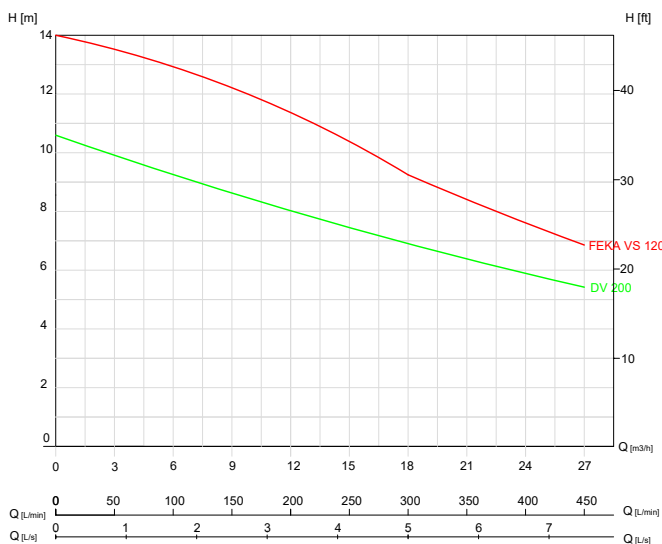
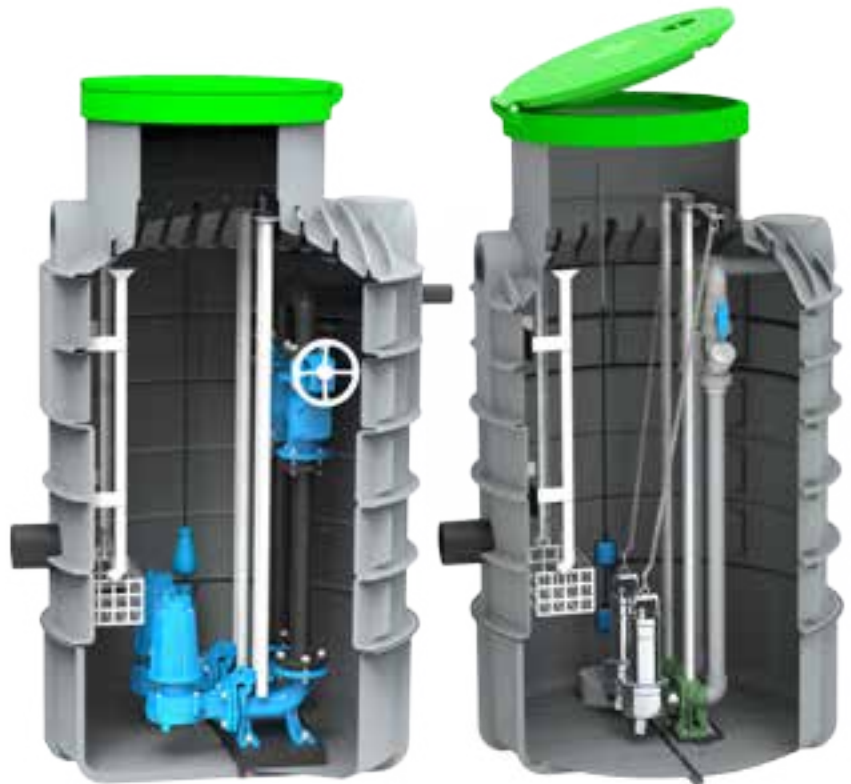

Dimensions	Code	FEA [mm]	Pump selection	Required voltage	Pump power	Passage solid [mm]	Inside passage [mm]	Output pipe diameter [mm]
D1200 × H2300 mm	7700005044	1200	Pentax DV 200	220 - 240V	1,5 kW – 2 HP	50	65	75
	7700002031		DAB FEKA VS 1200 with rails	220 - 240V	1,2 kW / 1,61 HP	50	50	63



Water tanks

Waste water treatment plants

Septic tanks

Grease separators

Oil separators

Shafts

Pumping stations

Pumps for water use in the garden or in the house



Garden set

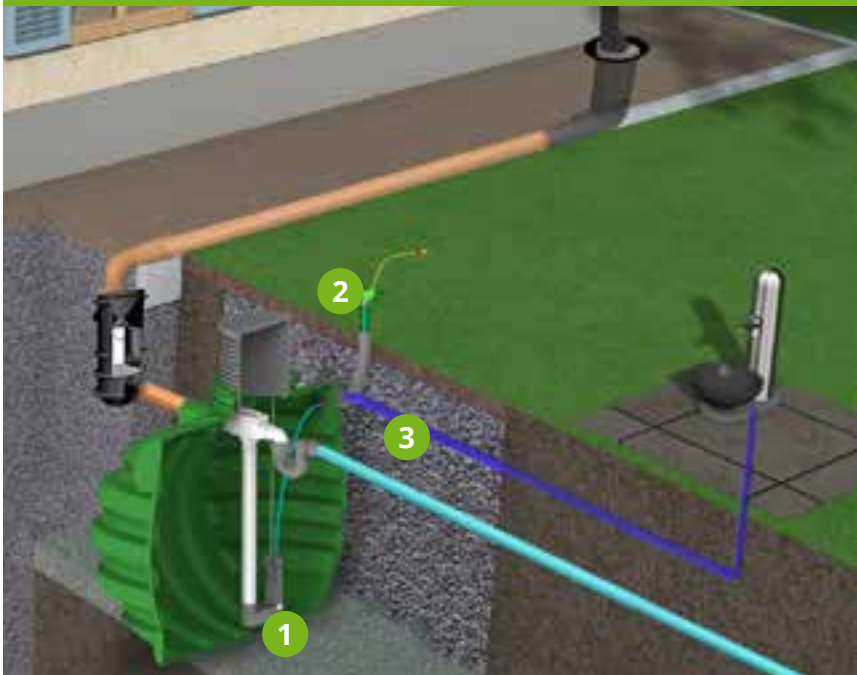

THE SET INCLUDES:

1. Submersible pump with integrated pressure switch and pressure sensor **DAB Diversion 1000** (max flow: 5.7 m<sup>3</sup>/h; maximum pumping height: 36 m; input power: 900 W; weight: 11 kg, 7 m power cable),
2. a garden mini-trough on which a watering hose can be attached,
3. pressure pipe between the pump and the inspection window.



House set



THE SET INCLUDES:

1. Household pump set **Grundfos** (max flow: 3 m<sup>3</sup>/h; maximum pumping height: 15 m; maximum service pressure: 7,5 bar; input power: 660 W)
2. storage tank (used for system security purposes, so the water distribution network is not burdened),
3. a float switch fitted with a 15 m cable,
4. 15 m vacuuming tube with a float bleed,
5. stainless filter and non-returning valve,
6. mixing valve.

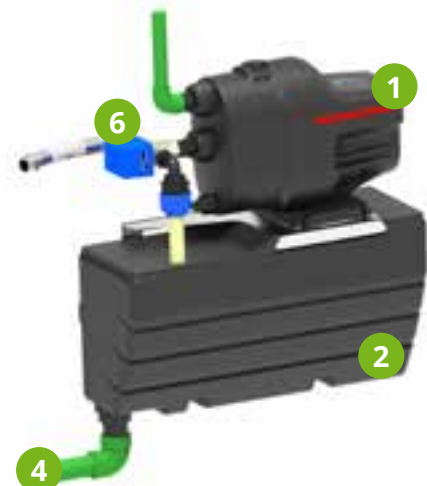

The House Kit is a fully automated system that makes sure rainwater can be used in the house and garden; for the toilet, dishwasher, washing machine, car washing and more.

The House Kit is a pre-prepared pumping system ready for connection to the building. The system works by switching between two sources of water—the rainwater collected in the reservoir and the public pipeline – using a solenoid valve. It gives priority to rainwater, but when the reservoir runs out of water, the system chooses the public network. The House Kit is also upgraded with a small tank, which serves as an intermediate link, as the public network is not allowed to be directly loaded by pressure pumps. The pump is water-cooled, so it runs much quieter than air-cooled pumps.





Water tanks

Waste water treatment plants

**Roterra** water tanks can be connected in series or in parallel to increase the volume capacity of the whole system. Such systems are particularly useful for storing fire water near

buildings, as water storage for irrigation systems or as water storage for settlements. Joints can be made in two ways, either by flange joints or by electrofusion welding.



Connect sequential



Connect parallel

Septic tanks

Grease separators



## Flange joint

The pipes between tanks can be joined using flanged joints. The company prepares the joining elements (flanges, end caps, seals) on the tanks. The joint is then bolted on site and can be done by the user.



Oil separators



## Electrofusion welding



The tanks can also be connected to each other using polyethylene pipes (PE 100), which are joined together using an electrofusion welding process. Depending on how the tank is arranged (parallel or in series), different electrofusion elements are used in electrofusion welding, such as EF couplings and EF elbows. The electrofusion welding itself is carried out on site and requires welding equipment.

Shafts









Pumping stations

## Connection



Water tank type	Connector mounting location	Inlet rubber washer	Welded pipe for connection
RoTerra 1400 from 2.200 up to 3.300 L	upper	up to DN 110	up to DN 200
	lower	/	up to DN 150
RoTerra 1800 from 3.500 up to 6.000 L	upper	up to DN 150	up to DN 300
	lower	/	up to DN 150
RoTerra 2300 from 8.000 up to 30.000 L	upper	up to DN 200	up to DN 300
	lower		up to DN 300
RoTerra 2450 from 30.000 up to 65.000 L	upper	up to DN 300	up to DN 500
	lower	/	up to DN 300



COVERS AND EXTENSIONS

IMAGE	NAME AND CODE	DESCRIPTION	SUITABLE FOR
	<b>COVER DN 400</b> [code: 7100061710]	Cover made of PE material, load capacity up to 2 kN, dimensions Ø400 x 100 mm	<b>RoOki 500 L</b> <b>RoOki 1.000 L</b>
	<b>EXTENSION Ø400 x 200 mm</b> [code: 7100063580]	Extension made of PE material, dimensions Ø400 x 200 mm	<b>RoOki 500 L</b> <b>RoOki 1.000 L</b>
	<b>COVER DN 500</b> [code: 7104111660]	Cover made of PE material, load capacity up to 2 kN, dimensions Ø500 x 80 mm	<b>RoOki 1.500 L</b> <b>RoOki 3.500 L</b>
	<b>EXTENSION Ø500 x 315 mm</b> [code: 7104036060]	Extension made of PE material, dimensions Ø500 x 315 mm	<b>RoOki 1.500 L</b> <b>RoOki 3.500 L</b>
	<b>COVER DN 600</b> [code: 7100520610]	Cover made of PE material, load capacity up to 2 kN, dimension Ø600 mm	<b>RoOki 3.000 L</b> <b>RoOki 5.000 L</b> <b>RoOki 10.000 L</b>
	<b>EXTENSION Ø600 x 250 mm</b> [code: 7100520630]	Extension made of PE material, dimensions Ø600 x 250 mm or Ø600 x 500 mm	<b>RoOki 3.000 L</b> <b>RoOki 5.000 L</b> <b>RoOki 10.000 L</b>
	<b>EXTENSION Ø600 x 500 mm</b> [code: 7100520640]		
	<b>TELESCOPIC EXTENSION AND COVER WITH HINGED OPENING DN 600</b> [code: 7600088710]	Telescopic extension with cover made of PE material, dimensions Ø600 x 400 mm	<b>Roterra</b> <b>Roterra 2450</b> (all volumes) <b>RoBox 5000</b>
	<b>ADDITIONAL EXTENSION DN 600 x 500</b> [code: 7113110700]	Extension made of PE material, dimensions Ø600 x 500 mm	<b>Roterra</b> <b>Roterra 2450</b> (all volumes)
	<b>THREADED ADAPTER FOR FINE FILTER</b> [code: 7100520320]	Threaded adapter for fine filter made of PE material, dimensions Ø800 x 585 mm	<b>RoBox 5000</b>

CAST IRON COVERS

	<b>COVER AND FRAME DN 600 (600)</b> [code: 7100520601]	Cast iron cover and frame, load capacity up to 125 kN, dimensions Ø600 mm	<b>Roterra</b> <b>Roterra 2450</b> (all volumes)
	<b>COVER AND FRAME DN 600 (603)</b> [code: 7100520603]	Cast iron cover and frame, load capacity up to 250 kN, dimensions Ø600 mm	<b>Roterra</b> <b>Roterra 2450</b> (all volumes)
	<b>COVER AND FRAME DN 600 (604)</b> [code: 7100520604]	Cast iron cover and frame, load capacity up to 400 kN, dimensions Ø600 mm	<b>Roterra</b> <b>Roterra 2450</b> (all volumes)

Water tanks

Waste water treatment plants

Septic tanks

Grease separators

Oil separators

Shafts

Pumping stations

Water tanks

Waste water  
treatment plants

Septic tanks











Grease separators



Oil separators





Shafts



Pumping stations

## COVERS AND ADAPTERS

IMAGE	NAME AND CODE	DESCRIPTION	SUITABLE FOR
	<b>COVER DN 600, ASSEMBLED</b> [code: 7100520240]	Cover with adapter made of PE material, load capacity up to 2 kN, dimensions Ø690 x 120 mm	<b>RoCko</b> <b>RoVoda</b> <b>RoDrink</b> (all volumes) <b>Sand trap Ø640</b>
	<b>COVER DN 600</b> [code: 7100520190]	Cover made of PE material, load capacity up to 2 kN, dimensions Ø690 x 65 mm	<b>RoCko</b> <b>RoVoda</b> <b>RoDrink</b> (all volumes) <b>Sand trap Ø640</b>
	<b>COVER DN 600 ADAPTER</b> [code: 7100520310]	Adapter for cover DN 600 made of PE material, dimensions Ø690	<b>RoCko</b> <b>RoVoda</b> <b>RoDrink</b> (all volumes) <b>Sand trap Ø640</b>
	<b>COVER DN 800, ASSEMBLED</b> [code: 7100520620]	Cover with adapter made of PE material, load capacity up to 2 kN, dimensions Ø855 x 130 mm	<b>RoCko</b> <b>RoDrink 2450</b> (all volumes)
	<b>COVER DN 800</b> [code: 7100520600]	Cover made of PE material, load capacity up to 2 kN, dimensions Ø855 x 70 mm	<b>RoCko</b> <b>RoDrink 2450</b> (all volumes)
	<b>COVER DN 800 ADAPTER</b> [code: 7100520610]	Adapter for cover DN 800 made of PE material, dimensions Ø800	<b>RoCko</b> <b>RoDrink 2450</b> (all volumes)
	<b>COVER DN 1000, ASSEMBLED</b> [code: 7100520970]	Cover with adapter made of PE material, load capacity up to 2 kN, dimensions Ø1135 x 160 mm	<b>RoCko</b> (all volumes)
	<b>COVER DN 1000</b> [code: 7100520870]	Cover made of PE material, load capacity up to 2 kN, dimensions Ø1135 x 85 mm	<b>RoCko</b> (all volumes)
	<b>COVER DN 1000 ADAPTER</b> [code: 7100520880]	Adapter for cover DN 1000 made of PE material, dimensions Ø1000	<b>RoCko</b> (all volumes)
	<b>COVER DN 800</b> [code: 7100901810]	Cover made of PE material, load capacity up to 6 kN, dimensions Ø800 x 100 mm	<b>RoCko Ø2310</b> (vsi volumni)
	<b>EXTENSION DN 800 x 750 mm</b> [code: 7100067020]	Extension made of PE material, dimensions Ø800 x 750 mm	<b>RoCko Ø2310</b> (vsi volumni)
	<b>ARTIFICIAL GRASS COVER</b> [code: 7100901820]	An artificial grass cover that elegantly covers the PE cover placed on the grassy areas.	

WASHERS	IMAGE	NAME	CODE	DIMENSIONS
		For smooth PVC / PP pipes, for sealing joints, inlets and outlets. They can be used to connect different elements (tanks, filters, sand traps, shafts ...)		
		<b>Rubber washer Ø50 mm</b>	[code: 7112803020]	dimensions Ø50
		<b>Rubber washer Ø110 mm</b>	[code: 7112803040]	dimensions Ø110
		<b>Rubber washer Ø125 mm</b>	[code: 7112803050]	dimensions Ø125
		<b>Rubber washer Ø160 mm</b>	[code: 7112803230]	dimensions Ø160
		<b>Rubber washer Ø200 mm</b>	[code: 7112803060]	dimensions Ø200
<b>CONNECTORS 1/2" up to 6/4"</b>	[code: 7131440200]	1/2" up to 6/4"		

FILTERS	IMAGE	NAME	CODE	DIMENSIONS
		<b>BUILD-IN FILTER SET</b> [code: 7100062480]	Already built-in filter. Components: inflow pipe DN 110, fine filter, calming and overflow siphon (D3).	300 x 150 x 150
		<b>FILTER - SIEVE</b> [code: 7181530010]	Filter - sieve, which is mounted on the neck of the tank and allows the filtration of larger particles (leaves, branches ...)	Ø400 x 200
		<b>SANITARY WATER FILTER ON THE DISTRIBUTION NETWORK</b> [code: 7100065490]	Combined water filtration system for complete purification of water used in the household. It thoroughly cleans mechanical particles, chlorine and removes any bad smell or taste from the water. If necessary, a UV disinfection device can be installed behind the filter.	/
		<b>DRINKING WATER FILTER ON THE DISTRIBUTION NETWORK</b> [code: 7100092810]	A domestic water station that provides well-purified and microbiologically safe drinking water. Water filtration and UV disinfection system.	/

RAIN GUTTER SHAFTS	IMAGE	NAME	CODE	DIMENSIONS
		<b>GUTTER MANHOLE (SEWER) L</b> [code: 7100070950]	The duct is the link between the gutter and the inlet pipes to the tank. Adjust the lid according to the shape and size of the spout. Outflow DN 110, 125, 160.	Ø250 x 600
	<b>GUTTER MANHOLE (SEWER) I</b> [code: 7100520080]	The duct is the link between the gutter and the inlet pipes to the tank. Outflow DN 110, 125, 160.	Ø250 x 420	

Water tanks  
Waste water treatment plants  
Septic tanks  
Grease separators  
Oil separators  
Shafts  
Pumping stations

	IMAGE	NAME	CODE	DIMENSIONS
Water tanks Waste water treatment plants		The sand and leaves from the roof are separated from the water in the sand trap. The inlet / outlet washers are DN 110 and DN 125. There are two versions available with or without a carbon filter and mesh.		
		<b>SAND TRAP Ø400 x 1000</b>	[code: 7100066373]	Ø400 x 1000
		<b>SAND TRAP Ø400 x 1500</b>	[code: 7100066353]	Ø400 x 1500
		<b>SAND TRAP Ø500 x 1000</b>	[code: 7600059520]	Ø500 x 1000
		<b>SAND TRAP Ø500 x 1500</b>	[code: 7600059540]	Ø500 x 1500
		<b>SAND TRAP Ø640 x 1000</b>	[code: 7600074450]	Ø640 x 1000
		<b>SAND TRAP Ø640 x 1500</b>	[code: 7600074470]	Ø640 x 1500
Septic tanks		<b>ROAD GULLIE Ø400 x 800</b>	[code: 7100076480]	Ø400 x 800
		<b>ROAD GULLIE Ø400 x 1300</b>	[code: 7100076490]	Ø400 x 1300
Grease separators		<b>SAND TRAP WITH FILTER Ø400 x 800 AND COVER</b>	[code: 7100065970]	Ø400 x 800
		<b>SAND TRAP WITH FILTER Ø640 x 800 AND COVER</b>	[code: 7100074500]	Ø640 x 800
Oil separators	IMAGE	NAME	CODE / DESCRIPTION	DIMENSIONS
		<b>WATER LEVEL GAUGE - BASIC</b> Manufacturer: Apolo [code: 7100065560]	Remote wireless water level display. Reach up to 300 m. Easy installation and battery powered.	/
Shafts		<b>WATER LEVEL GAUGE - PROFI</b> Manufacturer: Navis [code: 8001230]	Remote wireless water level display. Reach up to 300 m. Easy installation and battery powered.	/
	Pumping stations		<b>FINE FILTER Ø400 x 430 mm FOR UP TO 400 m² ROOF AREA</b> [code: 7100092800]	It allows efficient cleaning of water flowing from the roof. Inflow 2x DN 110, outflow DN 110 and DN 125.
		<b>FINE FILTER DUO FOR UP TO 700 m² ROOF AREA</b> [code: 7100066180]	It allows efficient cleaning of water flowing from the roof. Inflow je 2x DN 100 / DN 150, outflow 2x DN 100 / DN 150.	873 x 680
		<b>EXTENSION FOR FINE FILTER Ø400</b> [code: 0009282]	Extension for fine filter Ø400.	/

	Name	Type of waste water treatment plant	Material and use	Code	Dimensions
	P4	RoEco 3 - 5PE BioCko 2-10 PE	Polyethylene For external use	7200088310	455 x 235 x 1350
	P5	EcoBox 2 - 9PE EcoBox WEB 2 - 9PE RoMem 4-6PE RoClean 20-40PE RoClean WEB 4-40PE BioCko 11-45 PE	Polyethylene For external use	7200088670	350 x 450 x 1350
	P6	RoEco 8PE RoClean 4-16PE Vodalys 6-14 PE	Polyethylene For internal and external use	Upper part: 7200088020 7200088040  Lower: 7200088030	Upper part: 450 x 355 x 800  Lower part: 470 x 420 x 830 (1630)
	B8	RoClean 50-300 PE RoClean WEB 50-300 PE RoGreen 100-300 PE	Concrete For external use	7102150940	1380 x 640 x 835
	B13	RoGreen 400-500 PE	Concrete For external use	7102150950	1380 x 640 x 1140

Water tanks

Waste water treatment plants

Septic tanks

Grease separators

Oil separators

Shafts

Pumping stations



We provide the user and the maintenance service with a fast delivery of all spare parts and technical assistance in maintenance. Spare parts and maintenance equipment can be ordered through the roto online store [www.shop-roto.si](http://www.shop-roto.si)

## Compressors

	Flow [l/min]	Code
compressor AL 80	80	7111056
compressor AL 120	120	7111049
compressor AL 150	150	7111030
compressor AL 250	250	7111036
compressor AL 300	300	7111032



## Air pipes, valves, air diffusers

	Type of WWTP	Code
pipe DN13x20	RoClean	1210204
pipe DN19x26	RoEco	1210330
electromagnetic valve	RoClean	3144170
electromagnetic valve	RoEco	3144008
plate difuzor	RoClean, EcoBox	1210297
1x pipe difuzor with weight	RoClean, EcoBox	7200140000
2x pipe difuzor with weight	RoClean, EcoBox	7200140010
4x pipe difuzor with weight	RoClean, EcoBox	7200140020
pipe difuzor	RoEco	0006910



## Sample shaft

Volume	Dimensions (mm)	Code
5 L	1000 x 225 x 350	7200088160
16 L	280 x 280 x 380	7200088140
56 L	400 x 1500	7600066350
Ladle for sample		7200888140
Measurecylinder		7208001206



	PICTURE	NAME AND CODE	DESCRIPTION	OIL SEPARATOR
<b>ALARM FOR OIL SLUDGE</b>		<b>ALARM FOR OIL</b> [code: 7300088230]	Separators should be provided with a visual and audible oil alarm. This operates when the oil level reaches 90% of the oil storage volume and indicates that the separator needs immediate emptying for it to continue to work effectively.	<b>All oil separators</b>
		<b>ALARM FOR SLUDGE</b> [code: 7300088240]		
		<b>ALARM FOR OIL AND SLUDGE</b> [code: 7300088250]		
		<b>ALARM FOR OIL SLUDGE AND HIGH LEVEL</b> [code: 7312900250]		
<b>OIL SEPARATORS EQUIPMENT</b>		<b>SAMPLING SHAFT</b> [code: 7600066370]	Sampling Shaft makes it possible to monitor the quality of the water on outflow.	<b>All oil separators</b>
		<b>OIL DETECTION PASTE</b>	Oil detection paste, detect the present and amount of the oil inside the oil separators	<b>All oil separators</b>
		<b>MANUAL MEASURING KIT</b>	Manual measuring kit for oil and sludge (until 6,5 m) kit contains: sampling stick, measuring tape, carrying bag and cleaning towel	<b>All oil separators</b>
		<b>MANUAL LEVEL METER</b>	Manual level meter integrated on automatic closing device	<b>All oil separators</b>
		<b>AUTOMATIC CLOSURE DEVICE</b>	ACD until inflow pipes DN160 ACD over inflow pipes DN200	<b>All oil separators</b>
<b>CAST IRON COVERS</b>		<b>COVER AND FRAME DN 600 (600)</b> [code: 7100520601]	Cast iron cover and frame, load capacity up to 125 kN, dimensions Ø600 mm	<b>All grease separators</b>
		<b>COVER AND FRAME DN 600 (603)</b> [code: 7100520603]	Cast iron cover and frame, load capacity up to 250 kN, dimensions Ø600 mm	<b>All grease separators</b>
		<b>COVER AND FRAME DN 600 (604)</b> [code: 7100520604]	Cast iron cover and frame, load capacity up to 400 kN, dimensions Ø600 mm	<b>All grease separators</b>
<b>ALARM FOR GREASE</b>		<b>ALARM DEVICE FOR GREASE DETECTION</b> [code: 7300088520]	Alarm device that monitors grese layer in the seperator	<b>All grease separators</b>
		<b>ALARM DEVICE FOR GREASE DETECTION AND HIGH FLUID LEVEL DETECTION</b> [code: 7300088241]	Alarm device that monitors grese layer and high levels of fluid in the seperator	<b>All grease separators</b>

Water tanks

Waste water treatment plants

Septic tanks

Grease separators

Oil separators

Shafts

Pumping stations

# RoPump

## High level alarm

[Code: 7200088850]



## Basket

D600 [Code: R000285]  
D800 [Code: R000278]  
D1200 [Code: R000417]

## Fixing of the basket

D600 [Code: R000294]  
D800 [Code: R000401]  
D1200 [Code: R000401]



## Cabinet for control panel

[Code: 7200088310]



## Additional extension

D600 x 500 [Code: 7700000020]  
D800 x 750 [Code: 0080305]



## Cover + extension

DN600 [Code: 7700000020]  
DN800 [Code: 7100520620]  
DN1000 [Code: 7100520970]



## Basket rail

D600, H725 [Code: R000386]  
D600, H1025 [Code: R000387]  
D800, H725 [Code: R000388]  
D800, H1025 [Code: R000389]  
D1200, H1077 [Code: R000416]



**SMART EVO 1 (230V)** [Code: 1290014]  
**SMART EVO 1 (GSM)** [Code: 1290087]  
**SMART EVO 2 (230V)** [Code: 1290015]  
**SMART EVO 2 (GSM)** [Code: 1290088]  
**SMART EVO 2 (3F, 7,5kW)** [Code: 1290089]  
**Express D2-MONO** [Code: 1290090]

## Control unit

SMART EVO combines several functions in a single product; panels for clean water (emptying, filling, pressurisation, etc) and sewage pump panels (emptying and sewage water). SMART EVO offers even more function, safety and control, raising the standard without extra cost!

The SMART EVO control panels are made in an original Elentek thermoplastic ABS design box – they are watertight and self-extinguishing. Each panel has LED lights signaling voltage presence, thermal protection and motor running, and a main switch interlocking door, push buttons for manual or automatic operation, and level relay for probes volt free alarm contacts.

The users and external controls such as float switches and pressure switches are to be connected on the terminals of the main electronic board.



infiltration surface  
resistant  
light weight

Product	Volume [L]	Code	Dimension [mm]
Infiltration tunnel	310	8826	1200 x 800 x 400
Cap	-	8838	700 x 400



- Drening is made of HDPE (high density regenerated polyethylene)
- Drening is a modular element.
- It is designed for the creation of underground retention ponds used for "in-situ" rainwater management.

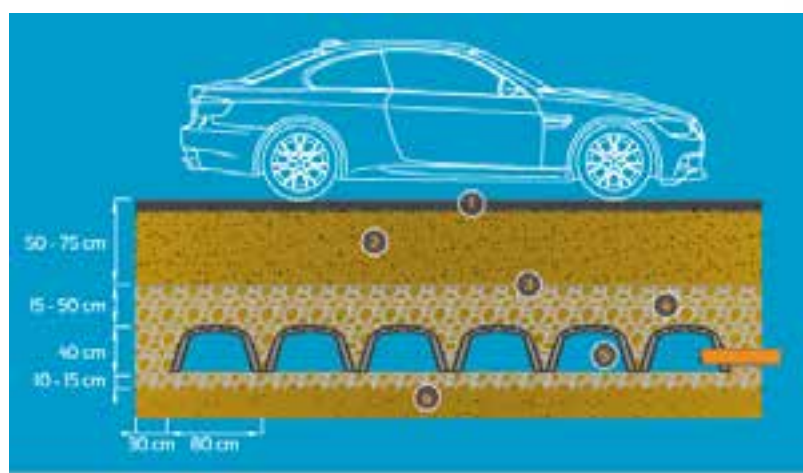

- |                  |                   |
|------------------|-------------------|
| 1 Road finishing | 4 Washed gravel   |
| 2 Covering       | 20/40 mm          |
| 3 Geotextile     | 5 Drening         |
|                  | 6 Existing ground |

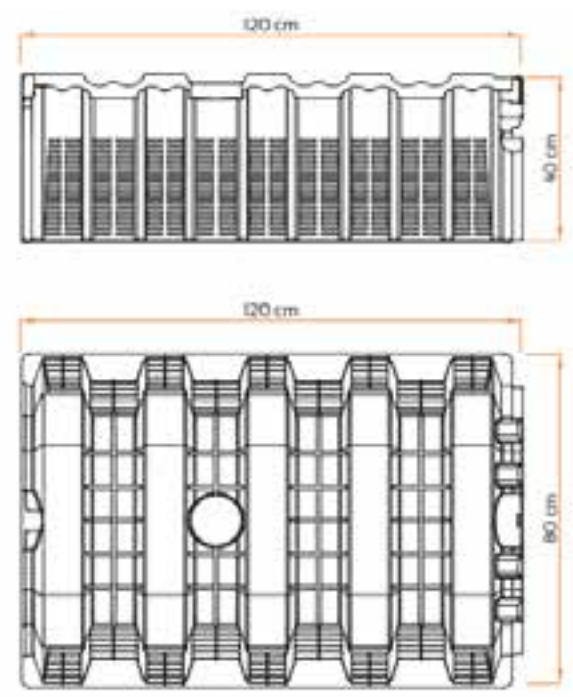

## Installation instructions for **Roto water tanks**

When digging the tank in, the instructions must be followed. In cases where simple self-installation is not possible, please consult the manufacturer or relevant experts. Avalanches, floods and other difficult terrain require the advice of an experienced professional. We also offer advice and a presence at the time of installation to ensure correct and quality installation.



### 1. TRANSPORT OF THE TANK

The tank must be on a level surface during transport. Care must be taken to avoid any sharp edges that could damage the tank. The tank should be secured to the means of transport with polyester or similar straps. Care must be taken to ensure that the belts are not too tight.



### 6. BACKFILL MATERIAL

The material used to fill the tank must be of the correct granulation. The material must be washed free of ice or snow, clay, particles of coarse granulation and other organic particles. Suitable material is sandy gravel or crushed stone with a granular size of 4–16 mm.



### 2. HANDLING THE TANK ON SITE

The tank is lifted and carried using lifting straps. Attach the lifting straps to the tank clamps or to the marked positions. The tank should be moved using suitable construction equipment, taking care to avoid damage to the tank. The tank must not be rolled or dragged.

Backfilling and compaction of the backfill material should be carried out in phases or in 300 mm thick layers. The tank must be filled with water at the same time, so that the level of backfill material and water in the tank is the same at all times. This gives the same lateral pressure on the tank wall. Each layer must be well consolidated with lightweight compaction machines. When backfilling, the elevation and cover must be placed on the tank.



### 3. TEMPORARY STORAGE

The tank must be stored on a suitable, level and smooth surface. You should be aware of any sharp objects on the ground that could cause damage to the tank. If the tank is damaged before installation, this must be reported immediately to the manufacturer. Repairs should be carried out in accordance with the manufacturer's written instructions.



### 7. ANCHORING THE TANK

Anchor lugs (20 mm diameter stainless steel rod) must be installed in the base plate. A rope or cable made of stainless steel and resistant material should be attached to the anchor lugs using wire clips. The rope or wire rope is tensioned using a tension nut. All fixing materials should be made of stainless steel. To prevent direct pressure of the rope on the container, place a geotextile (approx. 100 mm wide) between the surface of the tank and the rope. On the tank on which the clamps are installed, the anchoring should be executed at the clamp lugs. Polyester straps can also be used instead of stainless steel ropes.



### 4. BEFORE INSTALLATION or BUILDING IN

Before installing the tank, the composition and properties of the soil must be carefully checked. The floor of the construction pit must be hardened and stable. In case of poor bearing capacity of the ground, a cushion with gravel material 40 cm thick or concrete must be constructed. The cushion must be consolidated to a minimum compaction of 60 MPa. Excavated material must be removed from the excavation pit so that it does not mix with the backfill material.



### 8. AB BASE PLATE

The reinforced concrete base slab should be placed on a hardened base. The minimum thickness of the AB foundation slab is 200 mm (sizing to be carried out by a structural engineer). It should be reinforced with two reinforcing nets. The base plate should be 600 mm wider than the floor dimensions of the tank.



### 5. EXCAVATION DIMENSIONS

The floor area of the construction pit should be 60–100 cm larger than the floor area of the tank. The tank must be a minimum of 150 cm from the building and a minimum of 200 cm from the carriageway. If the type of terrain permits, dig a construction pit with walls as vertical as possible (the embankment angle of the soil and safe working measures must be taken into account). All applicable safety and building regulations must be observed during installation. The depth of the excavation must be coordinated with the design and dimensions of the tank.



### 9. TRAFFIC LOAD

The traffic load must not be transferred directly to the tank. Therefore, an AB relief slab must be constructed above the tank. The AB slab is dimensioned by a structural engineer according to the load and the AB slab must be properly supported. In case of traffic loads, an LTŽ cover must be installed on the tank.



### 10. PHOTODOCUMENTATION OF INSTALLATION

In order to claim the against the warranty in case of damage to the tank, the entire installation must be photo-documented. The manufacturer shall not be held liable for any damage to the tank caused during the digging process in case of incorrect installation of the tank.

## Easy installation – **WALKING AREA**



### 1. PHASE - Pit preparation

The floor area of the construction pit must be 60-100 cm larger than the floor area of the tank. If the type of terrain permits, dig a construction pit with walls as vertical as possible (the embankment angle of the soil and safe working measures must be taken into account).

The planum of the construction pit must be level and consolidated. If the soil is less load-bearing, a rehabilitation cushion with gravel material 40 cm thick or lean concrete is required. The rehabilitation cushion must be consolidated to a minimum compaction of 60 MPa

A sand bed at least 15 cm thick shall be laid on the prepared sub-base. Sand with a granulation of 0-4 mm is placed in the construction pit and levelled.



### 2. PHASE – installation in the pit

Carefully place the tank on a level sand bed (lifted by a suitable mobile lifting or working machine) and level it using a water balance.

Adjust the tank extensions (inspection openings) to the final ground level.

The telescopic extension adjusts to the final terrain by tightening and loosening. The integrated extension is adjusted by removing the adapter with the cover and cutting the neck to the appropriate final ground level.

It is important that the extension and the cover are placed on the tank when backfilling.



### 3. PHASE – backfill

Backfill the tank up to 30 cm measured from the bottom of the tank with 4-16 mm fraction and simultaneously fill it with water up to 30 cm measured from the bottom of the tank (fill all compartments).

Care must be taken to ensure that the fraction is well fed under the rounded parts of the tank. The filling of the tank with water and backfilling with fraction is repeated in 30 cm increments until the tank is backfilled to the first connection.

When backfilling the tank, we need to pay attention to the level of the connections (inlet, outlet, etc.) to ensure that they are made in time.



### 4. PHASE – Final embankment

Once the connections have been properly connected and are watertight, the pit is backfilled with fraction up to the last 25 cm.

Place geotextile over the backfill with 4-16 mm fraction – over the entire tank area.

The last 25 cm of backfill is made with the soil excavated when digging the construction pit. Care must be taken not to fill the tank lid.

The maximum height of the embankment above the top of the tank is 80 cm.

In case of impermeable terrain, drainage around the tank is mandatory.

### UNDERGROUND WATER

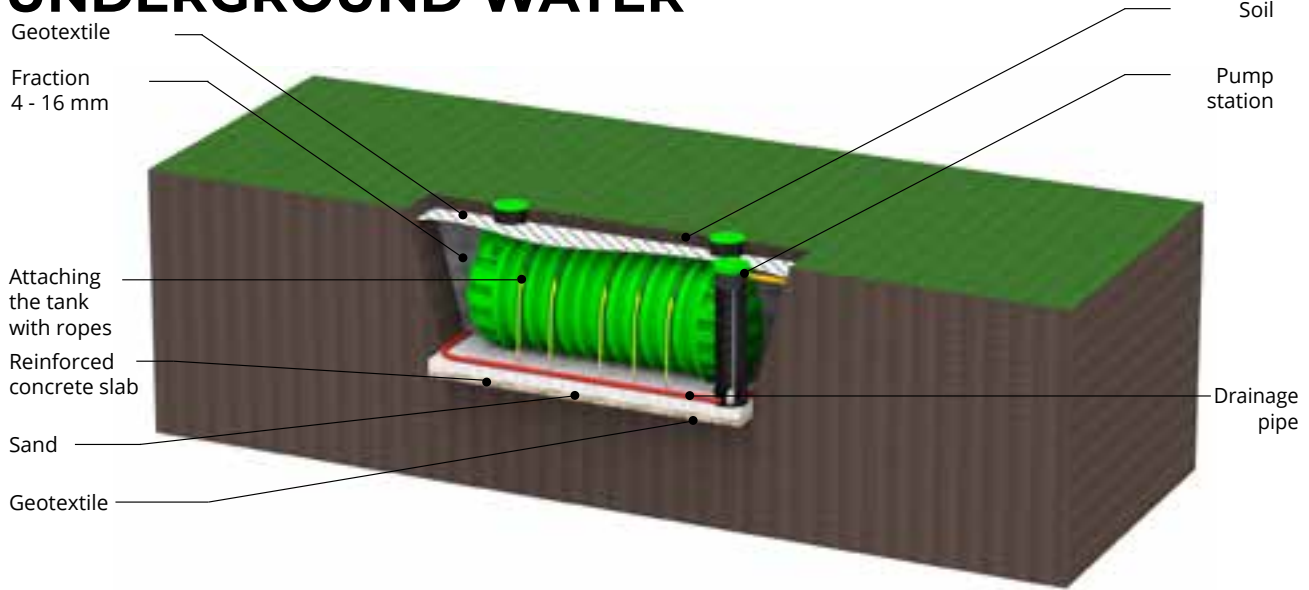

### ROAD SURFACES

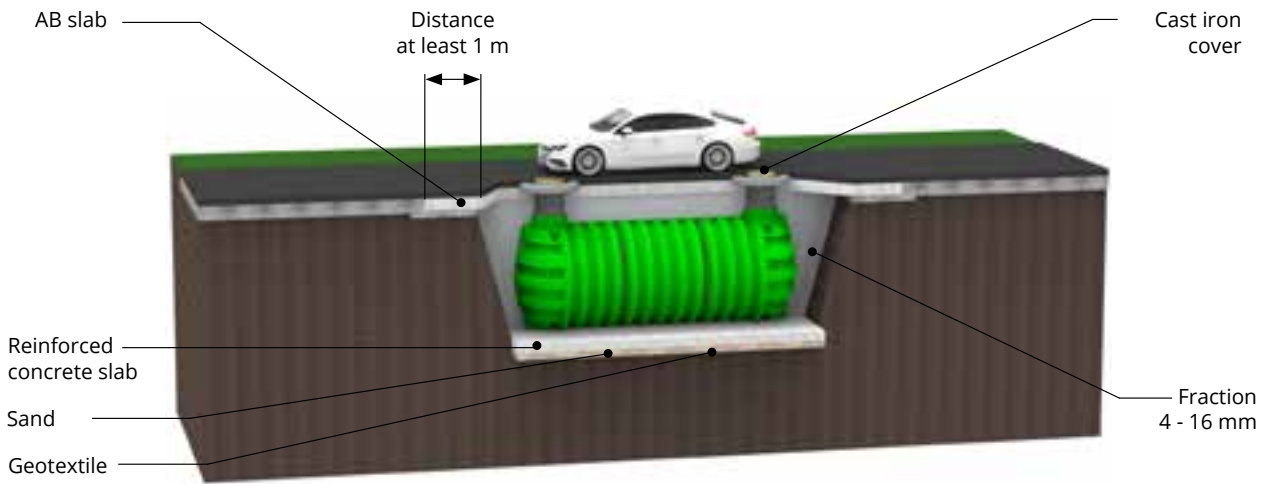

### DEEP INSTALLATION

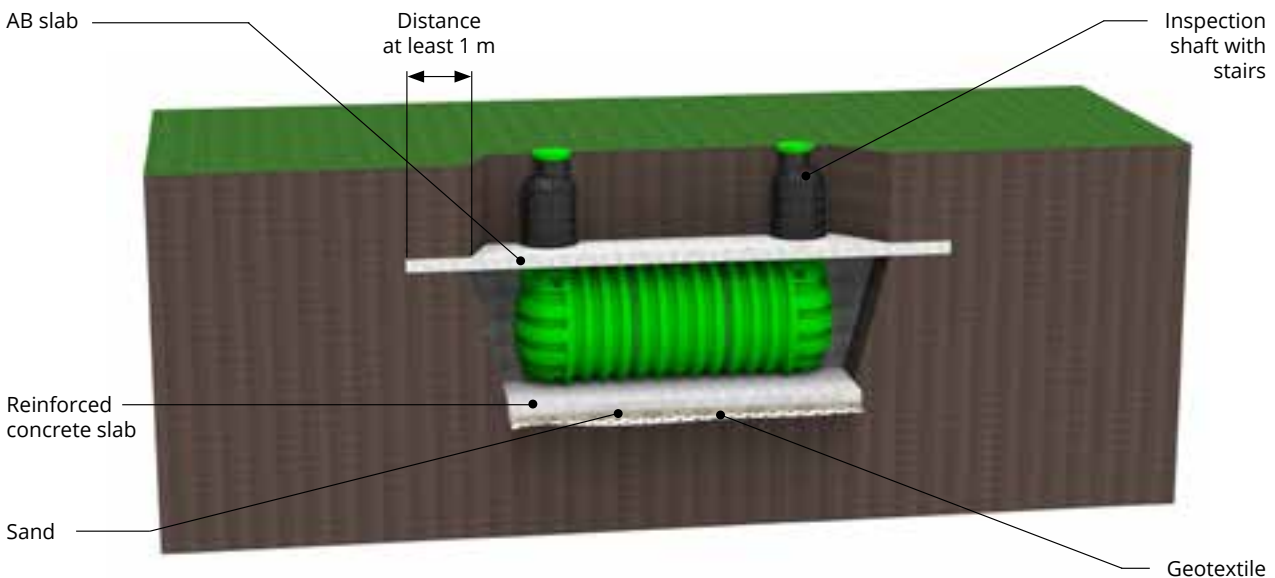

# Certificates

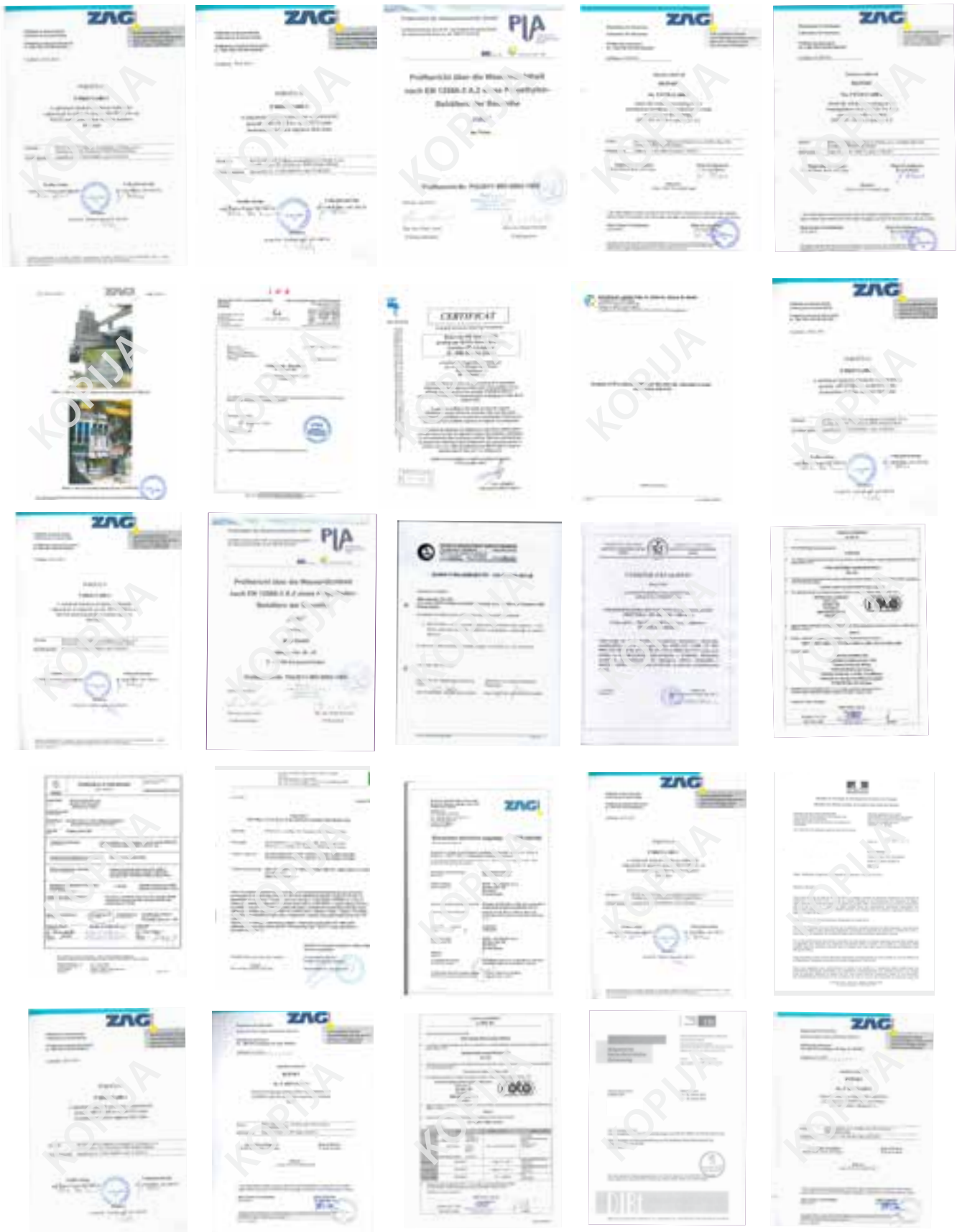



ROTO Slovenija d.o.o.  
Puonci 12  
9201 Puonci  
Slovenia  
eco@roto.si  
+386 2 52 52 152

**WWW.ROTOECO.EU**