

# water tanks

INTELLIGENT **eco** SOLUTIONS



Roto, an international company based in Murska Sobota, specialises in the production of plastic mass. The roots of the family-run business go back to 1949. ROTO employs more than 450 people in 7 factories located in 4 countries. Roto generated revenues of €63 million in 2020, selling products in 55 countries around the world.

Roto is Europe's leading rotomoulding company, producing more than 4,000 different products. The company's development is ensured by continuous innovation, new technologies and materials that ROTO develops with scientific institutes, universities and other companies.

The Roto-branded product groups are divided into four segments: products for agriculture, garden, sport and ecology. The use of composites and biodegradable and recycled polymers enables the production of the most complex products on the market.



**EY**  
EY the most successful family business in 2016

Roto also manufactures a wide range of readymade products for various industries such as automotive, marine, construction and agricultural machinery, aquaculture and logistics. Added value comes from innovative design, the use of intelligent polymers and composites, and state-of-the-art manufacturing.



Černelavci, Slovenia



Puconci, Slovenia



Vinica, Macedonia

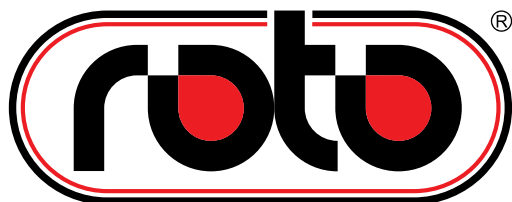

# Distribution across Europe

ALWAYS NEAR TO YOUR CONSTRUCTION SITE

## Slovenia

tel: +386 2 52 52 152  
projekt@roto.si

## Austria

tel: +43 664 21-03 495  
austria@roto-group.eu

## Italy

tel: +39 328 225 05 17  
italy@roto.si

## France

tel: +33 6 35 41 80 31  
info@roto-france.com

## England

tel: +44 (0) 7880 603010  
sales@roto-group.co.uk

## Germany

tel: +49 (0) 151 67188855  
germany@roto-group.eu

## Hungary

tel: +36 30 500 9003  
hungary@roto-group.eu

## Croatia

tel: +385 91 14 395 12  
info@roto-grad.t-com.hr

tel: +385 98 240 332  
info@okiroto.hr

## Serbia

tel: +381 66 668 00 43  
alibunar@roto.si

## Macedonia

tel: +389 3 33 63 516  
zoran@roto.mk

## Bosnia

tel: +387 33 780 096  
prodaja@roto.ba

## Bulgaria

tel: +359 88 676 67 97  
bulgaria@roto-group.eu

## Slovakia

tel: +421 905 258 292  
slovakia@roto-group.eu

● Production

● Representative offices



Pregrada, Croatia



Ivanić Grad, Croatia



Alibunar, Serbia

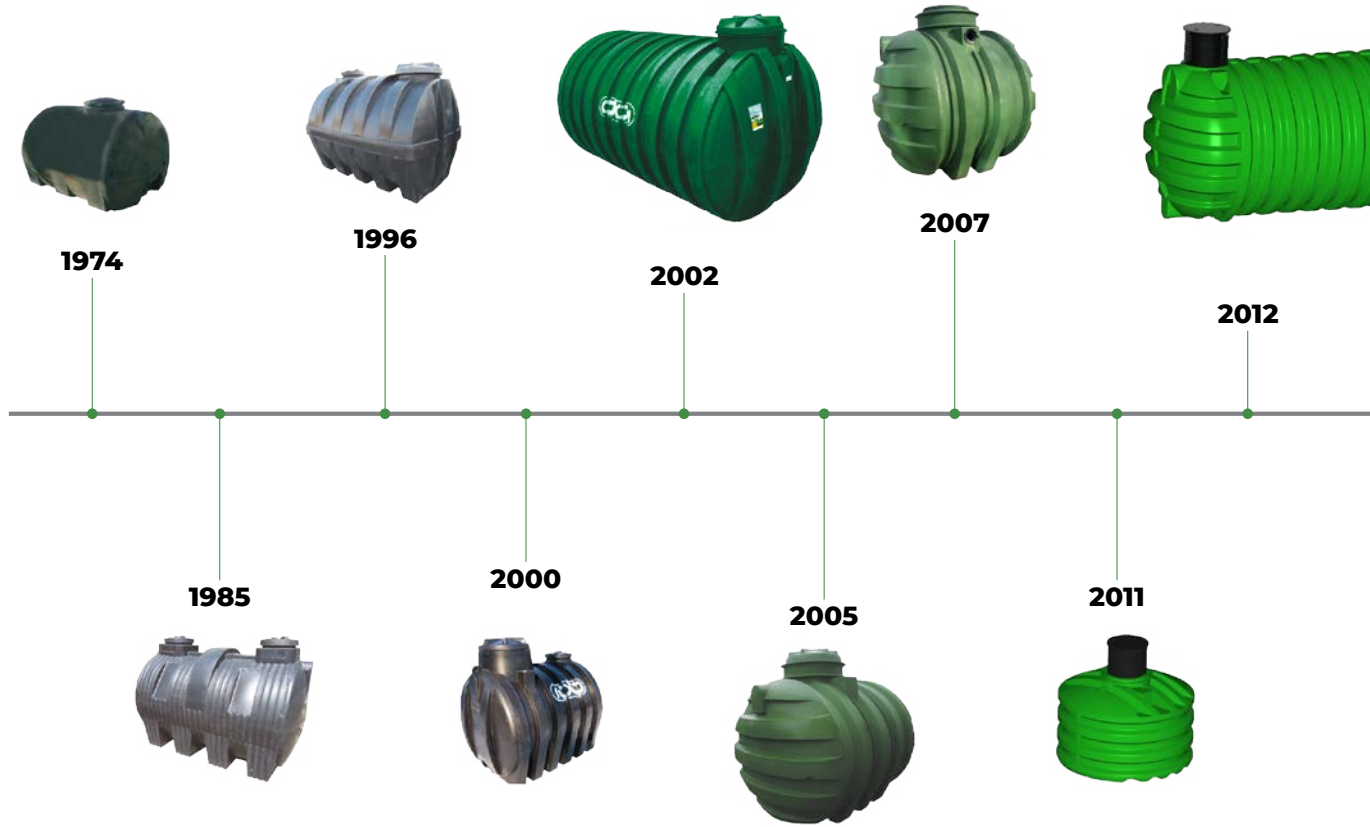

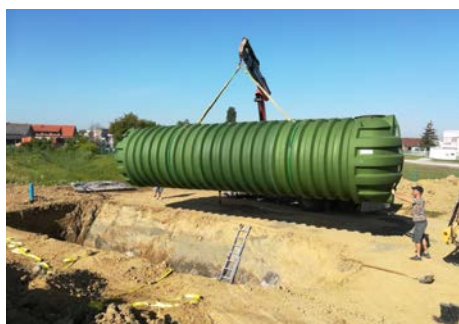
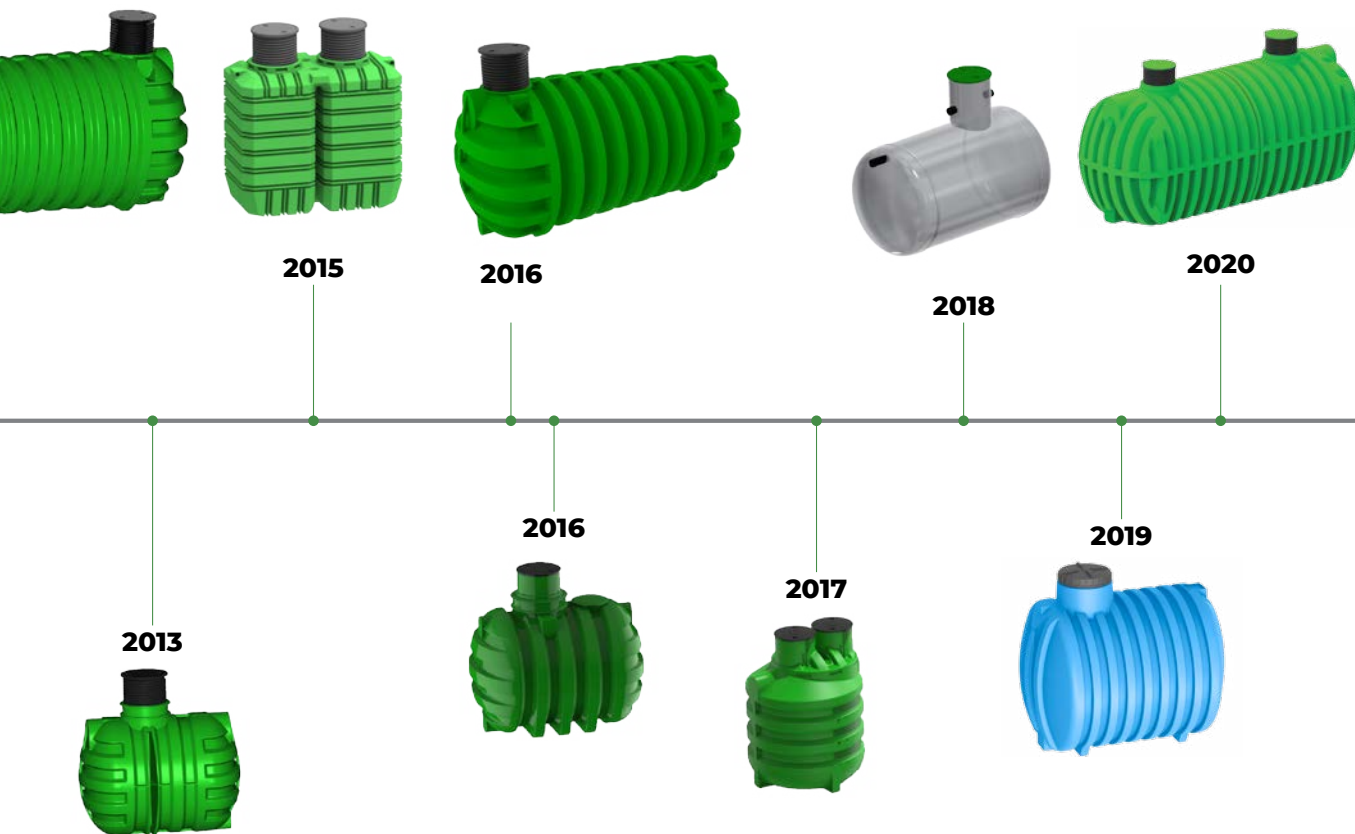

# TABLE OF CONTENT

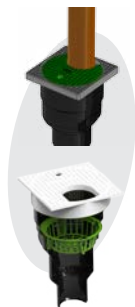
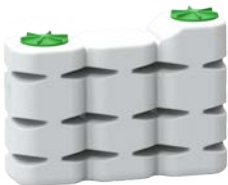

- 7 **WATER TANKS - HORIZONTAL**
- 9 ROTERRA 1400, 2.200 - 3.300 L
- 10 ROTERRA 1800, 3.500 - 6.000 L
- 11 ROTERRA 2300, 8.000 - 16.000 L
- 12 ROTERRA 2300, 22.000 - 30.000 L
- 15 ROTERRA 2450, 30.000 - 65.000 L
- 16 ROVODA, 3.500 - 6.000 L
- 17 ROOKI, 500 - 10.000 L
- 18 **FIRE WATER SYSTEM**
- 20 **RAINWATER COLLECTING SYSTEM**
- 22 PUMPS, to use water in the garden and in the house
- 23 **CONNECTING TANKS**
- 25 **DRINKING WATER SYSTEMS**
- 27 RODRINK, 2.200 - 6.000 L
- 28 RODRINK, 8.000 - 16.000 L
- 29 RODRINK, 22.000 - 30.000 L
- 30 RODRINK 2450, 30.000 - 65.000 L
- 31 **WATER TANKS - VERTICAL**
- 33 ROCKO,  $\varnothing$ 1300 - 900 - 3.000 L
- 34 ROCKO,  $\varnothing$ 1500 - 2.000 - 2.700 L
- 35 ROCKO,  $\varnothing$ 1800 - 3.200 - 5.000 L
- 36 ROCKO,  $\varnothing$ 2300 - 6.000 - 10.000 L
- 37 **WATER TANKS - FLAT**
- 38 ROBOX, 5.000 L
- 39 ROCKO, 3.500 - 5.000 L
- 40 ROTOM, 2.300 L
- 41 **OVERGROUND TANKS**
- 42 ROQUADRO, 250 - 2.000 L
- 42 ROTO OTW, 60 - 500 L
- 42 ROTO M, 500 - 1.500 L
- 43 RONDO, 325 - 15.000 L
- 43 ROTRANS, 300 - 5.000 L
- 44 **ADDITIONAL EQUIPMENT**
- 48 **INSTALLATION INSTRUCTIONS**
- 50 **SPECIAL INSTALLATIONS**



**WATER TANKS - HORIZONTAL**

# Roterra

## HINGED COVER

The Roterra tank lid with gasket ensures water tightness. The lid is hinged to the telescopic extension, making it easy to open.

## TELESCOPIC EXTENSION

The telescopic extension is shaped like a screw. This mode allows quick and easy adjustment of the height when digging. The dimensions of the extension are  $\text{Ø}600 \times 400 \text{ mm}$ .

## POSSIBILITY OF CONNECTION

INFLOW



OUTFLOW

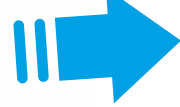

## POSSIBILITY OF CONNECTION

## REINFORCING RIBS

Reinforcing ribs on both sides ensure the stability of the tank and protection in case of high water tables.

## Roterra water tank features:



Underground tank installation needed



Material: polyethylene



Made in one piece, 100% waterproof



Excellent statics, resistance to earth pressures and external forces



Wall thickness 8 - 14 mm



Possibility to adjust the height of the extension to the requirements of the terrain



The product can be 100% recycled after use

BASIC EQUIPMENT INCLUDES: telescopic extension and lid.

# Roterra 1400

2.200 - 3.300 L

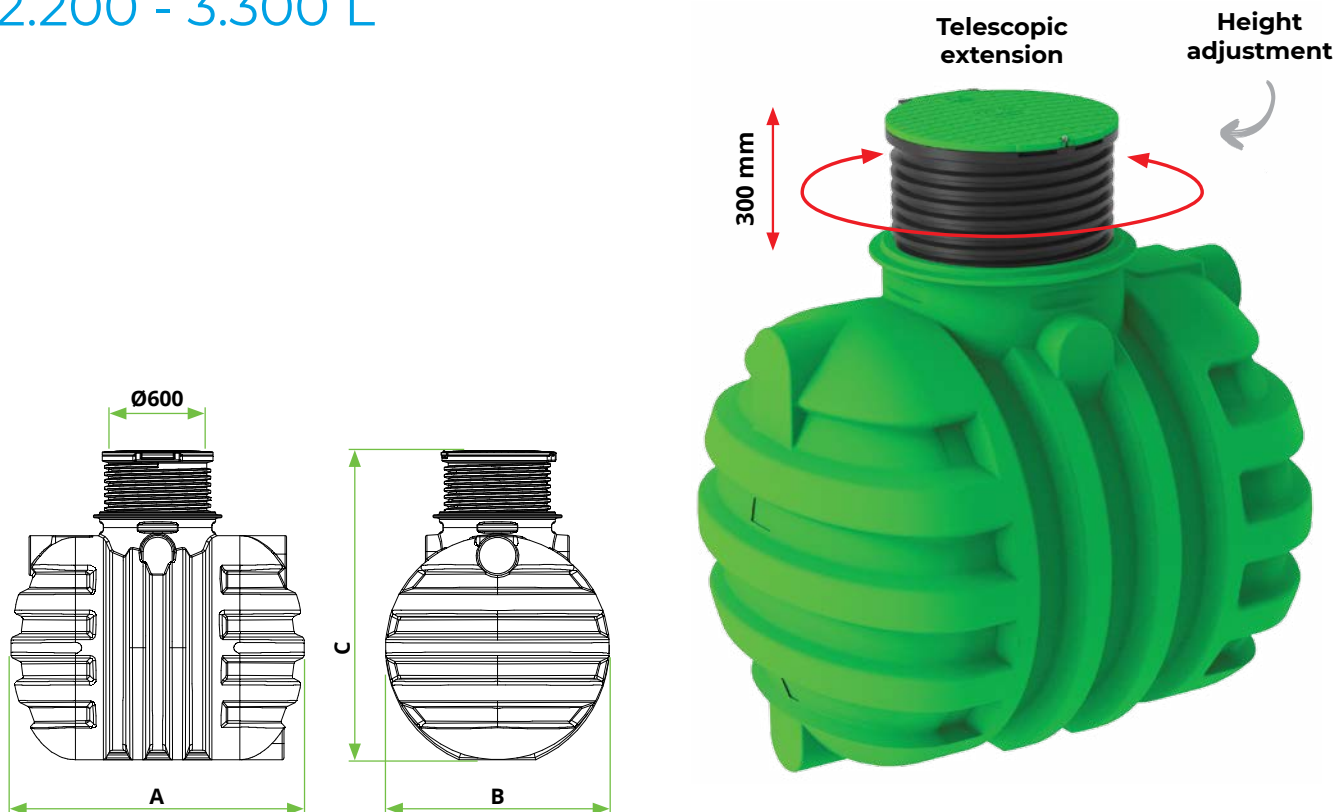

Volume [L]	Code	Dimensions A x B x C [mm]	Inspection opening [mm]	Weight [kg]
2.200	7100067160	1840 x 1400 x 1600 - 1900	Ø600	100
2.600	7100067180	2150 x 1400 x 1600 - 1900	Ø600	115
3.000	7100067170	2400 x 1400 x 1600 - 1900	Ø600	130
3.300	7100069480	2650 x 1400 x 1600 - 1900	Ø600	145

## Basic equipment:



**TELESCOPIC EXTENSION AND COVER WITH HINGED OPENING DN 600**  
[code: 7600088710]



Find **accessories**  
on the page 44

## Technical specifications:

<b>Technical approval:</b>	STS-15/0018
<b>CE (Mechanical resistance and stability):</b>	P 0865 / 12 - 680 - 2
<b>CE (Waterproofness):</b>	P 0865 / 12 - 680 - 1
<b>Maximum earth covering:</b>	700 mm
<b>Road surfaces:</b>	Required AB slab above the tank and cast iron cover
<b>High groundwater:</b>	Required ground AB slab and anchoring of the tank
<b>Connections:</b>	From DN 50 up to DN 160

# Roterra 1800

3.500 - 6.000 L

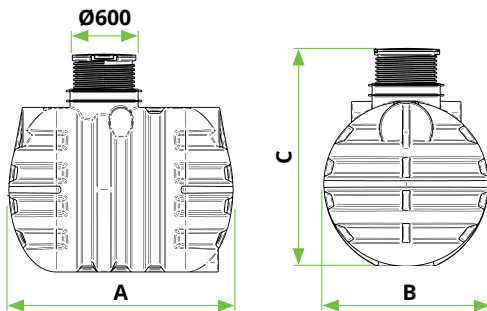
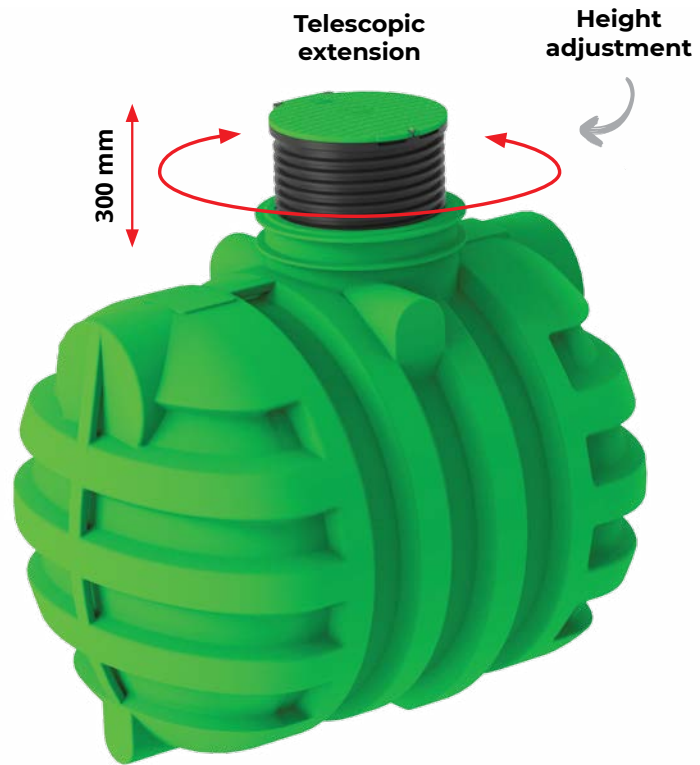

Volume [L]	Code	Dimensions A x B x C [mm]	Inspection opening [mm]	Weight [kg]
3.500	7100067120	2080 x 1800 x 2050 - 2350	Ø600	165
5.000	7100067130	2450 x 1800 x 2050 - 2350	Ø600	195
6.000	7100067140	2820 x 1800 x 2050 - 2350	Ø600	235

## Basic equipment:



TELESCOPIC EXTENSION AND COVER WITH  
HINGED OPENING DN 600  
[code: 7600088710]



Find **accessories**  
on the page 44

## Technical specifications:

Technical approval:	STS-15/0018
CE (Mechanical resistance and stability):	P 0865 / 12 - 680 - 2
CE (Waterproofness):	P 0865 / 12 - 680 - 1
Maximum earth covering:	700 mm
Road surfaces:	Required AB slab above the tank and cast iron cover
High groundwater:	Required ground AB slab and anchoring of the tank
Connections:	From DN 50 up to DN 400

# Roterra 2300

8.000 - 16.000 L

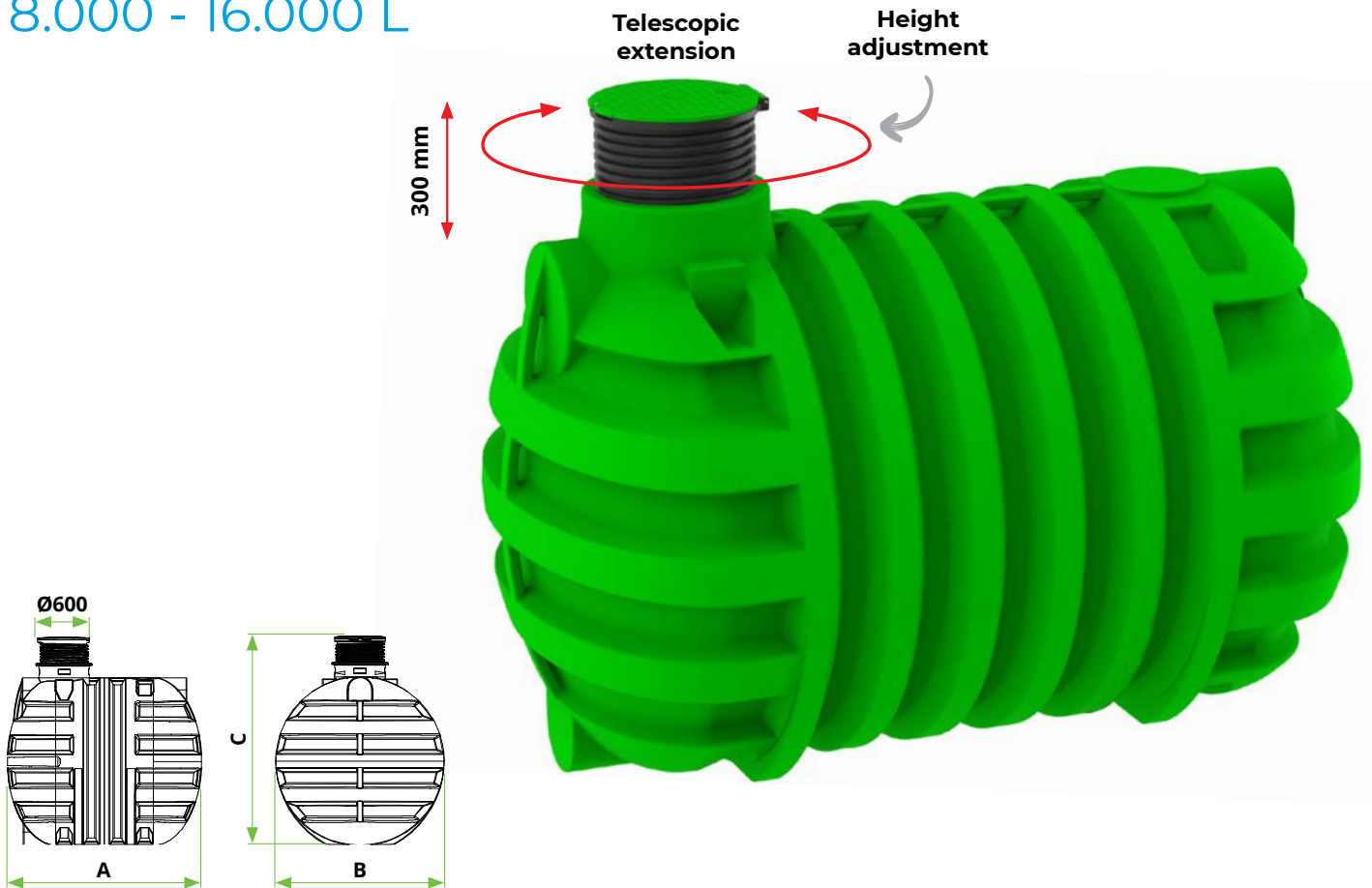

Volume [L]	Code	Dimensions A x B x C [mm]	Inspection opening [mm]	Weight [kg]
8.000	7100062540	2680 x 2300 x 2550 - 2850	Ø600	275
10.000	7100069030	3040 x 2300 x 2550 - 2850	Ø600	315
12.000	7100062500	3760 x 2300 x 2550 - 2850	Ø600	365
16.000	7100065770	4840 x 2300 x 2550 - 2850	Ø600	465

## Basic equipment:



**TELESCOPIC EXTENSION AND COVER WITH  
HINGED OPENING DN 600**  
[code: 7600088710]



Find **accessories**  
on the page 44

## Technical specifications:

<b>Technical approval:</b>	STS-15/0018
<b>CE (Mechanical resistance and stability):</b>	P 0865 / 12 - 680 - 2
<b>CE (Waterproofness):</b>	P 0865 / 12 - 680 - 1
<b>Maximum earth covering:</b>	700 mm
<b>Road surfaces:</b>	Required AB slab above the tank and cast iron cover
<b>High groundwater:</b>	Required ground AB slab and anchoring of the tank
<b>Connections:</b>	From DN 50 up to DN 400



VILLAGE



FACTORY



TOURIST RESORT



HOTEL RESORT



MILITARY BASE



FAMILY HOUSE



MOUNTAIN LODGE

# Roterra 2450

## COVER DN 600 WITH TELESCOPIC EXTENSION

The Roterra tank cover with gasket and hinged opening ensures effective water tightness. The loading capacity of the PE cover is up to 200 kg.

## DN 800 COVER OPTIONAL WITH ADDITIONAL ADAPTER

With an additional adapter, a DN 800 hinged cover can be installed.



POSSIBILITY OF CONNECTION

INFLOW

OUTFLOW

POSSIBILITY OF CONNECTION

## NEW DESIGN

The elliptical shape of the tank ensures excellent statics, and resistance to vertical soil and groundwater forces.

## INSTALLATION

The levelled bottom makes installation quick and easy. The new design requires less embankment material.

## Roterra 2450 water tank features:



Underground tank installation needed



Material: polyethylene



Excellent statics, resistance to earth pressures and external forces



Wall thickness 8 - 14 mm



Possibility to adjust the height of the extension to the requirements of the terrain



The product can be 100% recycled after use

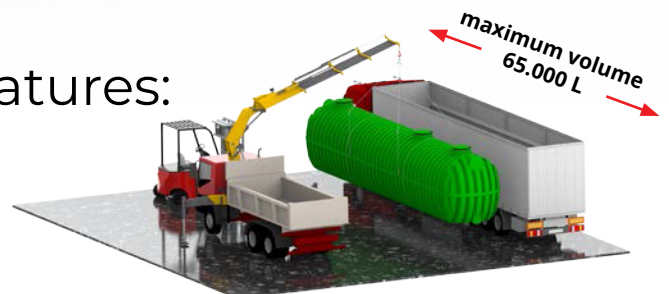

Up to 65,000 L can be transported with one truck

BASIC EQUIPMENT INCLUDES: telescopic extension and lid.

# Roterra 2450

22.000 - 30.000 L



The largest monolithic tank made in one piece by rotational moulding technology.

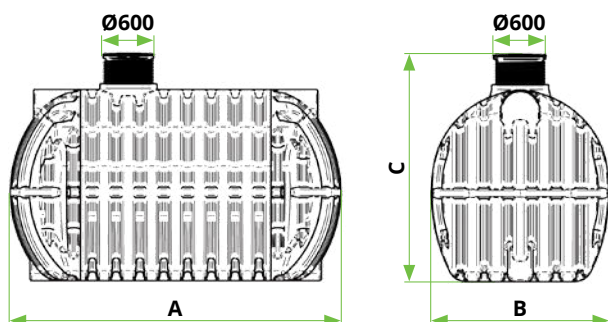
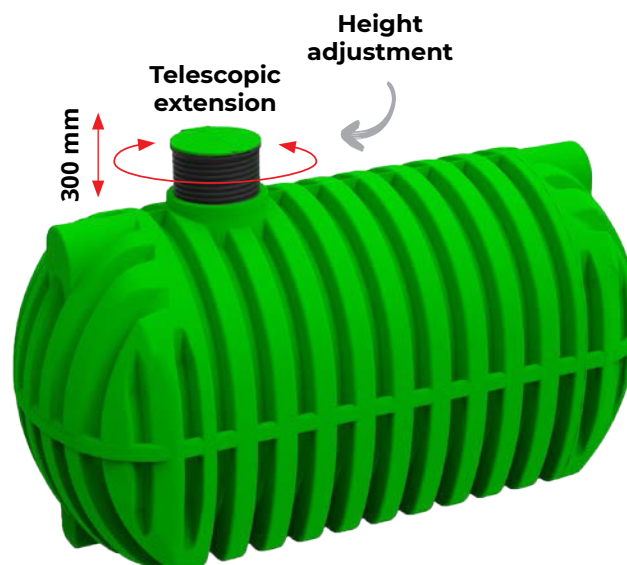

Volume [L]	Code	Dimensions A x B x C [mm]	Inspection opening [mm]	Weight [kg]
20.000	7100062670	4540 x 2450 x 2800 - 3100	Ø600	650
23.000	7100062680	5190 x 2450 x 2800 - 3100	Ø600	690

## Basic equipment:



TELESCOPIC EXTENSION AND COVER WITH HINGED OPENING DN 600  
[code: 7600088710]



Find **accessories** on the page 44

## Technical specifications:

Technical approval:	STS-15/0018
CE (Mechanical resistance and stability):	P 0865 / 12 - 680 - 2
CE (Waterproofness):	P 0865 / 12 - 680 - 1
Maximum earth covering:	700 mm
Road surfaces:	Required AB slab above the tank and cast iron cover
High groundwater:	Required ground AB slab and anchoring of the tank
Connections:	From DN 50 up to DN 400



# Roterra 2450

30.000 - 65.000 L

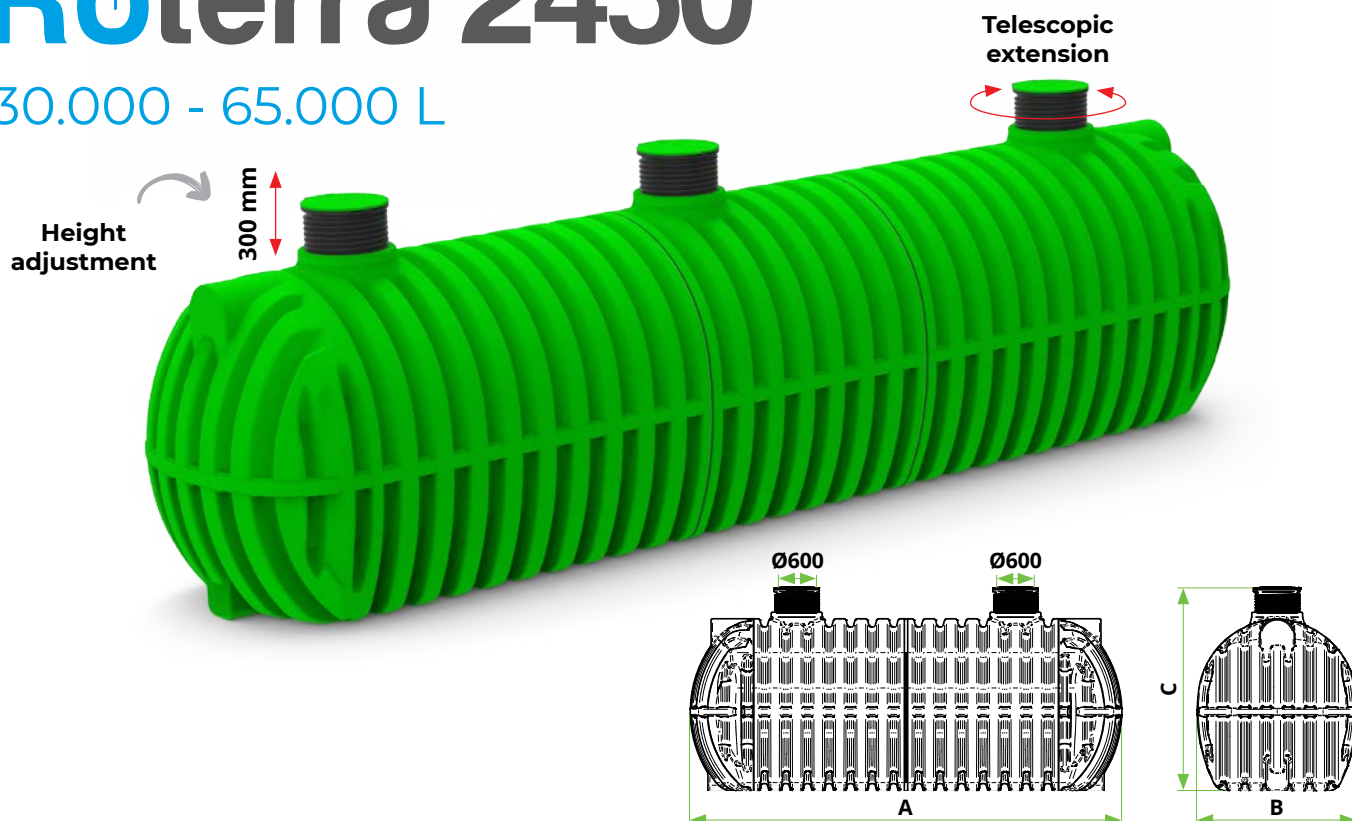

Volume [L]	Code	Dimensions A x B x C [mm]	Inspection opening [mm]	Weight [kg]
30.000	7110030000	6550 x 2425 x 2700 - 3000	2 x Ø600	990
35.000	7110035000	7530 x 2425 x 2700 - 3000	2 x Ø600	1140
40.000	7110040000	8510 x 2425 x 2700 - 3000	2 x Ø600	1290
45.000	7110045000	9870 x 2425 x 2700 - 3000	3 x Ø600	1560
50.000	7110050000	10850 x 2425 x 2700 - 3000	3 x Ø600	1700
55.000	7110055000	11500 x 2425 x 2700 - 3000	3 x Ø600	1770
60.000	7110060000	12480 x 2425 x 2700 - 3000	3 x Ø600	1920
65.000	7110065000	13460 x 2425 x 2700 - 3000	3 x Ø600	2070

## Basic equipment:



**TELESCOPIC EXTENSION AND COVER WITH  
HINGED OPENING DN 600**  
[code: 7600088710]



Find **accessories**  
on the page 44

## Technical specifications:

<b>Technical approval:</b>	STS-15/0018
<b>CE (Mechanical resistance and stability):</b>	P 0865 / 12 - 680 - 2
<b>CE (Waterproofness):</b>	P 0865 / 12 - 680 - 1
<b>Maximum earth covering:</b>	700 mm
<b>Road surfaces:</b>	Required AB slab above the tank and cast iron cover
<b>High groundwater:</b>	Required ground AB slab and anchoring of the tank
<b>Connections:</b>	From DN 50 up to DN 400

## Roterra professional fire water systems

ROTO Roterra water tanks are also suitable for the preparation of fire water systems. The professional system complies with DIN 14230. We offer you standard equipment for universal solutions or custom-made equipment that is tailored to the client's project.

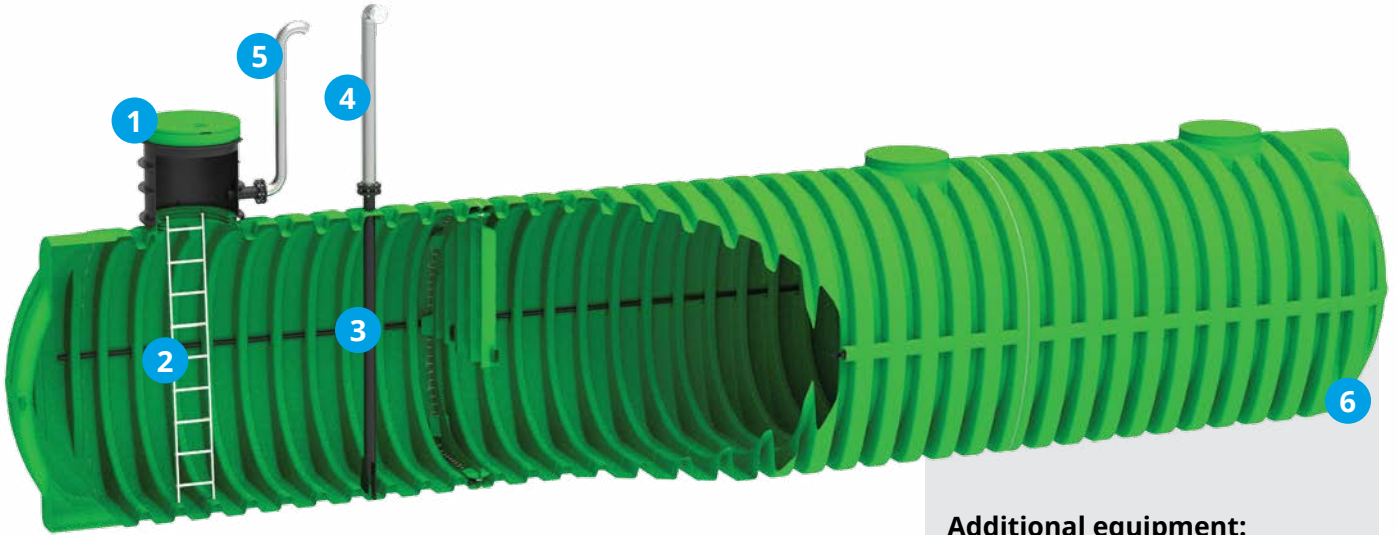

### Additional equipment:

1. inspection opening DN 1000 or DN 800
2. stainless steel ladder
3. suction hose up to DN 250 (including anti-vortex plate) - PE or stainless steel
4. connection for fire hose - coupling type A
5. ventilation pipe up to DN 160 (PE or stainless steel)
6. PE inlet / outlet connection

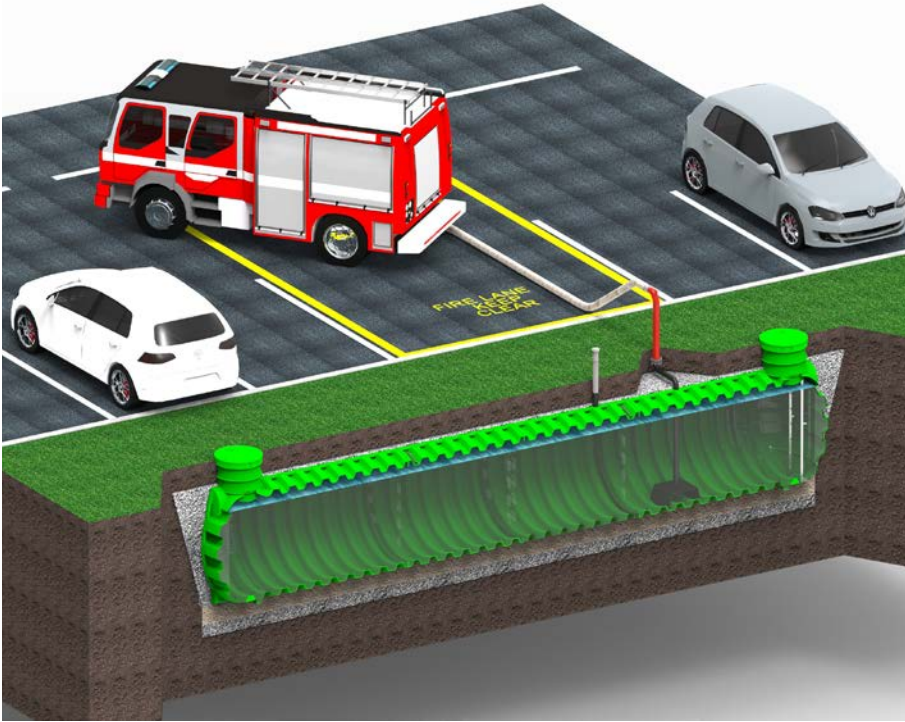



DHL LOGISTICS CENTER, AUSTRIA  
2x ROTERRA 50.000 L



FUEL STATION, SLOVENIA  
2x ROTERRA 50.000 L



WAREHOUSE, GERMANY  
8x ROTERRA 50.000 L



FACTORY, SLOVENIA  
2x ROTERRA 40.000 L





## Rainwater collecting

Did you know that the average water consumption per person is about 130 litres per day?

Only 2% of a household's drinking water is used for cooking and drinking, while rainwater can be used for all other needs.

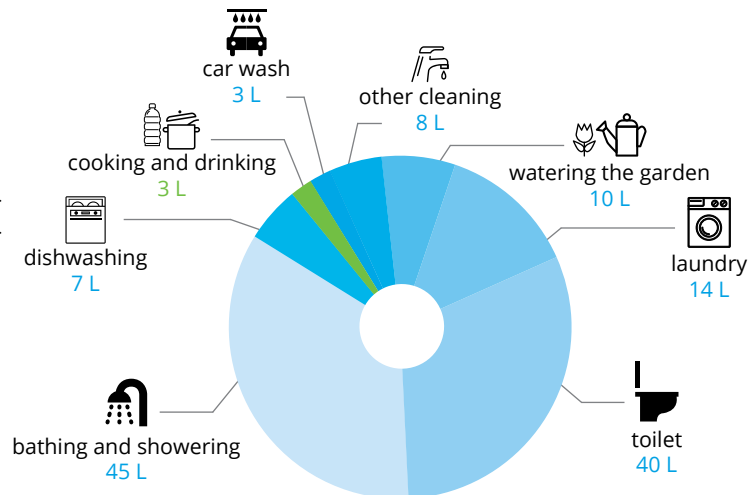

Did you know that **98 %** of water can be replaced by the rainwater?

## Benefits of using **ROTO** rainwater collecting system



### Independed souce of water

Rainwater harvesting helps utilities reduce peak demands during summer months, saving treated water for more important and appropriate water uses.



### As rainwater is soft

Compared to mains water which is known to be harder you won't need to buy clothing softeners to put in your wash and it won't cause limescale to build up in your washing machine, therefore reducing the risk of your appliance breaking down due to a build-up of limescale.



### Reduce water bills

It is cost-effective. The rainwater that falls on your roof and property is essentially free.



### Protect properties from flood damage

With the climate change, rainwater harvesting and proper rainwater management is crucial in order to alleviate risks of floods and droughts, reduce pressure on sewer networks and sewage treatment plants in cases of high precipitation.



### Can improve plant grow

It is an excellent source of water for plants and landscape irrigation since it has no chemicals such as fluoride and chloramines (chlorine).



### ENVIRONMENTAL PROTECTION

Rainwater collecting helps to protect the environment by reducing the consumption of drinking water.



## How to select the right water tank for your home?

### Step 1: Find out how much rain you can expect

Some areas get more rainfall than others. Knowing your pattern of rainfall gives you an idea of how much rain you can reasonably expect.

### Step 2: Calculate your rainwater harvesting capacity

Each square metre of roof area collects 1 litre of water for every 1 millimetre of rainfall received. For example, if your roof area is 200 m<sup>2</sup>, you can expect to harvest 100.000 L of rain for every 500 mm of rain. To calculate your roof surface area, multiply its length by its width. Then multiply this number by your area's average rainfall. That's your rainwater harvesting capacity.

### Step 3: Work out how much water you'll need

This involves thinking about what you will be using your collected water for.

Will you just be using it for the garden? If so, how big is your garden and how many times a week do you water it? Garden water use varies from 25 % to 50 % of household water. To maintain your lush green garden during summer's dry months, you'll need at least a 4.000 - 5.000 L tank.

What about the laundry and bathroom? How big is your family, and how much water do they use for the shower? How much water is used for washing clothes each week?

A toilet can use up to 12 L of water per flush, with the average person using 210 L of water per week just on the loo! Washing machines are also water guzzlers, and can use 50 L - 150 L of water per load depending on their efficiency levels.

### Step 4: Decide on your tank size

After bringing your calculations from steps 1-3 together, you should have a good idea of how much rainwater you can expect to collect for your area and roof size, as well as how much water your household needs.

Working out how big your tank needs to be is done by calculating the amount of water caught by the number of times your tank will fill each year. We recommend choosing a size that will hold a minimum of 4 weeks' supply.

### Step 5: Choose your tank's location

The best place to put your water tank is next to a wall or fence, as long as it doesn't block any doors or paths. Your tank location needs to be a sturdy, level surface, as rainwater tanks can weigh several tonnes when they're full. Install an underground water tank, as it is the ultimate space saver. You will need a water pump to get the water up and out of the tank for your household use.

## Pumps for water use in the garden or in the house



## Garden set

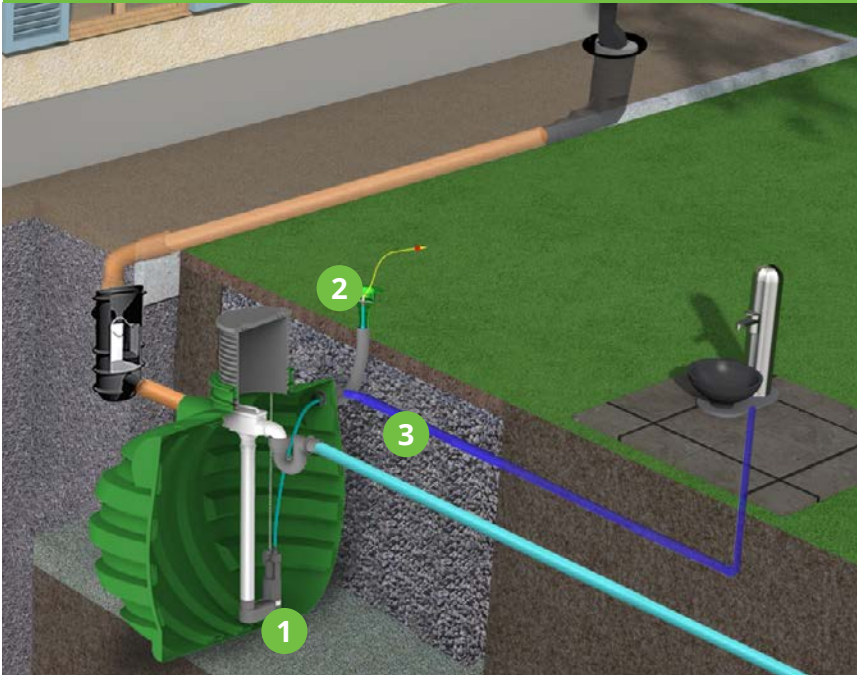

## THE SET INCLUDES:

1. Submersible pump with integrated pressure switch and pressure sensor **DAB Diversion 1000** (max flow: 5.7 m<sup>3</sup>/h; maximum pumping height: 36 m; input power: 900 W; weight: 11 kg, 7 m power cable),
2. a garden mini-trough on which a watering hose can be attached,
3. pressure pipe between the pump and the inspection window.



## House set

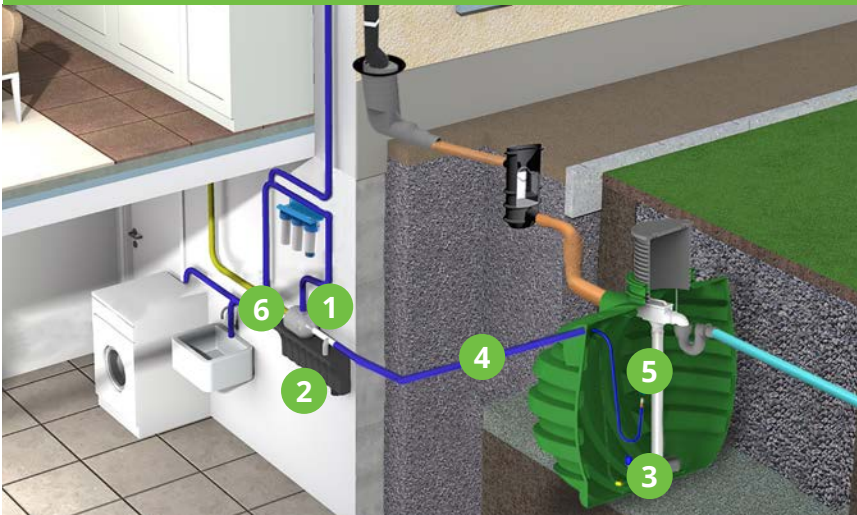

## THE SET INCLUDES:

1. Household pump set **Grundfos** (max flow: 3 m<sup>3</sup>/h; maximum pumping height: 15 m; maximum service pressure: 7,5 bar; input power: 660 W)
2. storage tank (used for system security purposes, so the water distribution network is not burdened),
3. a float switch fitted with a 15 m cable,
4. 15 m vacuuming tube with a float bleed,
5. stainless filter and non-returning valve,
6. mixing valve.



The House Kit is a fully automated system that makes sure rainwater can be used in the house and garden; for the toilet, dishwasher, washing machine, car washing and more.

The House Kit is a pre-prepared pumping system ready for connection to the building. The system works by switching between two sources of water—the rainwater collected in the reservoir and the public pipeline – using a solenoid valve. It gives priority to rainwater, but when the reservoir runs out of water, the system chooses the public network. The House Kit is also upgraded with a small tank, which serves as an intermediate link, as the public network is not allowed to be directly loaded by pressure pumps. The pump is water-cooled, so it runs much quieter than air-cooled pumps.



**Roterra** water tanks can be connected in series or in parallel to increase the volume capacity of the whole system. Such systems are particularly useful for storing fire water near

buildings, as water storage for irrigation systems or as water storage for settlements. Joints can be made in two ways, either by flange joints or by electrofusion welding.



Connect sequential

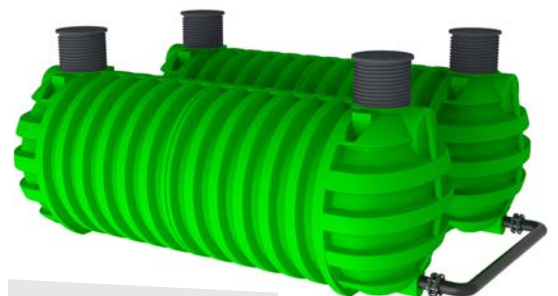

Connect parallel

## Flange joint



The pipes between tanks can be joined using flanged joints. The company prepares the joining elements (flanges, end caps, seals) on the tanks. The joint is then bolted on site and can be done by the user.



## Electrofusion welding



The tanks can also be connected to each other using polyethylene pipes (PE 100), which are joined together using an electrofusion welding process. Depending on how the tank is arranged (parallel or in series), different electrofusion elements are used in electrofusion welding, such as EF couplings and EF elbows. The electrofusion welding itself is carried out on site and requires welding equipment.



## Connection **size table**

Water tank type	Connector mounting location	Inlet rubber washer	Welded pipe for connection
RoTerra 1400 from 2.200 up to 3.300 L	upper	up to DN 110	up to DN 200
	lower	/	up to DN 150
RoTerra 1800 from 3.500 up to 6.000 L	upper	up to DN 150	up to DN 300
	lower	/	up to DN 150
RoTerra 2300 from 8.000 up to 30.000 L	upper	up to DN 200	up to DN 300
	lower		up to DN 300
RoTerra 2450 from 30.000 up to 65.000 L	upper	up to DN 300	up to DN 500
	lower	/	up to DN 300





**DRINKING WATER SYSTEMS**

# Rodrink

## PE COVER WITH ADAPTER

The cover with gasket and hinged opening ensures effective water tightness. The loading capacity of the PE DN 600 cover is up to 200 kg.

## INTEGRATED EXTENSION

Integrated extension allows quick and easy adjustment of the height when digging.

## POSSIBILITY OF CONNECTION

### INFLOW

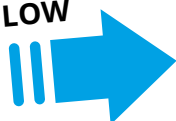

### OUTFLOW

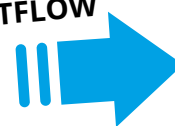

## REINFORCING RIBS

Reinforcing ribs on both sides ensure the stability of the tank and protection in case of high water tables.

## POSSIBILITY OF CONNECTION

## INSTALLATION

The levelled base makes installation quick and easy.

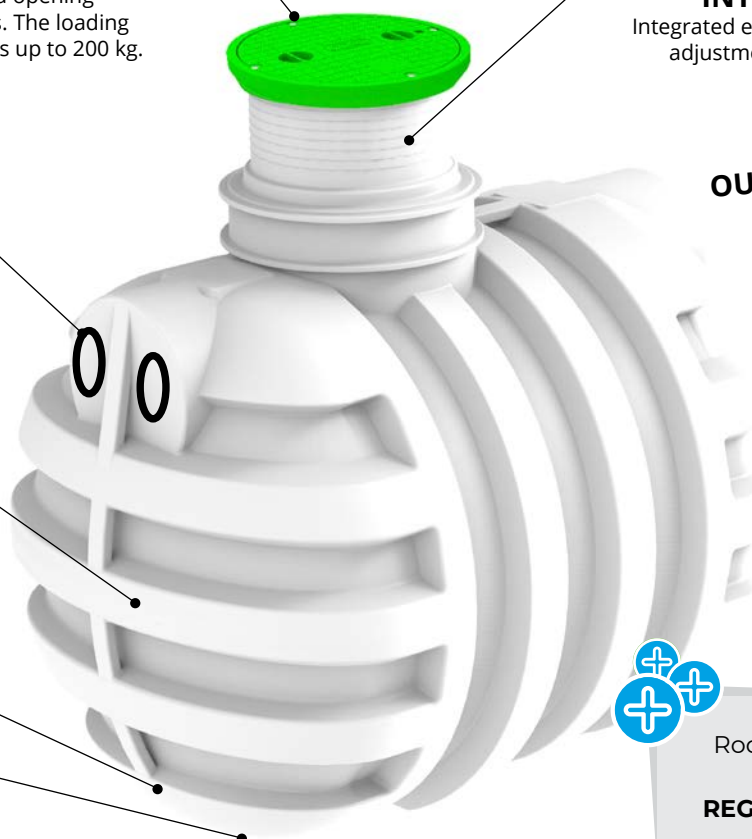

Rodrink tanks are certified for drinking water:  
**REG2-0004-04-ZGPro1-2731**

## Rodrink water tank features:



Underground tank installation needed



Material: polyethylene



Made in one piece, 100% waterproof



With a certificate for drinking water storage



Excellent statics, resistance to earth pressures and external forces



Wall thickness 8 - 14 mm



Possibility to adjust the height of the extension to the requirements of the terrain



The product can be 100% recycled after use

BASIC EQUIPMENT INCLUDES: hinged cover with adapter.

# Rodrink

## 2.200 - 6.000 L

Possibility of adjustment



-300 mm

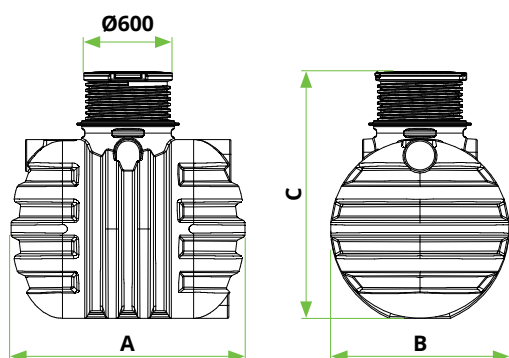

Volume [L]	Code	Dimensions A x B x C [mm]	Inspection opening [mm]	Weight [kg]
2.200	7100067161	1840 x 1400 x 1600	Ø600	100
3.000	7100067171	2400 x 1400 x 1600	Ø600	130
5.000	7100090411	2450 x 1800 x 2050	Ø600	195
6.000	7100090421	2820 x 1800 x 2050	Ø600	235

### Basic equipment:



**COVER DN 600  
WITH ADAPTER, ASSEMBLED**  
[code: 7100520240]



Find **accessories**  
on the page 44

### Technical specifications:

<b>Drinking water certificate:</b>	REG2-0004-04-ZGPro1-2731
<b>CE (Mechanical resistance and stability):</b>	P 0865 / 12 - 680 - 2
<b>CE (Waterproofness):</b>	P 0865 / 12 - 680 - 1
<b>Maximum earth covering:</b>	700 mm
<b>Road surfaces:</b>	Required AB slab above the tank and cast iron cover
<b>High groundwater:</b>	Required ground AB slab and anchoring of the tank
<b>Connections:</b>	From DN 50 up to DN 400

# Rodrink

## 8.000 - 16.000 L

Possibility of adjustment

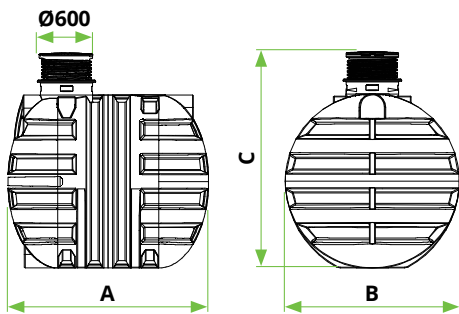

Volume [L]	Code	Dimensions A x B x C [mm]	Inspection opening [mm]	Weight [kg]
8.000	7100062541	2680 x 2300 x 2350	Ø600	275
10.000	7100069031	3040 x 2300 x 2350	Ø600	315
12.000	7100062501	3760 x 2300 x 2350	Ø600	365
16.000	7100065771	4840 x 2300 x 2350	Ø600	465

### Basic equipment:



**COVER DN 600  
WITH ADAPTER, ASSEMBLED**  
[code: 7100520240]



Find **accessories**  
on the page 44

### Technical specifications:

<b>Drinking water certificate:</b>	REG2-0004-04-ZGPro1-2731
<b>CE (Mechanical resistance and stability):</b>	P 0865 / 12 - 680 - 2
<b>CE (Waterproofness):</b>	P 0865 / 12 - 680 - 1
<b>Maximum earth covering:</b>	700 mm
<b>Road surfaces:</b>	Required AB slab above the tank and cast iron cover
<b>High groundwater:</b>	Required ground AB slab and anchoring of the tank
<b>Connections:</b>	From DN 50 up to DN 400

# Rodrink

22.000 - 30.000 L



Volume [L]	Code	Dimensions A x B x C [mm]	Inspection opening [mm]	Weight [kg]
22.000	7100062571	6280 x 2300 x 2850	2 x Ø600	820
25.000	7100862571	7370 x 2300 x 2850	2 x Ø600	1040
30.000	7100062351	8450 x 2300 x 2850	2 x Ø600	1080

## Basic equipment:



**COVER DN 600 WITH ADAPTER, ASSEMBLED**  
[code: 7100520240]

**+** Find accessories on the page 44

## Technical specifications:

<b>Drinking water certificate:</b>	REG2-0004-04-ZGPro1-2731
<b>CE (Mechanical resistance and stability):</b>	P 0865 / 12 - 680 - 2
<b>CE (Waterproofness):</b>	P 0865 / 12 - 680 - 1
<b>Maximum earth covering:</b>	700 mm
<b>Road surfaces:</b>	Required AB slab above the tank and cast iron cover
<b>High groundwater:</b>	Required ground AB slab and anchoring of the tank
<b>Connections:</b>	From DN 50 up to DN 400

# Rodrink 2450

30.000 - 65.000 L

Possibility of adjustment



-300 mm

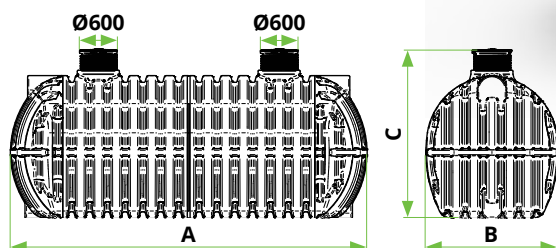
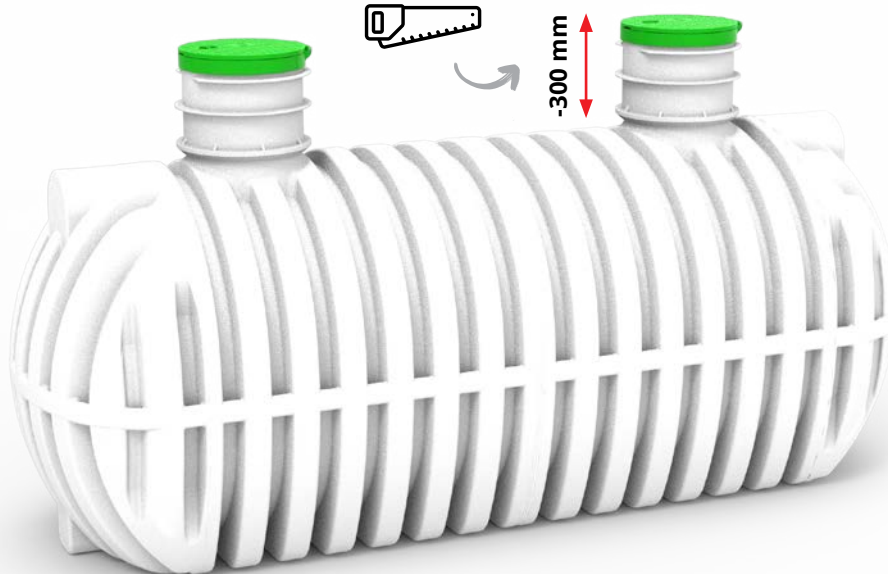

Volume [L]	Code	Dimensions A x B x C [mm]	Inspection opening [mm]	Weight [kg]
30.000	7110030000	6550 x 2425 x 2700 - 3000	2 x Ø800	990
35.000	7110035000	7530 x 2425 x 2700 - 3000	2 x Ø800	1140
40.000	710040000	8510 x 2425 x 2700 - 3000	2 x Ø800	1290
45.000	7110045000	9870 x 2425 x 2700 - 3000	3 x Ø800	1560
50.000	7110050000	10850 x 2425 x 2700 - 3000	3 x Ø800	1700
55.000	7110055000	11500 x 2425 x 2700 - 3000	3 x Ø800	1770
60.000	7110060000	12480 x 2425 x 2700 - 3000	3 x Ø800	1920
65.000	7110065000	13460 x 2425 x 2700 - 3000	3 x Ø800	2070

## Basic equipment:



**COVER DN 800  
WITH ADAPTER, ASSEMBLED**  
[code: 7100520620]



Find **accessories**  
on the page 44

## Technical specifications:

<b>Drinking water certificate:</b>	REG2-0004-04-ZGPro1-2731
<b>Mechanical resistance and stability:</b>	P 0865 / 12 - 680 - 2
<b>Waterproof:</b>	P 0865 / 12 - 680 - 1
<b>Maximum earth covering:</b>	700 mm
<b>Road surfaces:</b>	Required AB slab above the tank and cast iron cover
<b>High groundwater:</b>	Required ground AB slab and anchoring of the tank
<b>Connections:</b>	From DN 50 up to DN 400



**WATER TANKS - VERTICAL**

# Rocko

## PE COVER WITH ADAPTER

The cover with gasket and hinged opening ensures effective water tightness. The load capacity of the PE DN 600 cover is up to 200 kg.

## PE RING

It allows easy installation of an additional tank extension and thus easy adjustment to the terrain.

## INTEGRATED EXTENSION

The extension of the ROTO Rocko tanks can be cut off so that the height can be adjusted to the terrain.

INFLOW



OUTFLOW

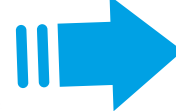

POSSIBILITY OF CONNECTION

## HOLES FOR ANCHORING

They make it easier to attach tank to a concrete slab in case of anchoring due to high groundwater.

## REINFORCING RIBS

Reinforcing ribs on both sides ensure the stability of the tank and protection in case of high water tables.



Rocko tanks can be used as an **UNDERGROUND** or **OVERGROUND** water tank.

## Rocko water tank features:



Underground OR  
overground water tank



Material:  
polyethylene



Made in one piece,  
100% waterproof



Excellent statics, resistance  
to earth pressures and  
external forces

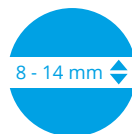

Wall thickness  
8 - 14 mm



Possibility to adjust the  
height of the extension to the  
requirements of the terrain



The product can be  
100% recycled after use

BASIC EQUIPMENT INCLUDES: hinged cover with adapter.

# Rocko Ø1300

1.200 - 3.000 L

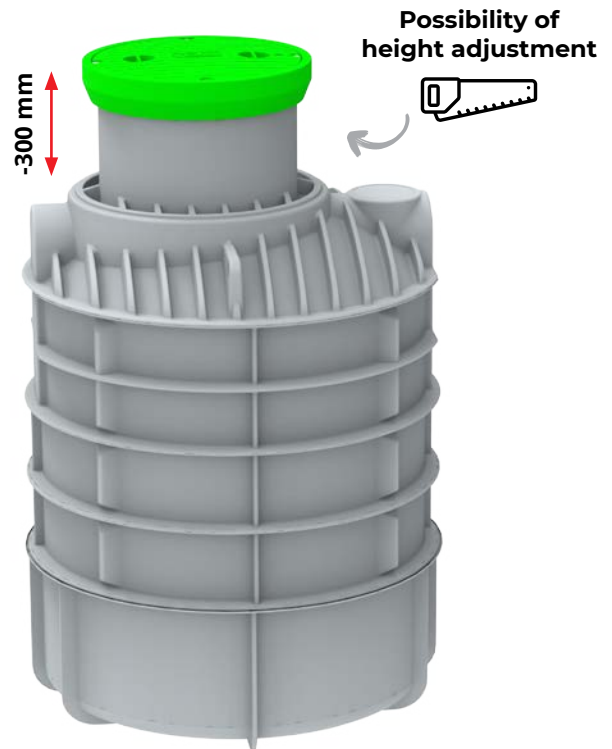
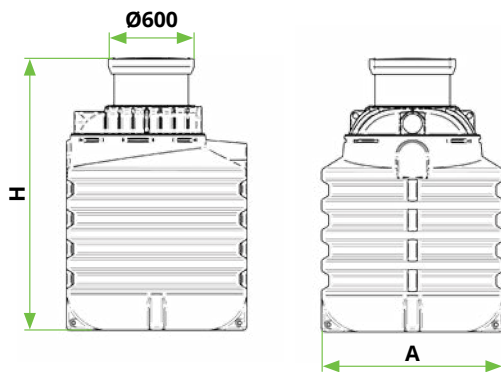

Volume [L]	Code	Dimensions A x B x C [mm]	Inspection opening [mm]	Weight [kg]
1.200	7100057620	Ø1300 x 1550	Ø600/800	50
1.500	7100057630	Ø1300 x 1800	Ø600/800	65
1.700	7100057810	Ø1300 x 2050	Ø600/800	80
2.000	7100057640	Ø1300 x 2300	Ø600/800	95
2.300	7100057650	Ø1300 x 2550	Ø600/800	115
2.500	7100057840	Ø1300 x 2800	Ø600/800	130
2.800	7100057660	Ø1300 x 3050	Ø600/800	145
3.000	7100057860	Ø1300 x 3300	Ø600/800	160

## Basic equipment:



**COVER DN 600  
WITH ADAPTER, ASSEMBLED**  
[code: 7100520240]



Find **accessories**  
on the page 44

## Technical specifications:

<b>Load capacity on vertical load:</b>	P 0087/17-680-2
<b>Waterproof:</b>	P 0087/17-680-1
<b>Maximum earth covering:</b>	540 mm
<b>Road surfaces:</b>	Required AB slab above the tank and cast iron cover
<b>High groundwater:</b>	Required ground AB slab and anchoring of the tank
<b>Connections:</b>	From DN 50 up to DN 160

# Rocko Ø1500

2.000 - 2.700 L

Possibility of height adjustment

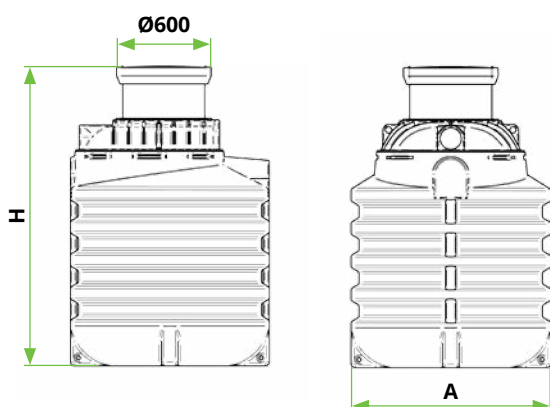
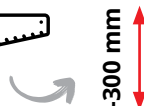

Volume [L]	Code	Dimensions A x B x C [mm]	Inspection opening [mm]	Weight [kg]
2.000	7100067450	Ø1500 x 2000	Ø600	79
2.350	7100067460	Ø1500 x 2250	Ø600	90
2.700	7100067470	Ø1500 x 2500	Ø600	101

## Basic equipment:



**COVER DN 600  
WITH ADAPTER, ASSEMBLED**  
[code: 7100520240]



Find **accessories**  
on the page 44

## Technical specifications:

<b>Load capacity on vertical load:</b>	P 0087/17-680-2
<b>Waterproof:</b>	P 0087/17-680-1
<b>Maximum earth covering:</b>	540 mm
<b>Road surfaces:</b>	Required AB slab above the tank and cast iron cover
<b>High groundwater:</b>	Required ground AB slab and anchoring of the tank
<b>Connections:</b>	From DN 50 up to DN 160

# Rocko Ø1800

3.200 - 5.000 L

Possibility of height adjustment



-300 mm

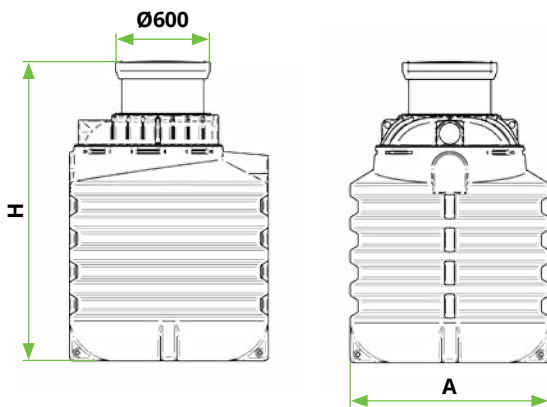

Volume [L]	Code	Dimensions A x B x C [mm]	Inspection opening [mm]	Weight [kg]
3.200	7100067260	Ø1800 x 2350	Ø800	136
4.000	7100067270	Ø1800 x 2700	Ø800	155
5.000	7100067280	Ø1800 x 3100	Ø800	182

## Basic equipment:



**COVER DN 600  
WITH ADAPTER, ASSEMBLED**  
[code: 7100520240]



Find **accessories**  
on the page 44

## Technical specifications:

<b>Load capacity on vertical load:</b>	P 0087/17-680-2
<b>Waterproof:</b>	P 0087/17-680-1
<b>Maximum earth covering:</b>	540 mm
<b>Road surfaces:</b>	Required AB slab above the tank and cast iron cover
<b>High groundwater:</b>	Required ground AB slab and anchoring of the tank
<b>Connections:</b>	From DN 50 up to DN 160

# Rocko Ø2300

6.000 - 10.000 L

Possibility of height adjustment



-300 mm

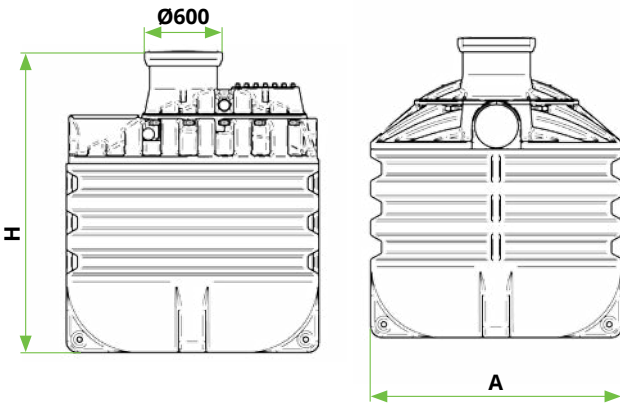

Volume [L]	Code	Dimensions A x B x C [mm]	Inspection opening [mm]	Weight [kg]
6.000	7100067340	Ø2300 x 2400	1 x Ø800 or 2 x Ø600	221
7.500	7100067350	Ø2300 x 2750	1 x Ø800 or 2 x Ø600	252
8.700	7100067360	Ø2300 x 3100	1 x Ø800 or 2 x Ø600	283
10.000	7100067370	Ø2300 x 3500	1 x Ø800 or 2 x Ø600	315

## Basic equipment:



**COVER DN 600 WITH ADAPTER, ASSEMBLED**  
[code: 7100520240]

## Technical specifications:

<b>Load capacity on vertical load:</b>	P 0087/17-680-2
<b>Waterproof:</b>	P 0087/17-680-1
<b>Maximum earth covering:</b>	540 mm
<b>Road surfaces:</b>	Required AB slab above the tank and cast iron cover
<b>High groundwater:</b>	Required ground AB slab and anchoring of the tank
<b>Connections:</b>	From DN 50 up to DN 160

**+** Find accessories on the page 44





**WATER TANKS - FLAT**

# Robox 5000

## 5.000 L

### HINGED COVER

The Roterra tank lid with gasket ensures water tightness. The lid is hinged to the telescopic extension, making it easy to open.

### TELESCOPIC EXTENSION

The telescopic extension is shaped like a screw. This mode allows quick and easy adjustment of the height when digging. The dimensions of the extension are  $\varnothing 600 \times 400$  mm.

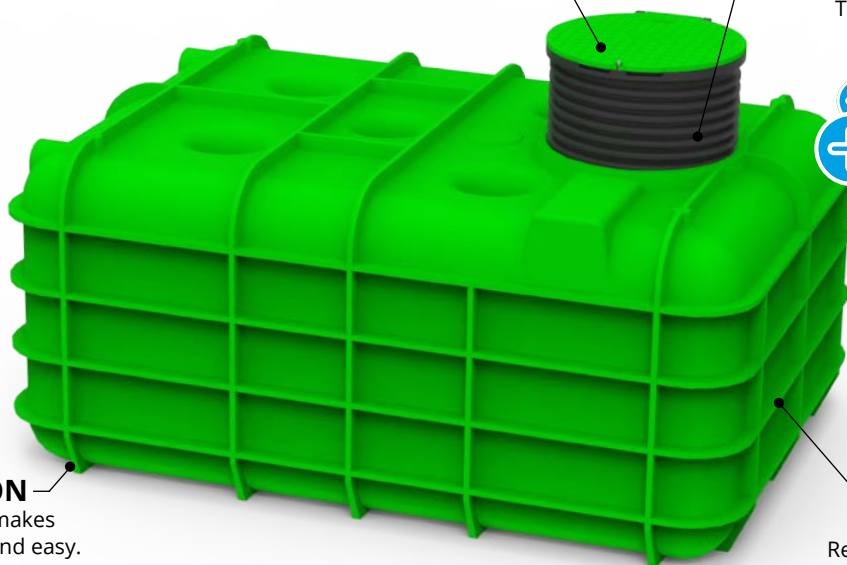

Up to 14 tanks can be transported at the same time with a semi-trailer.



### INSTALLATION

The levelled base makes installation quick and easy.

### REINFORCING RIBS

Reinforcing ribs on both sides ensure the stability of the tank and protection in case of high water tables.



### THREADED ADAPTER FOR FINE FILTER

For quick and easy installation of a fine filter and soothing siphon. At the same time we achieve a slight increase in the volume of the tank. Available as additional equipment.

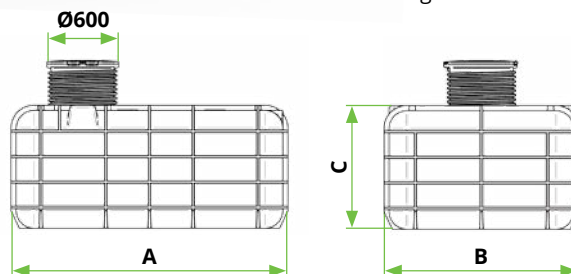
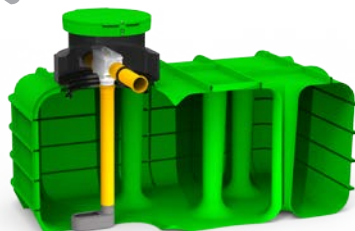

Volume [L]	Code	Dimensions A x B x C [mm]	Inspection opening [mm]	Weight [kg]
5.000	7100072290	2690 x 1890 x 1200	$\varnothing 600$	200

### Basic equipment:



TELESCOPIC EXTENSION AND COVER WITH HINGED OPENING DN 600  
[code: 7600088710]

### Technical specifications:

Load capacity on vertical load:	P 0850/16-680-1
Waterproof:	P 0850/16-680-2
Maximum earth covering:	600 mm
Connections:	From DN 50 up to DN 160



Find **accessories** on the page 44

# Rocko Ø2310

3.500 - 5.000 L

Plitvi rezervoarji za vodo **Rocko** so izdelani iz polietilena. So idealna izbira kadar nimamo možnosti globokega vkopa.

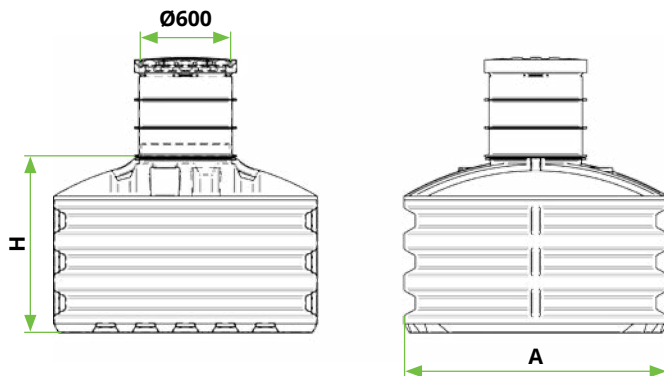

Tank suitable for shallow installation



Material: polyethylene



Made in one piece, 100% waterproof

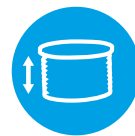

Possibility to adjust the height of the extension to the requirements of the terrain



The product can be 100% recycled after use

Volume [L]	Code	Dimensions A x B x C [mm]	Inspection opening [mm]	Weight [kg]
3.500	7100267030	Ø2310 x 1290 - 2020	Ø800	177
5.000	7100267070	Ø2310 x 1655 - 2390	Ø800	200

## Basic equipment:

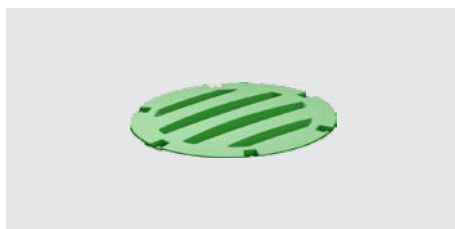

COVER DN 800,  
[code: 7100901810]

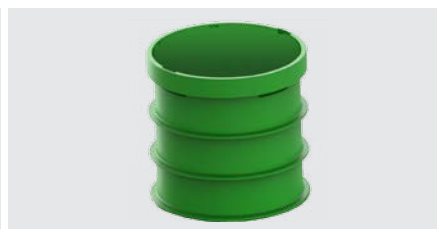

EXTENSION DN 800 x 750 mm  
[code: 7100067020]



Find **accessories** on the page 44

# RotoM

## 2.100 L

Flat water tanks **RotoM** are made of polyethylene. They are an ideal choice when there is no option of deep digging. Two versions available - horizontal or vertical tank.



RotoM vertical tank layout – suitable as a **OVERGROUND TANK**



RotoM tanks can be used as a **VERTICAL OVERGROUND** or **HORIZONTAL UNDERGROUND** tank.



Tank suitable for shallow installation



Material: polyethylene



Made in one piece, 100% waterproof



It can be used as a horizontal or vertical tank



The product can be 100% recycled after use

Volume [L]	Code	Dimensions A x B x C [mm]	Inspection opening [mm]	Weight [kg]
2.100 vertical	7100067200	2180 x 700 x 1725	Ø300	77
2.100 horizontal	7100067210	2180 x 1725 x 700	Ø300	90



**WATER TANKS - OVERGROUND**

# RoQuadro

250 - 2.000 L

Roquadro water tanks are made of polyethylene. They are the ideal choice for above-ground or basement tanks. Their dimensions make them **easy to transport through normal front doors** and they are also very suitable as an **outdoor rainwater collecting tank at the side of the house**.

They have the advantage of **extremely smooth walls for easy cleaning** and a flat bottom to ensure the stability of the tank. The lid is easily removed as it is screwed on.

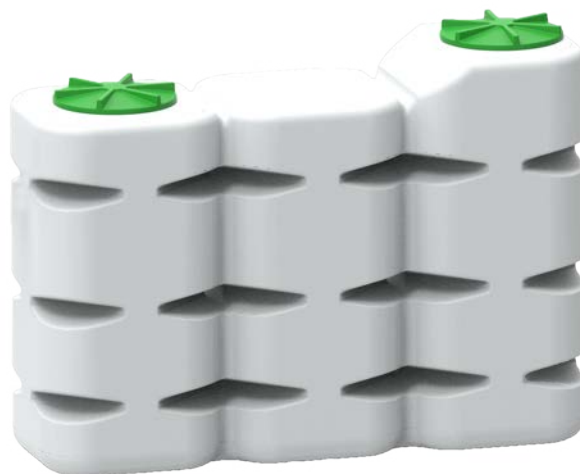

Volume [L]	Code	Dimensions A x B x C [mm]	Inspection opening [mm]	Weight [kg]
250	7104103260	600 x 600 x 928	Ø300	12
500	7104104060	760 x 760 x 1100	Ø300	23
750	7104106060	760 x 760 x 1600	Ø300	30
1.000	7104107660	760 x 1520 x 1100	Ø300	45
2.000	7104109460	760 x 2250 x 1600	Ø300	80

# Roto OTW

**OTW and RotoM** water tanks are made of polyethylene and are therefore suitable for water storage. They are the ideal choice for aboveground or basement tanks. A tap can be installed at the bottom.



Volume [L]	Code	Dimensions A x B x C [mm]	Inspection opening [mm]	Weight [kg]
60	7101511710	430 x 320 x 510	Ø240	4,5
100	7101511870	480 x 340 x 630	Ø240	5
150	7101511750	660 x 440 x 700	Ø240	8
200	7101511770	760 x 480 x 800	Ø240	9
300	7101511800	940 x 500 x 880	Ø240	15
500	7101518830	1300 x 580 x 930	Ø240	25

# RotoM



Volume [L]	Code	Dimensions A x B x C [mm]	Inspection opening [mm]	Total weight [kg]
500	7100065780	1200 x 570 x 1100	Ø240	15
1.000	7100065800	1570 x 650 x 1240	Ø240	35
1.500	7100065900	1850 x 720 x 1550	Ø240	45



# Rondo

## 325 - 15.000 L

**Rondo** water tanks are made of polyethylene. They are the ideal choice for above-ground or basement tanks.



Volume [L]	Code	Dimensions A x B x C [mm]	Inspection opening [mm]	Weight [kg]
325	7100527300	Ø620 x 1300	Ø200	12
500	7100527310	Ø740 x 1350	Ø300	26
800	7100527320	Ø840 x 1600	Ø500	30
1.000	7100527330	Ø950 x 1650	Ø300	34
1.500	7100527340	Ø1100 x 1850	Ø300	40
2.000	7100527350	Ø1200 x 1950	Ø380	60
3.000	7100527400	Ø1860 x 1430	Ø435	65
4.000	7100527410	Ø1860 x 1920	Ø435	75
5.000	7100077620	Ø1585 x 2825	Ø370	160
6.000	7100527420	Ø1860 x 2590	Ø435	125
8.000	7100527430	Ø2460 x 2020	Ø635	140
10.000	7100527440	Ø2460 x 2470	Ø635	220
15.000	7100527450	Ø2460 x 3620	Ø635	430

# Rotrans









## 300 - 5.000 L

**Rotrans** water tanks are made of polyethylene and are therefore suitable for storing water. They are the ideal choice for above-ground storage and transport of liquids.

Volume [L]	Code	Dimensions A x B x C [mm]	Inspection opening [mm]	Weight [kg]
300	7100527200	1220 x 590 x 660	Ø435	13
500	7100527210	1440 x 680 x 820	Ø435	17
1.000	7100527220	1730 x 870 x 1010	Ø435	28
1.500	7100527230	1610 x 1180 x 1310	Ø435	35
2.000	7100527240	1720 x 1250 x 1400	Ø435	47
3.000	7100527250	2030 x 1430 x 1600	Ø435	67
5.000	7100527260	2150 x 1840 x 1960	Ø435	130



## COVERS AND EXTENSIONS

IMAGE	NAME AND CODE	DESCRIPTION	SUITABLE FOR
	<b>COVER DN 400</b> [code: 7100061710]	Cover made of PE material, load capacity up to 2 kN, dimensions Ø400 x 100 mm	<b>RoOki 500 L</b> <b>RoOki 1.000 L</b>
	<b>EXTENSION Ø400 x 200 mm</b> [code: 7100063580]	Extension made of PE material, dimensions Ø400 x 200 mm	<b>RoOki 500 L</b> <b>RoOki 1.000 L</b>
	<b>COVER DN 500</b> [code: 7104111660]	Cover made of PE material, load capacity up to 2 kN, dimensions Ø500 x 80 mm	<b>RoOki 1.500 L</b> <b>RoOki 3.500 L</b>
	<b>EXTENSION Ø500 x 315 mm</b> [code: 7104036060]	Extension made of PE material, dimensions Ø500 x 315 mm	<b>RoOki 1.500 L</b> <b>RoOki 3.500 L</b>
	<b>COVER DN 600</b> [code: 7100520610]	Cover made of PE material, load capacity up to 2 kN, dimension Ø600 mm	<b>RoOki 3.000 L</b> <b>RoOki 5.000 L</b> <b>RoOki 10.000 L</b>
	<b>EXTENSION Ø600 x 250 mm</b> [code: 7100520630] <b>EXTENSION Ø600 x 500 mm</b> [code: 7100520640]	Extension made of PE material, dimensions Ø600 x 250 mm or Ø600 x 500 mm	<b>RoOki 3.000 L</b> <b>RoOki 5.000 L</b> <b>RoOki 10.000 L</b>
	<b>TELESCOPIC EXTENSION AND COVER WITH HINGED OPENING DN 600</b> [code: 7600088710]	Telescopic extension with cover made of PE material, dimensions Ø600 x 400 mm	<b>Roterra</b> <b>Roterra 2450</b> (all volumes) <b>RoBox 5000</b>
	<b>ADDITIONAL EXTENSION DN 600 x 500</b> [code: 7113110700]	Extension made of PE material, dimensions Ø600 x 500 mm	<b>Roterra</b> <b>Roterra 2450</b> (all volumes)
	<b>THREADED ADAPTER FOR FINE FILTER</b> [code: 7100520320]	Threaded adapter for fine filter made of PE material, dimensions Ø800 x 585 mm	<b>RoBox 5000</b>

## CAST IRON COVERS



	<b>COVER AND FRAME DN 600 (600)</b> [code: 7100520601]	Cast iron cover and frame, load capacity up to 125 kN, dimensions Ø600 mm	<b>Roterra</b> <b>Roterra 2450</b> (all volumes)
	<b>COVER AND FRAME DN 600 (603)</b> [code: 7100520603]	Cast iron cover and frame, load capacity up to 250 kN, dimensions Ø600 mm	<b>Roterra</b> <b>Roterra 2450</b> (all volumes)
	<b>COVER AND FRAME DN 600 (604)</b> [code: 7100520604]	Cast iron cover and frame, load capacity up to 400 kN, dimensions Ø600 mm	<b>Roterra</b> <b>Roterra 2450</b> (all volumes)













IMAGE	NAME AND CODE	DESCRIPTION	SUITABLE FOR
	<b>COVER DN 600, ASSEMBLED</b> [code: 7100520240]	Cover with adapter made of PE material, load capacity up to 2 kN, dimensions Ø690 x 120 mm	<b>RoCko</b> <b>RoVoda</b> <b>RoDrink</b> (all volumes) <b>Sand trap Ø640</b>
	<b>COVER DN 600</b> [code: 7100520190]	Cover made of PE material, load capacity up to 2 kN, dimensions Ø690 x 65 mm	<b>RoCko</b> <b>RoVoda</b> <b>RoDrink</b> (all volumes) <b>Sand trap Ø640</b>
	<b>COVER DN 600 ADAPTER</b> [code: 7100520310]	Adapter for cover DN 600 made of PE material, dimensions Ø690	<b>RoCko</b> <b>RoVoda</b> <b>RoDrink</b> (all volumes) <b>Sand trap Ø640</b>
	<b>COVER DN 800, ASSEMBLED</b> [code: 7100520620]	Cover with adapter made of PE material, load capacity up to 2 kN, dimensions Ø855 x 130 mm	<b>RoCko</b> <b>RoDrink 2450</b> (all volumes)
	<b>COVER DN 800</b> [code: 7100520600]	Cover made of PE material, load capacity up to 2 kN, dimensions Ø855 x 70 mm	<b>RoCko</b> <b>RoDrink 2450</b> (all volumes)
	<b>COVER DN 800 ADAPTER</b> [code: 7100520610]	Adapter for cover DN 800 made of PE material, dimensions Ø800	<b>RoCko</b> <b>RoDrink 2450</b> (all volumes)
	<b>COVER DN 1000, ASSEMBLED</b> [code: 7100520970]	Cover with adapter made of PE material, load capacity up to 2 kN, dimensions Ø1135 x 160 mm	<b>RoCko</b> (all volumes)
	<b>COVER DN 1000</b> [code: 7100520870]	Cover made of PE material, load capacity up to 2 kN, dimensions Ø1135 x 85 mm	<b>RoCko</b> (all volumes)
	<b>COVER DN 1000 ADAPTER</b> [code: 7100520880]	Adapter for cover DN 1000 made of PE material, dimensions Ø1000	<b>RoCko</b> (all volumes)
	<b>COVER DN 800</b> [code: 7100901810]	Cover made of PE material, load capacity up to 6 kN, dimensions Ø800 x 100 mm	<b>RoCko Ø2310</b> (vsi volumni)
	<b>EXTENSION DN 800 x 750 mm</b> [code: 7100067020]	Extension made of PE material, dimensions Ø800 x 750 mm	<b>RoCko Ø2310</b> (vsi volumni)
	<b>ARTIFICIAL GRASS COVER</b> [code: 7100901820]	An artificial grass cover that elegantly covers the PE cover placed on the grassy areas.	







	IMAGE	NAME	CODE	DIMENSIONS
WASHERS		For smooth PVC / PP pipes, for sealing joints, inlets and outlets. They can be used to connect different elements (tanks, filters, sand traps, shafts ...)		
		<b>Rubber washer Ø50 mm</b>	[code: 7112803020]	dimensions Ø50
		<b>Rubber washer Ø110 mm</b>	[code: 7112803040]	dimensions Ø110
		<b>Rubber washer Ø125 mm</b>	[code: 7112803050]	dimensions Ø125
		<b>Rubber washer Ø160 mm</b>	[code: 7112803230]	dimensions Ø160
		<b>Rubber washer Ø200 mm</b>	[code: 7112803060]	dimensions Ø200
		<b>CONNECTORS 1/2" up to 6/4"</b>	[code: 7131440200]	1/2" up to 6/4"

	IMAGE	NAME	CODE	DIMENSIONS
FILTERS		<b>BUILD-IN FILTER SET</b> [code: 7100062480]	Already built-in filter. Components: inflow pipe DN 110, fine filter, calming and overflow siphon (D3).	300 x 150 x 150
		<b>FILTER - SIEVE</b> [code: 7181530010]	Filter - sieve, which is mounted on the neck of the tank and allows the filtration of larger particles (leaves, branches ...)	Ø400 x 200
		<b>SANITARY WATER FILTER ON THE DISTRIBUTION NETWORK</b> [code: 7100065490]	Combined water filtration system for complete purification of water used in the household. It thoroughly cleans mechanical particles, chlorine and removes any bad smell or taste from the water. If necessary, a UV disinfection device can be installed behind the filter.	/
		<b>DRINKING WATER FILTER ON THE DISTRIBUTION NETWORK</b> [code: 7100092810]	A domestic water station that provides well-purified and microbiologically safe drinking water. Water filtration and UV disinfection system.	/













RAIN GUTTER SHAFTS		<b>GUTTER MANHOLE (SEWER) L</b> [code: 7100070950]	The duct is the link between the gutter and the inlet pipes to the tank. Adjust the lid according to the shape and size of the spout. Outflow DN 110, 125, 160.	Ø250 x 600
		<b>GUTTER MANHOLE (SEWER) I</b> [code: 7100520080]	The duct is the link between the gutter and the inlet pipes to the tank. Outflow DN 110, 125, 160.	Ø250 x 420

	IMAGE	NAME	CODE	DIMENSIONS
SAND TRAPS		The sand and leaves from the roof are separated from the water in the sand trap. The inlet / outlet washers are DN 110 and DN 125. There are two versions available with or without a carbon filter and mesh.		
		SAND TRAP Ø400 x 1000	[code: 7100066373]	Ø400 x 1000
		SAND TRAP Ø400 x 1500	[code: 7100066353]	Ø400 x 1500
		SAND TRAP Ø500 x 1000	[code: 7600059520]	Ø500 x 1000
		SAND TRAP Ø500 x 1500	[code: 7600059540]	Ø500 x 1500
		SAND TRAP Ø640 x 1000	[code: 7600074450]	Ø640 x 1000
		SAND TRAP Ø640 x 1500	[code: 7600074470]	Ø640 x 1500
GULLIES		ROAD GULLIE Ø400 x 800	[code: 7100076480]	Ø400 x 800
		ROAD GULLIE Ø400 x 1300	[code: 7100076490]	Ø400 x 1300
WITH FILTER		SAND TRAP WITH FILTER Ø400 x 800 IN POKROVOM	[code: 7100065970]	Ø400 x 800
		SAND TRAP WITH FILTER Ø640 x 800 IN POKROVOM	[code: 7100074500]	Ø640 x 800
	IMAGE	NAME	CODE / DESCRIPTION	DIMENSIONS
LEVEL GAUGES		<b>WATER LEVEL GAUGE - BASIC</b> Manufacturer: Apolo [code: 7100065560]	Remote wireless water level display. Reach up to 300 m. Easy installation and battery powered.	/
		<b>WATER LEVEL GAUGE - PROFI</b> Manufacturer: Navis [code: 8001230]	Remote wireless water level display. Reach up to 300 m. Easy installation and battery powered.	/
FINE FILTERS		<b>FINE FILTER Ø400 x 430 mm FOR UP TO 400 m² ROOF AREA</b> [code: 7100092800]	It allows efficient cleaning of water flowing from the roof. Inflow 2x DN 110, outflow DN 110 and DN 125.	Ø400 x 450
		<b>FINE FILTER DUO FOR UP TO 700 m² ROOF AREA</b> [code: 7100066180]	It allows efficient cleaning of water flowing from the roof. Inflow je 2x DN 100 / DN 150, outflow 2x DN 100 / DN 150.	873 x 680
		<b>EXTENSION FOR FINE FILTER Ø400</b> [code: 0009282]	Extension for fine filter Ø400.	/
RINGS		<b>REINFORCEMENT RING FOR TANK - PAINTED (KIT)</b>	[code: 71210279]	Ø2350 x 100
		<b>REINFORCEMENT RING FOR TANK - GALVANIZED (KIT)</b>	[code: 7112102790]	Ø2350 x 100

## Installation instructions for **Roto water tanks**

When digging the tank in, the instructions must be followed. In cases where simple self-installation is not possible, please consult the manufacturer or relevant experts. Avalanches, floods and other difficult terrain require the advice of an experienced professional. We also offer advice and a presence at the time of installation to ensure correct and quality installation.



### 1. TRANSPORT OF THE TANK

The tank must be on a level surface during transport. Care must be taken to avoid any sharp edges that could damage the tank. The tank should be secured to the means of transport with polyester or similar straps. Care must be taken to ensure that the belts are not too tight.



### 2. HANDLING THE TANK ON SITE

The tank is lifted and carried using lifting straps. Attach the lifting straps to the tank clamps or to the marked positions. The tank should be moved using suitable construction equipment, taking care to avoid damage to the tank. The tank must not be rolled or dragged.



### 3. TEMPORARY STORAGE

The tank must be stored on a suitable, level and smooth surface. You should be aware of any sharp objects on the ground that could cause damage to the tank. If the tank is damaged before installation, this must be reported immediately to the manufacturer. Repairs should be carried out in accordance with the manufacturer's written instructions.



### 4. BEFORE INSTALLATION or BUILDING IN

Before installing the tank, the composition and properties of the soil must be carefully checked. The floor of the construction pit must be hardened and stable. In case of poor bearing capacity of the ground, a cushion with gravel material 40 cm thick or concrete must be constructed. The cushion must be consolidated to a minimum compaction of 60 MPa. Excavated material must be removed from the excavation pit so that it does not mix with the backfill material.



### 5. EXCAVATION DIMENSIONS

The floor area of the construction pit should be 60–100 cm larger than the floor area of the tank. The tank must be a minimum of 150 cm from the building and a minimum of 200 cm from the carriageway. If the type of terrain permits, dig a construction pit with walls as vertical as possible (the embankment angle of the soil and safe working measures must be taken into account). All applicable safety and building regulations must be observed during installation. The depth of the excavation must be coordinated with the design and dimensions of the tank.



### 6. BACKFILL MATERIAL

The material used to fill the tank must be of the correct granulation. The material must be washed free of ice or snow, clay, particles of coarse granulation and other organic particles. Suitable material is sandy gravel or crushed stone with a granular size of 4–16 mm.

Backfilling and compaction of the backfill material should be carried out in phases or in 300 mm thick layers. The tank must be filled with water at the same time, so that the level of backfill material and water in the tank is the same at all times. This gives the same lateral pressure on the tank wall. Each layer must be well consolidated with lightweight compaction machines. When backfilling, the elevation and cover must be placed on the tank.



### 7. ANCHORING THE TANK

Anchor lugs (20 mm diameter stainless steel rod) must be installed in the base plate. A rope or cable made of stainless steel and resistant material should be attached to the anchor lugs using wire clips. The rope or wire rope is tensioned using a tension nut. All fixing materials should be made of stainless steel. To prevent direct pressure of the rope on the container, place a geotextile (approx. 100 mm wide) between the surface of the tank and the rope. On the tank on which the clamps are installed, the anchoring should be executed at the clamp lugs. Polyester straps can also be used instead of stainless steel ropes.



### 8. AB BASE PLATE

The reinforced concrete base slab should be placed on a hardened base. The minimum thickness of the AB foundation slab is 200 mm (sizing to be carried out by a structural engineer). It should be reinforced with two reinforcing nets. The base plate should be 600 mm wider than the floor dimensions of the tank.



### 9. TRAFFIC LOAD

The traffic load must not be transferred directly to the tank. Therefore, an AB relief slab must be constructed above the tank. The AB slab is dimensioned by a structural engineer according to the load and the AB slab must be properly supported. In case of traffic loads, an LTŽ cover must be installed on the tank.



### 10. PHOTODOCUMENTATION OF INSTALLATION

In order to claim the against the warranty in case of damage to the tank, the entire installation must be photo-documented. The manufacturer shall not be held liable for any damage to the tank caused during the digging process in case of incorrect installation of the tank.

## Easy installation – **WALKING AREA**

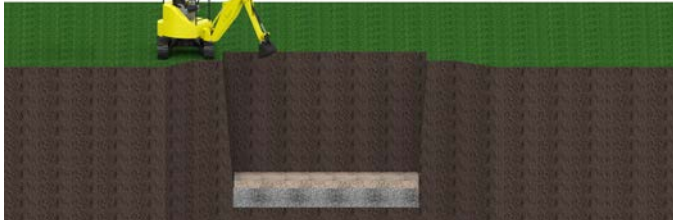

### 1. PHASE - Pit preparation

The floor area of the construction pit must be 60–100 cm larger than the floor area of the tank. If the type of terrain permits, dig a construction pit with walls as vertical as possible (the embankment angle of the soil and safe working measures must be taken into account).

The planum of the construction pit must be level and consolidated. If the soil is less load-bearing, a rehabilitation cushion with gravel material 40 cm thick or lean concrete is required. The rehabilitation cushion must be consolidated to a minimum compaction of 60 MPa

A sand bed at least 15 cm thick shall be laid on the prepared sub-base. Sand with a granulation of 0–4 mm is placed in the construction pit and levelled.



### 2. PHASE – installation in the pit

Carefully place the tank on a level sand bed (lifted by a suitable mobile lifting or working machine) and level it using a water balance.

Adjust the tank extensions (inspection openings) to the final ground level.

The telescopic extension adjusts to the final terrain by tightening and loosening. The integrated extension is adjusted by removing the adapter with the cover and cutting the neck to the appropriate final ground level.

It is important that the extension and the cover are placed on the tank when backfilling.

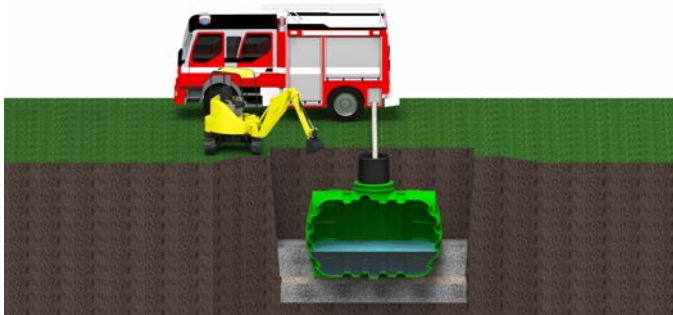

### 3. PHASE – backfill

Backfill the tank up to 30 cm measured from the bottom of the tank with 4–16 mm fraction and simultaneously fill it with water up to 30 cm measured from the bottom of the tank (fill all compartments).

Care must be taken to ensure that the fraction is well fed under the rounded parts of the tank. The filling of the tank with water and backfilling with fraction is repeated in 30 cm increments until the tank is backfilled to the first connection.

When backfilling the tank, we need to pay attention to the level of the connections (inlet, outlet, etc.) to ensure that they are made in time.



### 4. PHASE – Final embankment

Once the connections have been properly connected and are watertight, the pit is backfilled with fraction up to the last 25 cm.

Place geotextile over the backfill with 4–16 mm fraction – over the entire tank area.

The last 25 cm of backfill is made with the soil excavated when digging the construction pit. Care must be taken not to fill the tank lid.

The maximum height of the embankment above the top of the tank is 80 cm.

In case of impermeable terrain, drainage around the tank is mandatory.

## UNDERGROUND WATER

The floor area of the construction pit must be 60–100 cm larger than the floor area of the tank. If the type of terrain permits, dig a construction pit with walls as vertical as possible (take into account the angle of the soil and safe working measures).

The planum of the construction pit must be level and consolidated. If the soil is less load-bearing, a rehabilitation cushion with 30–40 cm thick gravel material or concrete is required. The rehabilitation cushion must be consolidated to a minimum compaction of 60 MPa.

A reinforced concrete floor slab with a thickness of approx. 20 cm with inset reinforcement grid. The floor slab must be 60 cm wider than the dimensions of the tank (dimensioning of the AB floor slab to be carried out by a structural engineer). Stainless steel anchors are inserted into the floor slab (anchoring procedure described in point 7).

The tank is carefully placed on a prepared concrete slab (installed with a suitable mobile lift truck or excavator) and levelled using a water balance. The telescopic threaded extension is adjusted to the final ground level. The tank is secured to the anchors using 12 mm steel braided rope. All fixing materials must be made of stainless steel (anchoring described in point 7).

A drainage pipe with a diameter of fi 110 is installed around the tank and fed into the sump with the pump. Particular attention should be paid to the backfill under the curved parts of the tank. At the same time, the tank must be filled with water (all chambers). The filling of the tank with water and backfilling with gravel fraction 4–16 mm is repeated in 30 cm increments – up to the maximum groundwater level. Above the maximum level and up to the last 25 cm, the tank is backfilled with a gravel fraction of 4–16 mm. We need to pay attention to the connection levels so that we can make them in time.

During installation, the connection of the tank (inlet, outlet) is executed. Continue backfilling up to the last 25 cm.

Place geotextile (200 g/m<sup>2</sup>) over the backfill with 4–16 mm fraction – over the entire area of the tank.

The last 25 cm of the backfill is backfilled with soil (200 g/m<sup>2</sup> geotextile is applied before backfilling). Care must be taken not to fill the tank lid.

The maximum height of the embankment above the tank is 80 cm.

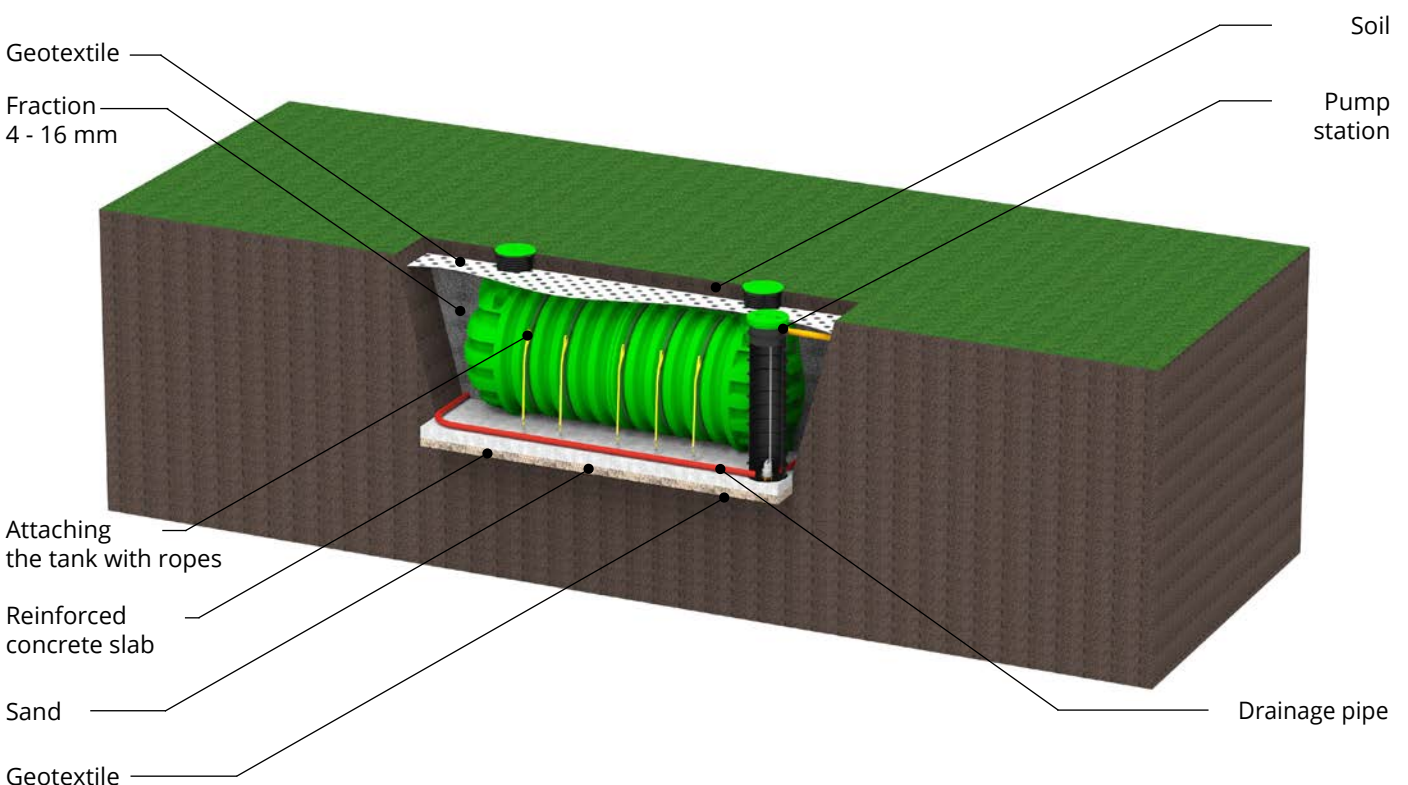

## ROAD SURFACES

The floor area of the construction pit must be 60–100 cm larger than the floor area of the tank. If the type of terrain permits, dig a construction pit with walls as vertical as possible (take into account the angle of the soil and safe working measures).

The planum of the construction pit must be level and consolidated. If the soil is less load-bearing, a rehabilitation cushion with 30–40 cm thick gravel material or concrete is required. The rehabilitation cushion must be consolidated to a minimum compaction of 60 MPa.

A sand bed at least 15 cm thick shall be laid on the prepared sub-base. Sand with a granulation of 0–4 mm is placed in the construction pit and levelled.

The tank is carefully placed on a sand bed (installed with a suitable mobile lift truck or excavator) and levelled using a water balance. The telescopic threaded extension can be adjusted to the desired level.

Backfill the tank up to 30 cm measured from the bottom of the tank with 4–16 mm fraction and simultaneously fill it with water up to 30 cm measured from the bottom of the tank (fill all compartments). Care must be taken to ensure that the fraction is well fed under the rounded parts of the tank. The filling of the tank with water and backfilling with fraction is repeated in 30 cm increments until the tank is backfilled to the level of the connections.

Make the connections to the tank (inlets, outlets, etc.). Backfill the rest of the construction pit up to the last 25 cm with 4–16 mm fraction.

The fraction is relieved by an AB slab with a thickness of approx. 20 cm with embedded reinforcing mesh (sizing of the slab to be carried out by a structural engineer according to the load). The edge of the AB slab shall extend at least 1 metre laterally from the construction pit.

Install an cast iron cover over the inlet.

The maximum height of the embankment above the tank is 80 cm.

In the case of impermeable terrain, drainage around the tank must be carried out in the same way as in the case of a groundwater trench.

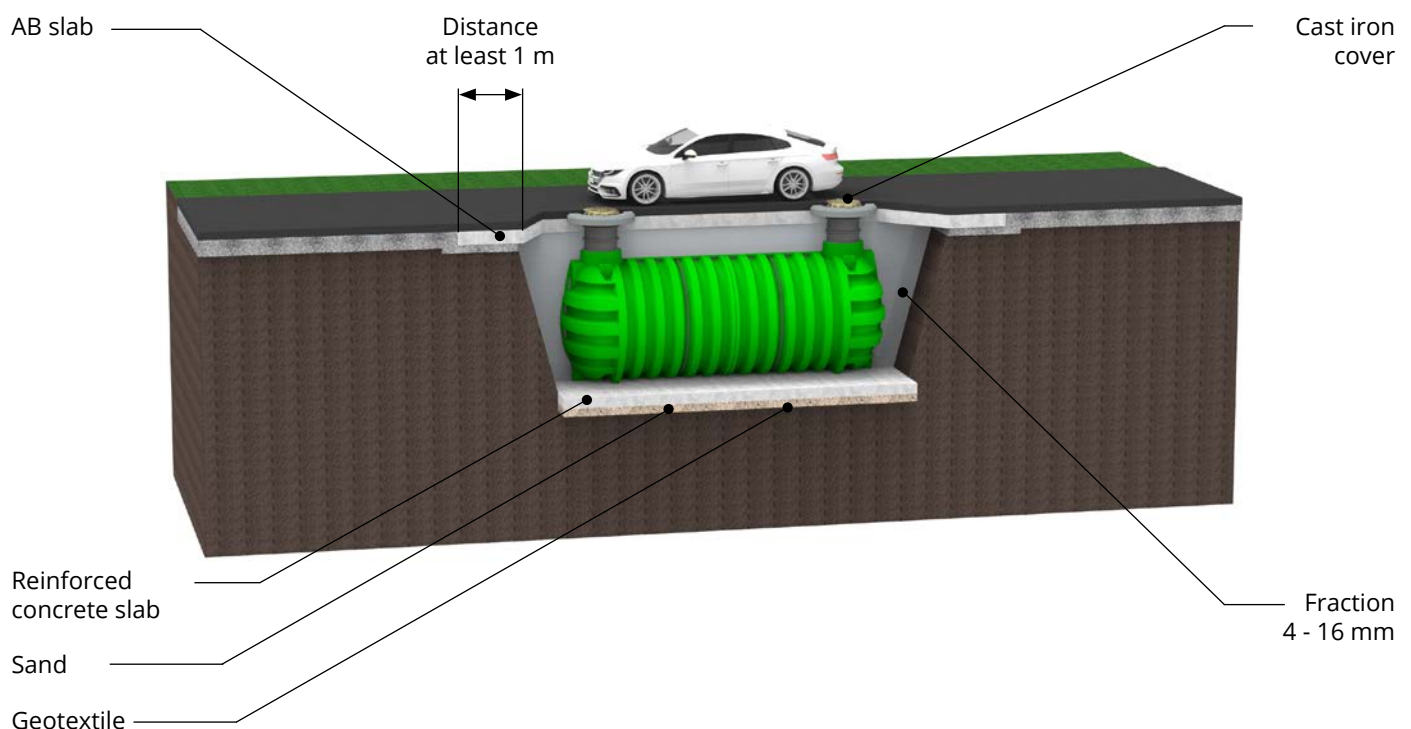

## DEEP INSTALLATION

The floor area of the construction pit must be 60–100 cm larger than the floor area of the tank. If the type of terrain permits, dig a construction pit with walls as vertical as possible (take into account the angle of the soil and safe working measures).

The planum of the construction pit must be level and consolidated. If the soil is less load-bearing, a rehabilitation cushion with 30–40 cm thick gravel material or concrete is required. The rehabilitation cushion must be consolidated to a minimum compaction of 60 MPa.

A 15 cm thick sand bed (0–4 mm granularity) is placed on the prepared sub-base. The bed must be properly aligned.

The tank is carefully placed on the sand bed (installed with a suitable mobile lift truck or excavator) and levelled using a water balance. The telescopic threaded extension can be adjusted to the desired level. If there is an integrated extension above the tank, cut it off and reposition the adapter with the cover.

Backfill the tank up to 30 cm measured from the bottom of the tank with 4–16 mm fraction and simultaneously fill it with water up to 30 cm measured from the bottom of the tank (fill all compartments). Care must be taken to ensure that the fraction is well fed under the rounded parts of the tank. The filling of the tank with water and backfilling with fraction is repeated in 30 cm increments up to the level of the connections. When backfilling, pay attention to the connections to ensure that they are made in time.

Make the connections to the tank (inlets, outlets, etc.). After the connections have been made, backfill the construction pit up to the last 25 cm of the overhang.

The fraction is relieved by an AB slab with a thickness of approx. 20 cm with embedded reinforcing mesh (sizing of the slab to be carried out by a structural engineer according to the load). The edge of the AB slab should extend at least 1 metre laterally from the construction pit.

A PE access shaft with a clear opening of at least 100 cm should be installed above the AB relief slab. The height of the shaft should be adjusted to the final ground level. At greater depths, it is obligatory to provide an access stair or ladder.

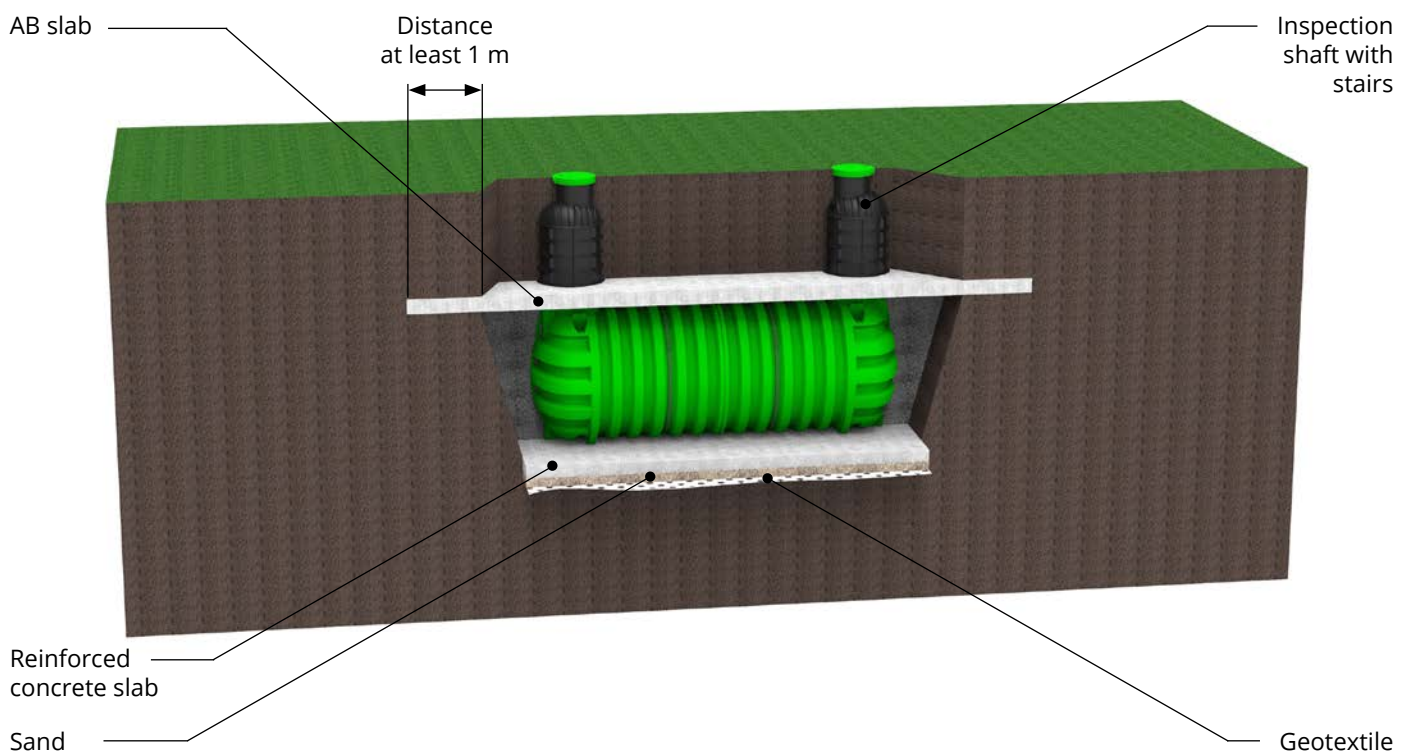

# Certificates



# INTELLIGENT **eco** SOLUTIONS

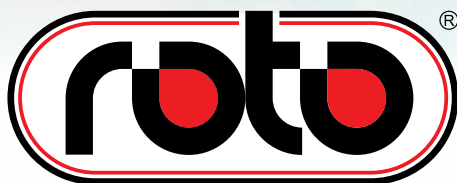
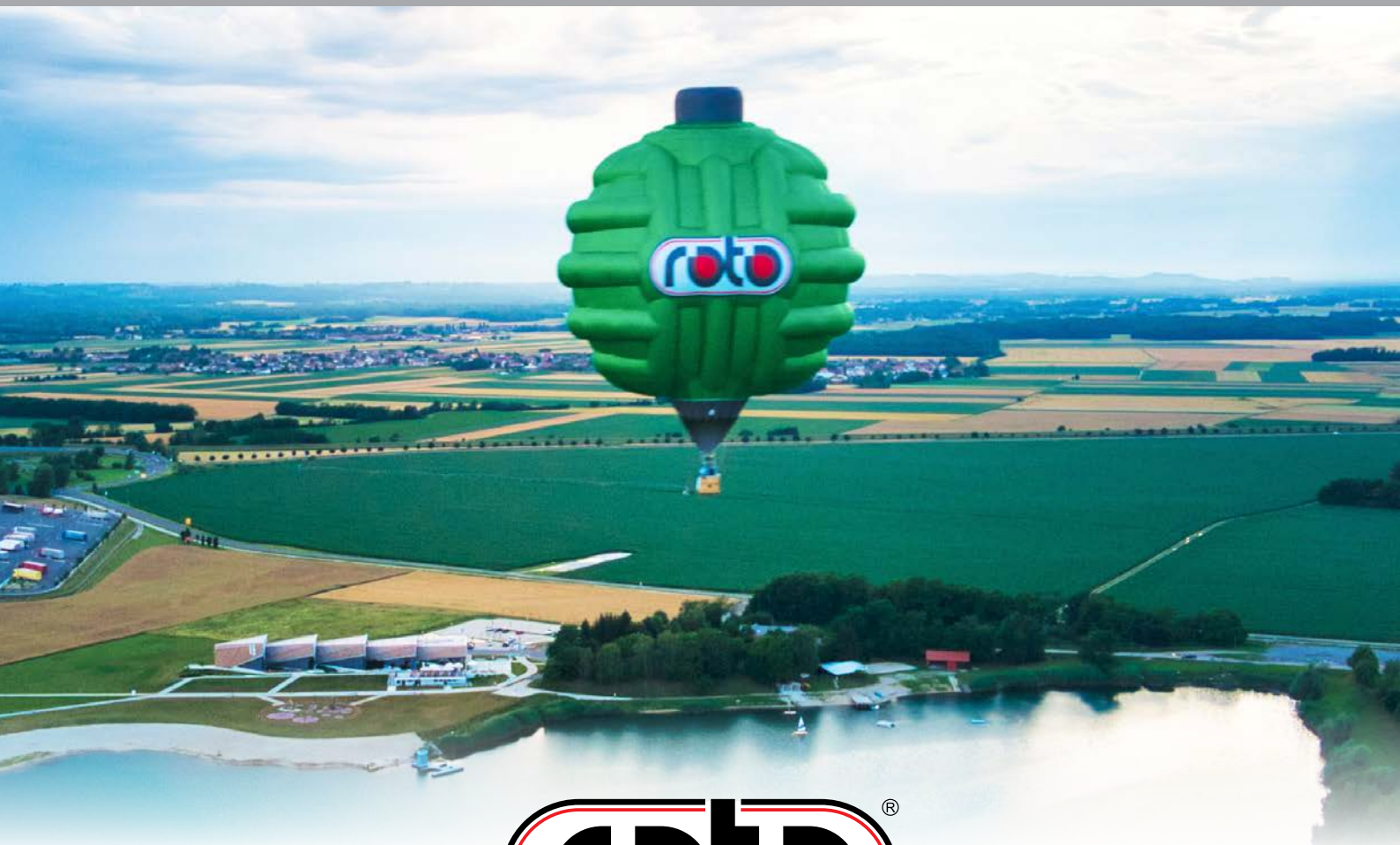

## **THE LEADING COMPANY IN THE INDUSTRY**

More than 40 years of experience in the production of plastic products and solutions for ecology  
Roto exports its products to 55 countries worldwide



## **DEVELOPMENT OF NEW PRODUCTS**

Roto masters the entire development process from design, prototyping, tool making and production  
We develop 3 new products every week



## **THE LARGEST PLASTIC PRODUCTS**

The ROTO Group has production in 4 European countries, in 7 factories  
One of the largest machines in the world for the production of water tanks is in Slovenia



## **WIDE RANGE OF PRODUCTS**

Roto technological solutions are intended for ecology, construction, gardening, agriculture and industry  
Roto manufactures over 4000 different products



## **EXCELLENT QUALITY**

we provide excellent quality and efficiency of ROTO products, professional  
and technical support and maintenance  
In accordance with ISO 9001 and ISO 14001 standards



CATALOG VERSION: 4 / 2021

[www.rotoECO.eu](http://www.rotoECO.eu)